

F-1500 Insertion Turbine Meter

Installation Hardware Instructions



For Welded Steel Pipe (Suitable for Water Applications Only)

For Use with Kits: INSTL200S-FMH

Note: Please read entire manual before installing the flow meter

This kit can be installed during a system shutdown or on a pressurized pipe. Once installed, this kit allows for insertion and removal of the flow meter without a system shutdown. For installations on a pressurized pipe, a hot tap drilling machine is used to create a 2" opening in the pipe wall.

IMPORTANT NOTE

ONICON insertion flow meters are precision measuring devices that must be installed according to the instructions contained in this document in order to maintain their accuracy and reliability. Failure to follow these instructions will result in erratic operation and reduced accuracy.

Directions for installation during system shutdown

1. Identify an appropriate location for the flow meter.
2. Turn off the flow and verify that the line is not pressurized.
3. Use a cutting torch or sharp cutting tool to tap into the pipe. The pipe opening must be at least 1.875" in diameter.
4. Remove all burrs and rough edges from the hole. Rough edges may affect flow meter accuracy or damage the sensor assembly when inserting the meter into the pipe.
5. After cutting, measure the thickness of the cut-out and record this number for calculating the insertion depth when installing the flow meter.
6. Weld the threaded branch outlet onto the pipe. Make sure this connection is within $\pm 5^\circ$ of being perpendicular to the pipe centerline.
7. Install the close nipples, gate valve and pipe coupling as shown in the drawing on the next page using the appropriate paste type thread sealant or Teflon[®] tape as needed.
8. Flush, pressurize and leak test the system.

Directions for installation in a pressurized system

1. Identify an appropriate location for the flow meter.
2. Weld the 2" threaded branch outlet on the pipe making sure the outlet is within $\pm 5^\circ$ of being perpendicular to the pipe centerline.
3. Install the close nipples, gate valve and pipe coupling as shown in the drawing on the next page using the appropriate paste type thread sealant or Teflon[®] tape as needed.
4. Run a static pressure check on the assembly. If pressure loss or leaks are detected, repair and re-test.
5. Use a hot tap drilling machine to create the access hole in the pipe. The access hole must be at least 1.875" in diameter.
6. Retract the drill, close the isolation valve, and remove the hot tapping equipment.
7. Measure the thickness of the cut-out and record this number for calculating the insertion depth when installing the flow meter.

F-1500 Insertion Turbine Meter

Installation Hardware Instructions

Installation Kit Components

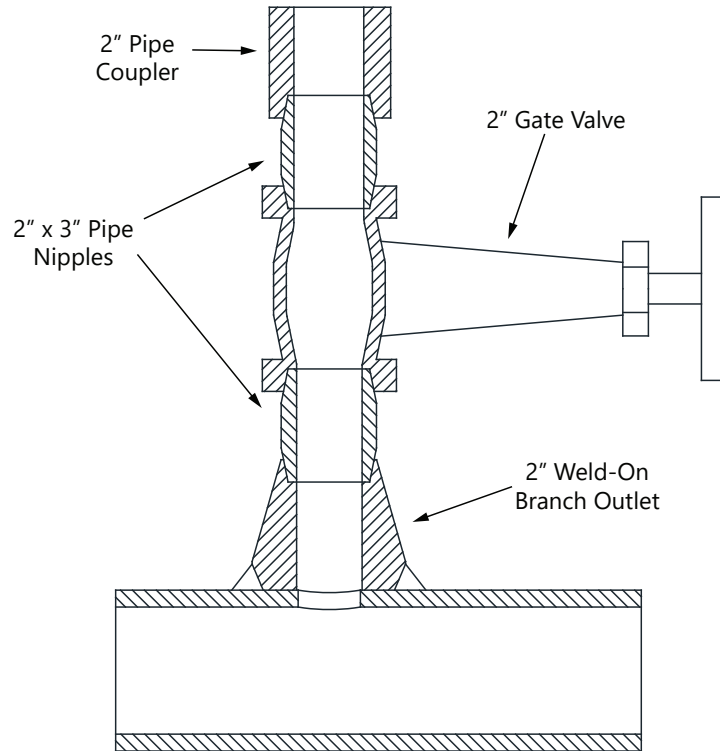

Evaluating Upstream Piping Conditions

- Better**
 ↑
 ↓
Worse
- Straight Pipe**
 - Single Bend**
 - Pipe Reduction or Enlargement**
 - Outflowing Tees**
 - Multiple Bends in Same Plane**
 - Multiple Bends Out of Plane**
 - Inflowing Tees**

How to determine the available straight pipe diameters:

For each application, locate the longest straight, unobstructed section of pipe (no bends, tees, valves, other insertion probes, size transitions, etc.). The longest straight pipe run in inches divided by nominal pipe size in inches equals "diameters of straight pipe." For closed loop applications, consider both the supply and return lines as possible locations.

F-1500 Insertion Turbine Meter

Installation Hardware Instructions

Unobstructed Flow Requirements

Select an installation site that will minimize possible distortion in the flow profile. Valves, elbows, control valves and other piping components may cause flow disturbances. Check your specific piping condition against the examples shown below. In order to achieve accurate and repeatable performance, install the flow meter using at least the recommended number of straight run pipe diameters upstream and downstream of the sensor. Details shown on next page.

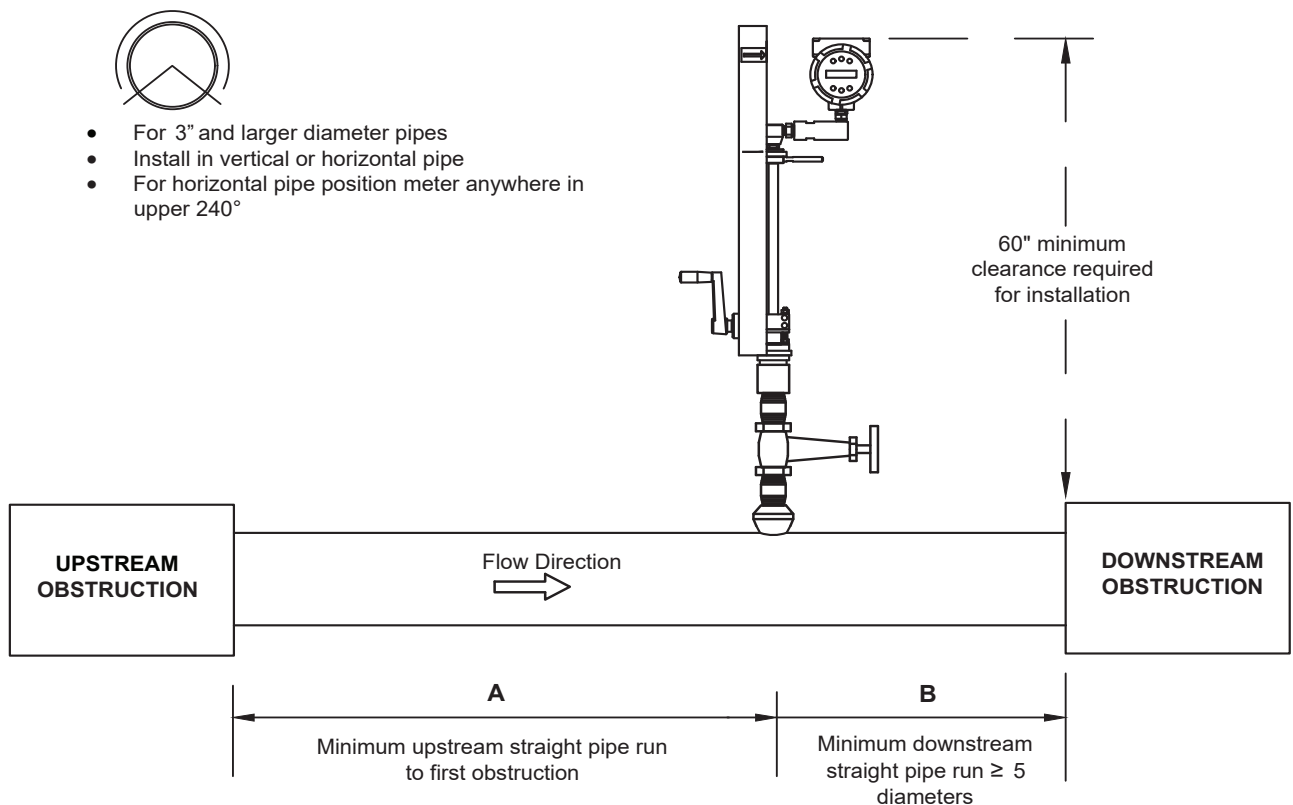

NOTE: For liquid applications in vertical pipes, avoid installing with flow in the downward direction because the pipe may not be full at all points. Choose to install the meter with flow in the upward direction, if possible.

F-1500 Insertion Turbine Meter

Installation Hardware Instructions



Recommended Pipe Length Requirements for Installation

Example	Minimum Required Upstream Diameters	Minimum Required Downstream Diameters
	A	B
Single (90°) elbow	10D	5D
Two (90°) elbows in one plane	15D	5D
Two (90°) elbows out of plane*	30D	10D
Reduction before meter	10D	5D
Regulator or valve partially closed **	30D	10D
D = Internal diameter of channel		
Notes		
* If three 90° bends present, double recommended length		
** If valve is always fully open, base length requirements on fitting directly preceding it		

Always use the maximum available straight run. When more than the minimum required straight run is available, place the meter such that the excess straight run is upstream of the meter's location.