

SYSTEM-1000 SUBMITTAL AND DATA SHEET



TO:

DATE:

REVISION:

PROJECT NAME:

CONTRACTOR:

ENGINEER:

ONICON REP:

SUBMITTAL FOR:

- RECORD
- APPROVAL

APPROVED BY:

RELEASED FOR:

- MANUFACTURING AND SHIPMENT
- HOLD FOR RELEASE
- APPROVED
- APPROVED AS NOTED
- DISAPPROVED

EXPLANATION:

PLEASE RETURN APPROVED DRAWINGS TO:

ATTENTION:

SUBMITTED BY:



DESCRIPTION

The System-1000 Flow and Energy Measurement System is a BTU Meter with up to four channels that provides highly accurate thermal energy measurement in chilled water, heating hot water, condenser water, and domestic water systems. Energy measurement is based on signal inputs from matched precision temperature sensors and any of ONICON's inline, insertion, or clamp-on style flow meters.

The System-1000 can perform up to four thermal energy calculations simultaneously, and it allows for the addition or subtraction of two flow rates to solve challenging flow measurement locations.

The System-1000 utilizes calculated thermal energy data and uses electrical, steam, gas, or thermal energy data via analog input to calculate the real-time coefficient of performance (COP) for various types of hydronic systems.

The flexible design provides energy, flow, temperature, and efficiency data on the local display via BACnet MS/TP or IP, MODBUS RTU or TCP/IP, and via analog and pulse outputs. Auxiliary pulse and analog inputs are also available to allow other devices to provide rate and total data to the serial network.

APPLICATIONS

The System-1000 is ideal to measure up to four applications simultaneously. Typical applications include a combination of chilled water, heating hot water, or condenser water systems for:

- Chilled water and heating hot water systems
- Total chiller performance and efficiency
- University campus monitoring
- Central plant monitoring
- Domestic water including recirculation lost
- Thermal/Ice storage systems
- Lake, solar, geothermal, ground sourcing energy monitoring
- Performance contracting energy monitoring
- Commercial office tenant billing
- Institutional energy cost allocation
- Glycol/Water or other mixtures loops

SYSTEM-1000 SUBMITTAL AND DATA SHEET



GENERAL SPECIFICATIONS*

SYSTEM-1000 TRANSMITTER			
PERFORMANCE	CALCULATOR ACCURACY	Computing nonlinearity within $\pm 0.05\%$	
	TEMPERATURE ACCURACY / AVAILABLE OPTIONS	Precision solid state current based sensors. Signal (mA) is unaffected by wire length. Overall differential temperature measurement uncertainty of $\pm 0.15^\circ\text{F}$ over the application range. Liquid temperature range: 32°F to 200°F	
		1000 Ω platinum RTDs calibrated to a differential measurement uncertainty of $\pm 0.18^\circ\text{F}$ over the stated range	
FLOW RATE	See accuracy statement provided with the flow meter (ordered separately)		
MECHANICAL	DIMENSIONS	13.96" W x 12" H x 6.04" D	
MATERIALS	ENCLOSURE	ADC12 Die Cast Aluminum	
ENVIRONMENTAL	OPERATING TEMPERATURE RANGE	-13°F to 140°F	
	ENCLOSURE RATING	NEMA 13	
POWER SUPPLY REQUIREMENTS	24 VAC/DC	22 - 28 V DC/AC, 50/60Hz, 100VA	
	120-240 VAC	99 - 126 VAC or 196 - 253 VAC, 50/60Hz, 200VA	
I/O SIGNALS	ONE CHANNEL CONFIGURATION	Frequency Inputs	Two (2) Active Frequency Inputs
		Analog Inputs	Two (2) Active Analog Inputs
		Digital Inputs	Two (2) Open Collector / Isolated Dry Contact for totalization or alarm
		Temperature Sensor Inputs	Two (2) Passive Analog Inputs or Two (2) 1000 Ω RTD Inputs
		Analog Outputs	Four (4) Active Analog Outputs
		Digital Outputs	Four (4) Isolated Dry Contact Inputs for Totalization or Alarm
	TWO AND FOUR CHANNEL CONFIGURATION	Frequency Inputs	Four (4) Active Frequency Inputs
		Analog Inputs	Four (4) Active Analog Inputs
		Digital Inputs	Four (4) Open Collector / Isolated Dry Contact for totalization or alarm
		Temperture Sensor Inputs	Four (4) Passive Analog Inputs or (4) 1000 Ω RTD Inputs
		Analog Outputs	Eight (8) Active Analog Outputs
		Digital Outputs	Eight (8) Isolated Dry Contact Inputs for Totalization or Alarm
NETWORK CONNECTIONS	Isolated RS485 serial interface or IP ethernet port connection		
COMMUNICATION PROTOCOLS	BACnet MS/TP, BACnet UDP/IP, MODBUS RTU, MODBUS TCP/IP		

* SPECIFICATIONS subject to change without notice.

** Installation hardware are provided separately.

GENERAL SPECIFICATIONS* (CONTINUED)

SYSTEM-1000 TRANSMITTER (CONTINUED)			
NETWORK CONFIGURATION & ADDRESSING	BACnet MS/TP	BAUD RATES	9600, 19200, 38400, 57600, or 76800 (Default: 38400)
		DEVICE ADDRESS RANGE	1 – 127 (Default: 017)
		DEVICE INSTANCE RANGE	1 – 4,194,302 (Default: 57017)
		Max Master	1-127
	BACnet/IP	IPV4 Address	Programable (Default: 192.168.1.24)
		Instance Number	1 – 4,194,302 (Default:57017)
		Subnet Mask	Programmable (Default:255.255.255.0)
		Gateway Address	Programmable
		UDP port:	Programmable (Default:47808)
		DHCP	Available
	MODBUS RTU	Address Range	1 - 247 (Default: 017)
		Baud Rate	9600, 19200, 38400, 57600, or 76800 (Default: 19200)
		Data Format	8 Bit (Stop Bits: 1)
		Parity	Even, Odd, None (Default: Even)
		Byte Order	ABCD
	MODBUS TCP/IP	IPV4 Address	Programmable (Default: 192.168.1.24)
		Subnet Mask	Programmable (Default: 255.255.255.0)
		Gateway Address	Programmable
		Port	Programmable (Default: 502)
DHCP		Available	
APPROVALS	FCC	Part 15, Subpart B	
	UL	UL 61010	
	CE		

* SPECIFICATIONS subject to change without notice.

METER ORDERING INFORMATION

Model SYSTEM-1X00-ABC

--	--	--	--

X = System Configuration
1 = Single Channel System
2 = Dual Channel System
4 = Four Channel System

A = Electronics Enclosure
1 = NEMA 13 enclosure with LCD display

B = Input Power
1 = 24 VAC/DC, 100 VA
2 = 120/230 VAC, 200 VA

C = Network Communications
0 = No communications
1 = RS-485 & IP Communications, BACnet, MODBUS

CLICK HERE
[ONICON Order Form](#)
[Application and Ordering Guide](#)

TYPICAL ONE or TWO CHANNEL INSTALLATION

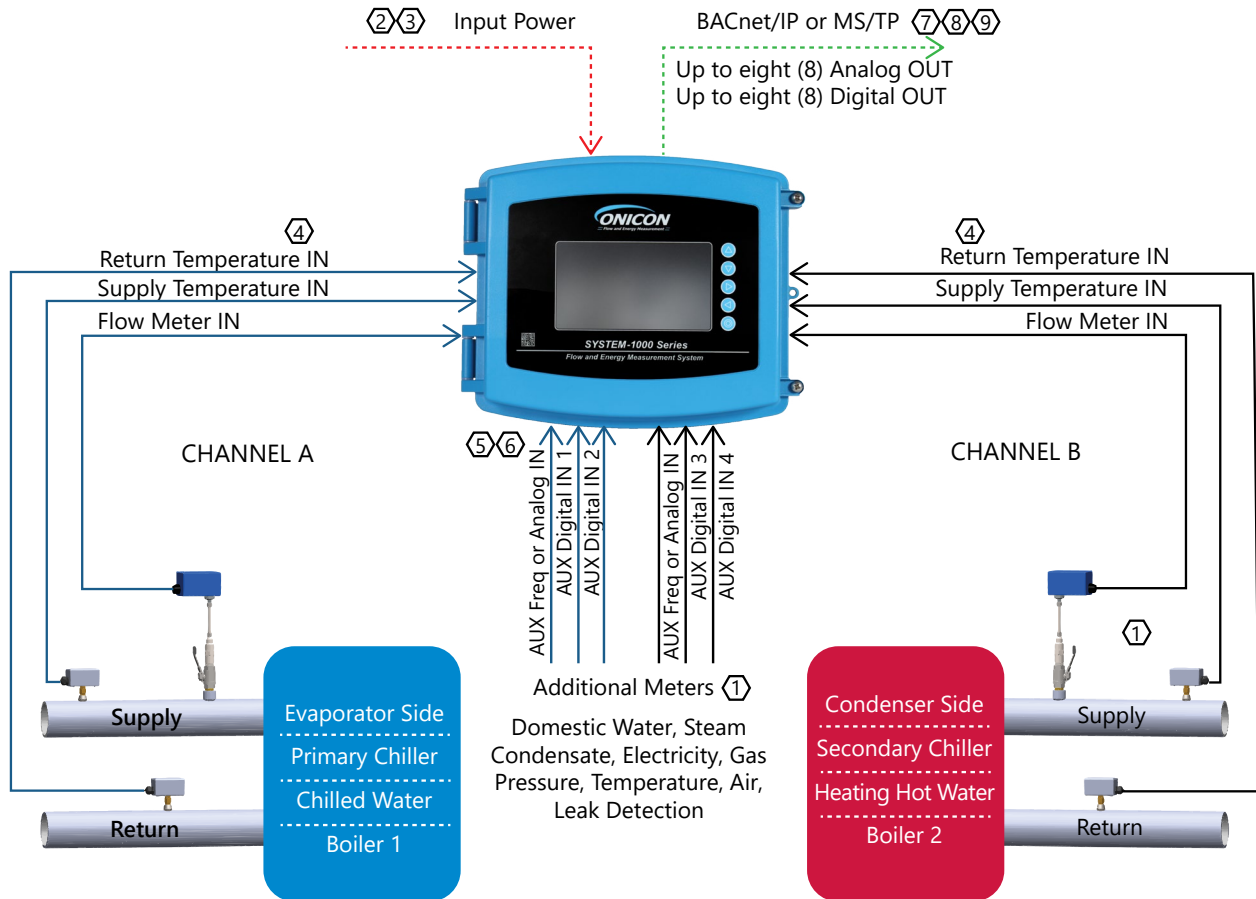

1. ONICON Flow Meters and Temperature Sensors are provided separately
2. Provide a Power supply 24VAC/DC, 100VA Class II or 120/230 VAC 50/60 Hz, 200VA
3. Provide sufficient power supply when the combined current of all devices connected to the SYS-1000 exceeds 1 Amp
4. Flow Meter and Temperature sensors used for thermal energy calculations
5. Auxiliary Digital Inputs are available for close contact alarm signals and totalization
6. Auxiliary Digital Inputs designed for Dry or Wet Contact and Open Collectors
7. Digital Outputs are available for Energy Totals, Flow Totals, Operating Modes, and Alarms
8. Analog outputs are available for Energy Rate, Flow Rate, Supply Temp, Return Temp, Efficiency, and Aux Inputs
9. BACnet® IP or MS/TP OR MODBUS RTU or TCP/IP

TYPICAL FOUR CHANNEL INSTALLATION

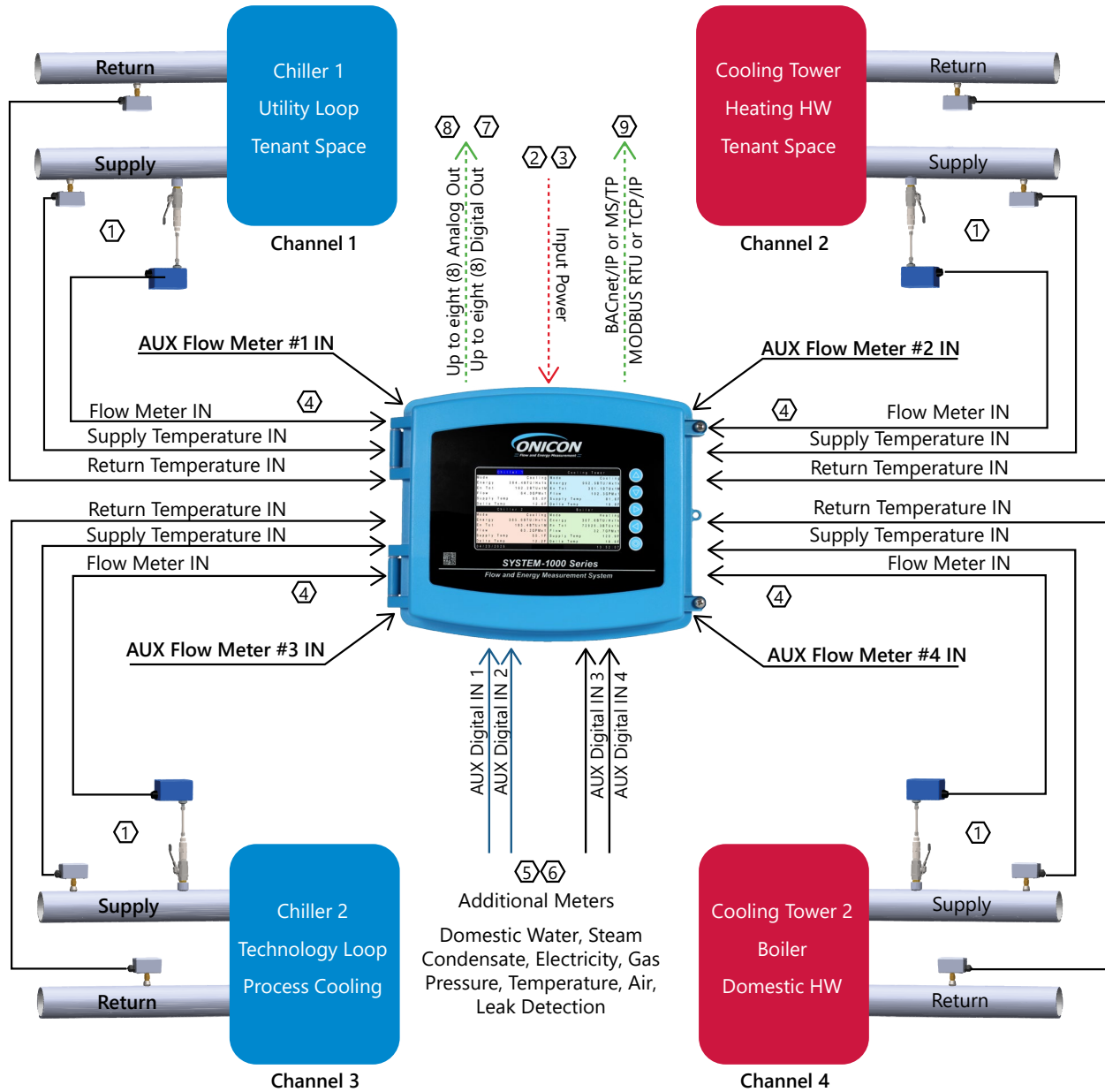

1. ONICON Flow Meters and Temperature Sensors are provided separately
2. Provide a Power supply 24VAC/DC, 100VA Class II or 120/230 VAC 50/60 Hz, 200VA
3. Provide sufficient power supply when the combined current of all devices connected to the SYS-1000 exceeds 1 Amp
4. Flow Meter and Temperature sensors used for thermal energy calculations
5. Auxiliary Digital Inputs are available for close contact alarm signals and totalization
6. Auxiliary Digital Inputs designed for Dry or Wet Contact and Open Collectors
7. Digital Outputs are available for Energy Totals, Flow Totals, Operating Modes, and Alarms
8. Analog outputs are available for Energy Rate, Flow Rate, Supply Temp, Return Temp, Efficiency, and Aux Inputs
9. BACnet® IP or MS/TP OR MODBUS RTU or TCP/IP

THERMOWELLS INSTALLATION SCHEMATICS

A. Overview

ONICON offers four different types of temperature sensor pairs and the associated thermowells for use with the System-1000.

CAUTION

Temperature sensor thermowells must match the sensor diameter. Using the wrong diameter hardware will result in significant temperature measurement errors.

Sensor Type	Sensor Diameter	Nominal Pipe Size Range (inches)
ONICON fixed range temperature sensor pair	0.25"	1/2 to 48"
100 Ω Platinum RTD pair, w/4-20mA transmitters	0.25"	1/2 to 48"
1000 Ω Platinum RTD pair, 4 wire	5mm	1/2 to 2 1/2"
1000 Ω Platinum RTD pair, 4 wire	6mm	3 to 48"

A pair of temperature sensors per channel must be located so they accurately measure only the temperature of the supply line entering and the return line leaving the portion of the piping system for which the energy measurement is being made.

APPLICATION NOTE: For the Four Channel System-1000, channels 1&2 must use Onicon Solid State temp sensors while channels 3&4 must use 1000 Ohm RTD's.

If possible, find an easily accessible location where field wiring connections can be made from floor level. This will facilitate future service. Place the temperature sensors away from strong sources of electrical noise that might affect the performance of the sensors.

One temperature sensor thermowell will need to be placed in the same pipe with the flow meter. If it is an immersion thermowell, it must be located at least five pipe diameters downstream of the flow meter leaving enough clearance to remove either sensor from the pipe without interference from the other sensor.

THERMOWELLS INSTALLATION SCHEMATICS (CONTINUED)

B. 0.25" Diameter Thermowell

1. Dry Tap Thermowell

Dry tap thermowells are for new construction or scheduled shutdown. The most common installation methods are shown below. Consult ONICON for special applications.

Welded Pipe

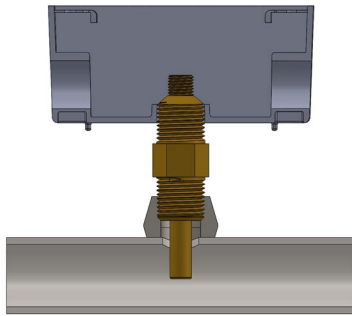

**Threaded Tee
(for 1/2" pipes)**

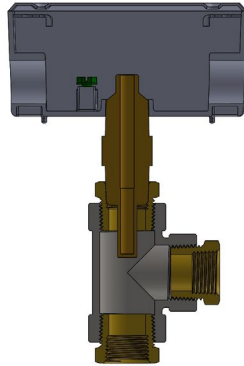

**Threaded Tee
(for 3/4" and larger pipes)**

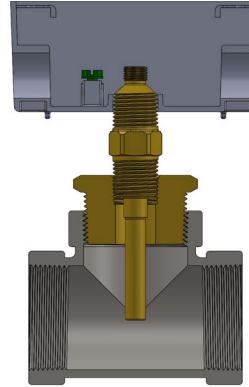

Copper Tee

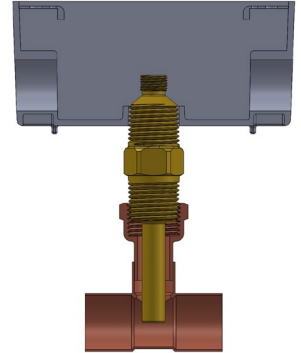

NOTES

1. Thermowell length varies with pipe size.
2. Do not use multiple bushings to reduce the outlet size on threaded tees.

THERMOWELLS INSTALLATION SCHEMATICS (CONTINUED)

B. 0.25" Diameter Thermowell (Continued)

2. Hot Tap Thermowell

Hot tap thermowells are designed for retrofit applications where it is not practical to isolate and drain the pipe section prior to installation. The thermowell is installed through a 1" full port ball valve as shown in the drawing below. A hot tap drilling machine equipped with a 7/8" drill is required to perform this type of installation.

Once the valve assembly has been installed and the hole has been drilled, the thermowell can be inserted into the flow stream without a system shutdown.

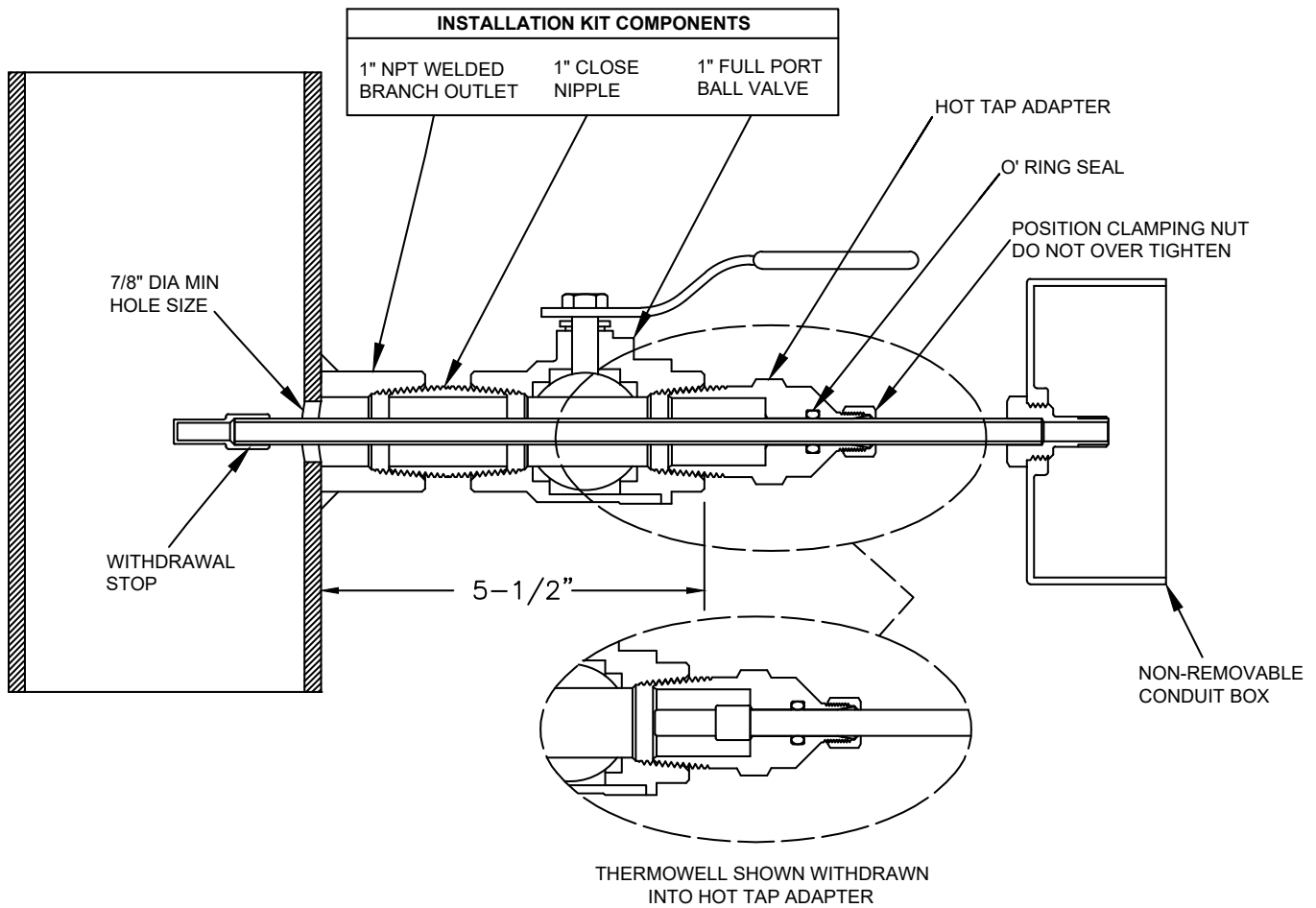

Hot Tap Installation Detail For Thermowell In Welded Pipe

THERMOWELLS INSTALLATION SCHEMATICS (CONTINUED)

C. Clamp-On Thermowell

The two clamp-on temperature sensors must be located such that they only measure the temperature of the supply pipe entering and the return pipe leaving the portion of the piping system for which the energy measurement is being made. Once installed, the pipes and clamp-on thermowells must be fully insulated.

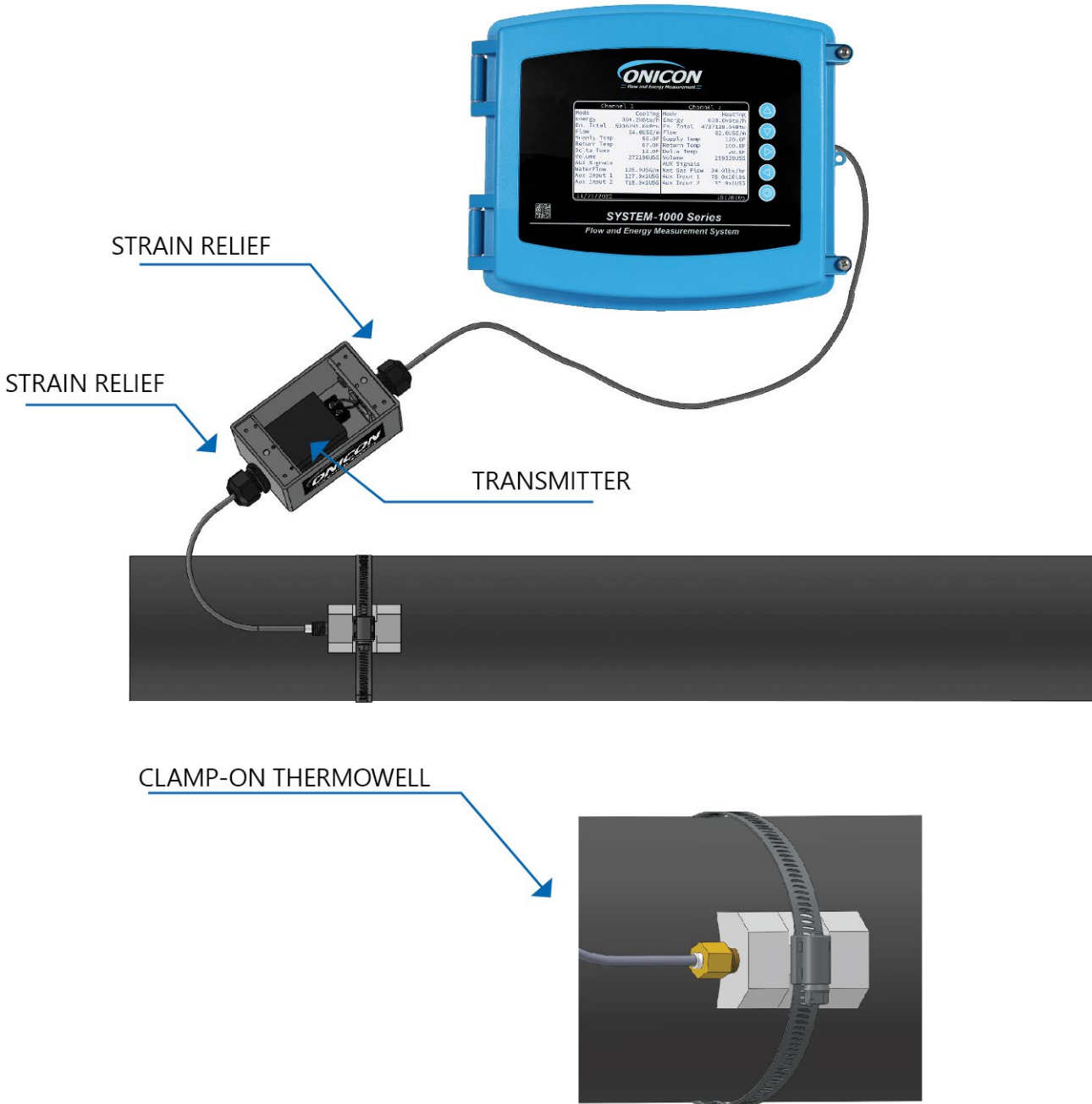

THERMOWELLS INSTALLATION SCHEMATICS (CONTINUED)

D. 5mm Diameter Thermowell

5 mm RTDs are provided with thermowells with 1/2" male NPT process connections. They are designed for use in 1/2" to 2 1/2" line size tees provided by the customer. The RTDs are push-in type and are held in place with a set screw. Depending on the pipe material, the kit may include a copper sweat bushing or a threaded reducer bushing.

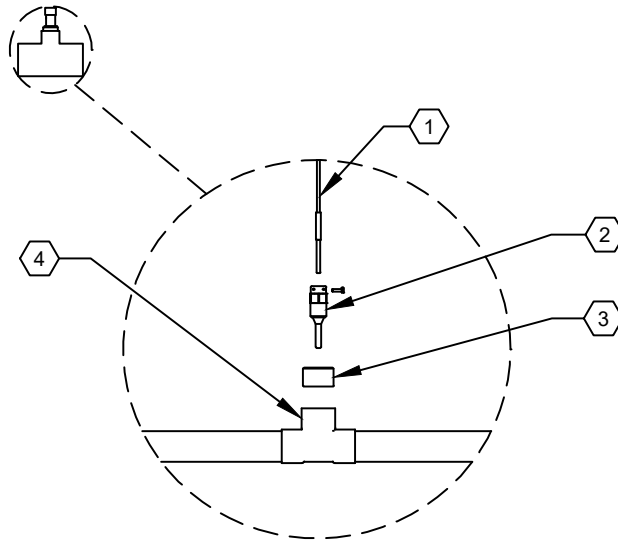

- 1. RTD temperature sensor – provided by ONICON.
- 2. 5 mm diameter thermowell – provided by ONICON.
- 3. 1" solder x 1/2" NPT bushing OR line size x 1/2" bushing – provided by customer or ordered from ONICON.
- 4. Customer supplied line size tee.

THERMOWELLS INSTALLATION SCHEMATICS (CONTINUED)

E. 6mm Diameter Thermowell

6mm RTDs are provided with matching length thermowells with 1/2" male NPT process connections. They are designed for use in 3" and larger diameter pipes. The RTDs are push-in type and are held in place with a set screw. The kit includes two (2) weld-on branch outlets with 1/2" NPT threads.

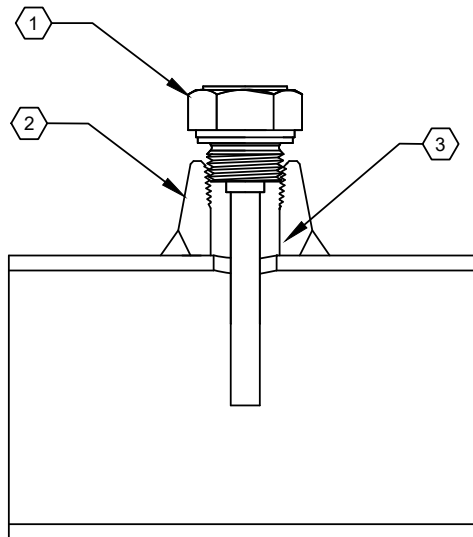

1. 6 mm diameter thermowell - provided by ONICON.
2. 1/2" NPT weld on branch outlet - provided by ONICON.
3. 3/4" minimum hole size.

DIMENSIONS

A. Enclosure Dimensions

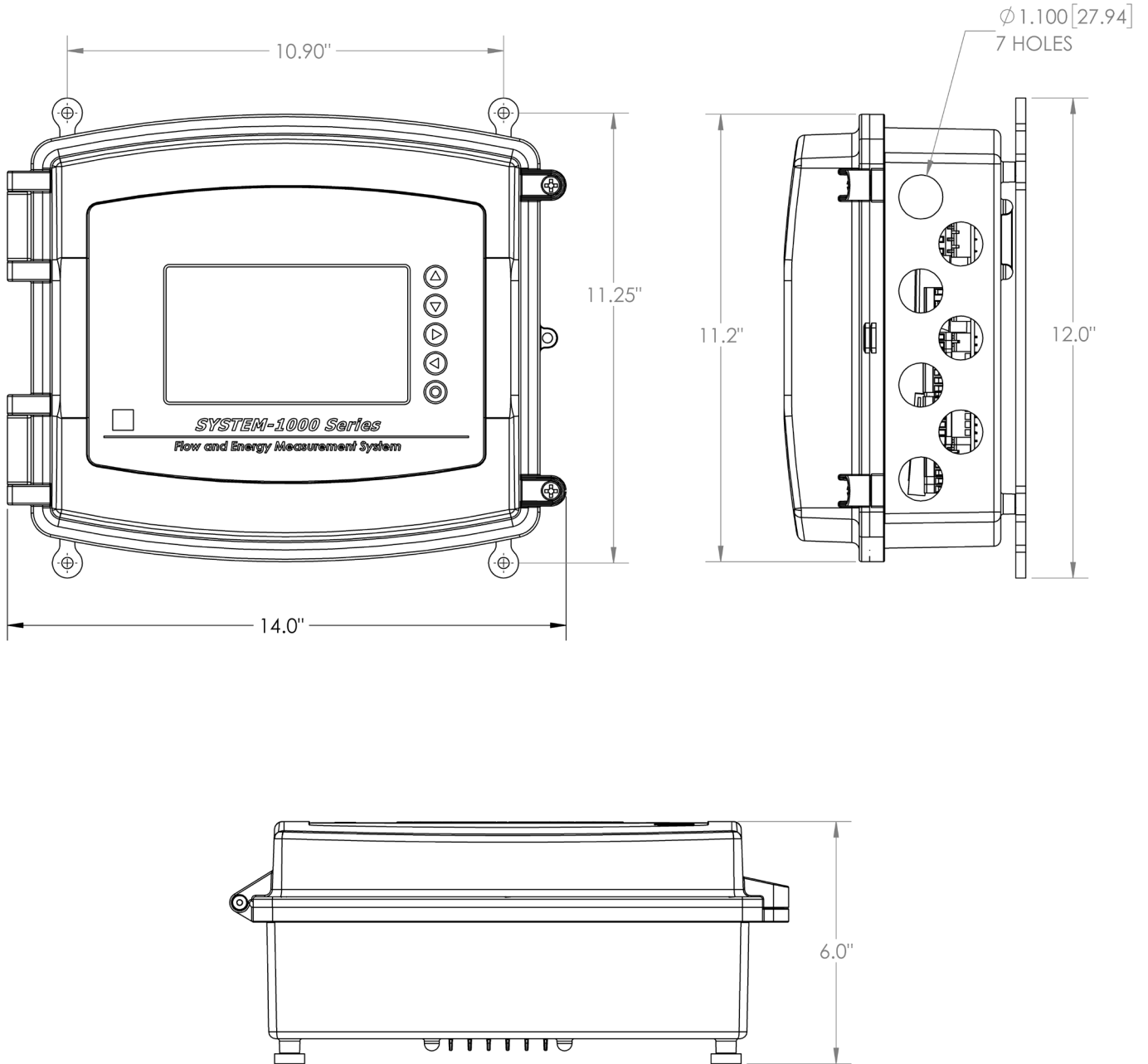

ONE & TWO CHANNEL WIRE CONNECTIONS

I. INPUT POWER

MAIN POWER 24V VERSION	
EARTH GROUND	TB1 EARTH GND
24V NEUTRAL	TB1 NEUTRAL
24V AC/DC LINE	TB1 24V

MAIN POWER 115/230V VERSION	
EARTH GROUND	TB2 EARTH GND
115/230V AC LINE	TB2 LINE IN
115/230V AC NEUTRAL	TB2 NEUTRAL

CHANNEL 1

CHANNEL 2

INPUT CONNECTIONS

II. FLOW METER INPUTS

PRIMARY FLOW METER CH 1		
INPUT TYPE	FREQUENCY	4-20mA
SIGNAL (+)	J7-5	J7-3
COMMON (-)	J7-6	J7-4

PRIMARY FLOW METER CH 1		
INPUT TYPE	FREQUENCY	4-20mA
SIGNAL (+)	J7-5	J7-3
COMMON (-)	J7-6	J7-4

III. TEMP SENSOR INPUT

SUPPLY TEMP INPUT CH1		
4-20mA	4 WIRE RTD	
J8-3 (+)	J8-8	(A) BROWN
J8-4 (-)	J8-7	(A) YELLOW (2 WIRE)
	J8-6	(B) WHITE
	J8-5	(B) GREEN (2 WIRE)

SUPPLY TEMP INPUT CH2		
4-20mA	4 WIRE RTD	
J10-13 (+)	J10-18	(A) BROWN
J10-14 (-)	J10-17	(A) YELLOW (2 WIRE)
	J10-16	(B) WHITE
	J10-15	(B) GREEN (2 WIRE)

RETURN TEMP INPUT CH1		
4-20mA	4 WIRE RTD	
J8-1 (+)	J8-12	(A) BROWN
J8-2 (-)	J8-11	(A) YELLOW (2 WIRE)
	J8-10	(B) WHITE
	J8-9	(B) GREEN (2 WIRE)

RETURN TEMP INPUT CH2		
4-20mA	4 WIRE RTD	
J10-11 (+)	J11-20	(A) BROWN
J10-12 (-)	J11-19	(A) YELLOW (2 WIRE)
	J11-18	(B) WHITE
	J11-17	(B) GREEN (2 WIRE)

IV. AUX FLOW METER INPUT

AUX FLOW METER CH 1		
INPUT TYPE	FREQUENCY	4-20mA
SIGNAL (+)	J7-11	J7-9
COMMON (-)	J7-12	J7-10

AUX FLOW METER CH 2		
INPUT TYPE	FREQUENCY	4-20mA
SIGNAL (+)	J9-19	J10-3
COMMON (-)	J9-20	J10-4

V. DIGITAL INPUT

DIGITAL INPUT CH 1		
INPUT TYPE	DIGITAL IN #1	DIGITAL IN #2
PULSE IN (+)	J12-13	J12-11
PULSE IN (-)	J12-12	J12-10

DIGITAL INPUT CH 2		
INPUT TYPE	DIGITAL IN #3	DIGITAL IN #4
PULSE IN (+)	J12-9	J12-7
PULSE IN (-)	J12-8	J12-6

OUTPUT CONNECTIONS

VI. ANALOG OUTPUT

ANALOG OUTPUT CH 1				
OUTPUT TYPE	ANALOG OUT 1	ANALOG OUT 2	ANALOG OUT 3	ANALOG OUT 4
0-10V (+)	J9-1	J9-4	J9-7	J9-10
4-20mA (+)	J9-2	J9-5	J9-8	J9-11
COMMON (-)	J9-3	J9-6	J9-9	J9-12

ANALOG OUTPUT CH 2				
OUTPUT TYPE	ANALOG OUT 5	ANALOG OUT 6	ANALOG OUT 7	ANALOG OUT 8
0-10V (+)	J11-10	J11-7	J11-4	J12-20
4-20mA (+)	J11-9	J11-6	J11-3	J12-19
COMMON (-)	J11-8	J11-5	J11-2	J12-18

VII. DIGITAL OUTPUT

DIGITAL OUTPUT CH 1				
OUTPUT TYPE	DIGITAL OUT 1	DIGITAL OUT 2	DIGITAL OUT 3	DIGITAL OUT 4
PULSE OUT (+)	J8-13	J8-15	J8-17	J11-15
PULSE OUT (-)	J8-14	J8-16	J8-18	J11-16

DIGITAL OUTPUT CH 2				
OUTPUT TYPE	DIGITAL OUT 5	DIGITAL OUT 6	DIGITAL OUT 7	DIGITAL OUT 8
PULSE OUT (+)	J8-13	J8-15	J8-17	J11-15
PULSE OUT (-)	J8-14	J8-16	J8-18	J11-16

VIII. RS485 COMM OUTPUT

RS485 OUTPUT	
SHIELD	J13-4
GND	J13-3
RS-485 (-)	J13-2
RS-485 (+)	J13-1

FOUR CHANNEL WIRE CONNECTIONS

I. INPUT POWER

MAIN POWER 24V VERSION	
EARTH GROUND	TB1 EARTH GND
24V NEUTRAL	TB1 NEUTRAL
24V AC/DC LINE	TB1 24V

MAIN POWER 115/230V VERSION	
EARTH GROUND	TB2 EARTH GND
115/230V AC LINE	TB2 LINE IN
115/230V AC NEUTRAL	TB2 NEUTRAL

CHANNEL 1	CHANNEL 2	CHANNEL 3	CHANNEL 4
-----------	-----------	-----------	-----------

INPUT CONNECTIONS

II. FLOW METER INPUTS

PRIMARY FLOW METER CH 1		
INPUT TYPE	FREQUENCY	4-20mA
SIGNAL (+)	J7-5	J7-3
COMMON (-)	J7-6	J7-4

PRIMARY FLOW METER CH 2		
INPUT TYPE	FREQUENCY	4-20mA
SIGNAL (+)	J7-11	J7-9
COMMON (-)	J7-12	J7-10

PRIMARY FLOW METER CH 3		
INPUT TYPE	FREQUENCY	4-20mA
SIGNAL (+)	J9-17	J9-15
COMMON (-)	J9-18	J9-16

PRIMARY FLOW METER CH 4		
INPUT TYPE	FREQUENCY	4-20mA
SIGNAL (+)	J9-19	J10-3
COMMON (-)	J9-20	J10-4

III. TEMP SENSOR INPUT

SUPPLY TEMP INPUT CH 1	
4-20mA	
J8-3 (+)	
J8-4 (-)	

SUPPLY TEMP INPUT CH 2	
4-20mA	
J10-13 (+)	
J10-14 (-)	

SUPPLY TEMP INPUT CH 3	
4 WIRE RTD	
J8-8	(A) BROWN
J8-7	(A) YELLOW (2 WIRE)
J8-6	(B) WHITE
J8-5	(B) GREEN (2 WIRE)

SUPPLY TEMP INPUT CH 3	
4 WIRE RTD	
J10-18	(A) BROWN
J10-17	(A) YELLOW (2 WIRE)
J10-16	(B) WHITE
J10-15	(B) GREEN (2 WIRE)

RETURN TEMP INPUT CH 1	
4-20mA	
J8-1 (+)	
J8-2 (-)	

RETURN TEMP INPUT CH 2	
4-20mA	
J10-11 (+)	
J10-12 (-)	

RETURN TEMP INPUT CH 3	
4 WIRE RTD	
J8-12	(A) BROWN
J8-11	(A) YELLOW (2 WIRE)
J8-10	(B) WHITE
J8-9	(B) GREEN (2 WIRE)

RETURN TEMP INPUT CH 3	
4 WIRE RTD	
J11-20	(A) BROWN
J11-19	(A) YELLOW (2 WIRE)
J11-18	(B) WHITE
J11-17	(B) GREEN (2 WIRE)

IV. AUX FLOW METER INPUT

AUX FLOW METER CH 1		
INPUT TYPE	FREQUENCY	4-20mA
SIGNAL (+)	J7-5	J7-3
COMMON (-)	J7-6	J7-4

AUX FLOW METER CH 2		
INPUT TYPE	FREQUENCY	4-20mA
SIGNAL (+)	J7-11	J7-9
COMMON (-)	J7-12	J7-10

AUX FLOW METER CH 3		
INPUT TYPE	FREQUENCY	4-20mA
SIGNAL (+)	J9-17	J9-15
COMMON (-)	J9-18	J9-16

AUX FLOW METER CH 4		
INPUT TYPE	FREQUENCY	4-20mA
SIGNAL (+)	J9-19	J10-3
COMMON (-)	J9-20	J10-4

V. DIGITAL INPUT

DIGITAL INPUT CH 1	
INPUT TYPE	DIGITAL INPUT 1
PULSE IN (+)	J12-13
PULSE IN (-)	J12-12

DIGITAL INPUT CH 2	
INPUT TYPE	DIGITAL INPUT 2
PULSE IN (+)	J12-11
PULSE IN (-)	J12-10

DIGITAL INPUT CH 3	
INPUT TYPE	DIGITAL INPUT 3
PULSE IN (+)	J12-9
PULSE IN (-)	J12-8

DIGITAL INPUT CH 4	
INPUT TYPE	DIGITAL INPUT 4
PULSE IN (+)	J12-7
PULSE IN (-)	J12-6

OUTPUT CONNECTIONS

VI. ANALOG OUTPUT

ANALOG OUTPUT CH 1		
OUTPUT TYPE	ANALOG OUTPUT 1	ANALOG OUTPUT 2
0-10V (+)	J9-1	J9-4
4-20mA (+)	J9-2	J9-5
COMMON (-)	J9-3	J9-6

ANALOG OUTPUT CH 2		
OUTPUT TYPE	ANALOG OUTPUT 3	ANALOG OUTPUT 4
0-10V (+)	J9-7	J9-10
4-20mA (+)	J9-8	J9-11
COMMON (-)	J9-9	J9-12

ANALOG OUTPUT CH 3		
OUTPUT TYPE	ANALOG OUTPUT 5	ANALOG OUTPUT 6
0-10V (+)	J11-10	J11-7
4-20mA (+)	J11-9	J11-6
COMMON (-)	J11-8	J11-5

ANALOG OUTPUT CH 4		
OUTPUT TYPE	ANALOG OUTPUT 7	ANALOG OUTPUT 8
0-10V (+)	J11-4	J12-20
4-20mA (+)	J11-3	J12-19
COMMON (-)	J11-2	J12-18

VII. DIGITAL OUTPUT

DIGITAL OUTPUT CH 1		
OUTPUT TYPE	DIGITAL OUTPUT 1	DIGITAL OUTPUT 2
PULSE OUT (+)	J8-13	J8-15
PULSE OUT (-)	J8-14	J8-16

DIGITAL OUTPUT CH 2		
OUTPUT TYPE	DIGITAL OUTPUT 3	DIGITAL OUTPUT 4
PULSE OUT (+)	J8-17	J11-15
PULSE OUT (-)	J8-18	J11-16

DIGITAL OUTPUT CH 3		
OUTPUT TYPE	DIGITAL OUTPUT 5	DIGITAL OUTPUT 6
PULSE OUT (+)	J11-13	J11-11
PULSE OUT (-)	J11-14	J11-12

DIGITAL OUTPUT CH 4		
OUTPUT TYPE	DIGITAL OUTPUT 7	DIGITAL OUTPUT 8
PULSE OUT (+)	J12-5	J12-3
PULSE OUT (-)	J12-4	J12-2

VIII. RS485 COMM OUTPUT

RS485 OUTPUT	
SHIELD	J13-4
GND	J13-3
RS-485 (-)	J13-2
RS-485 (+)	J13-1

