

F-1000 SERIES

MICROPROCESSOR BASED TURBINE FLOW METER INSTALLATION AND OPERATION GUIDE

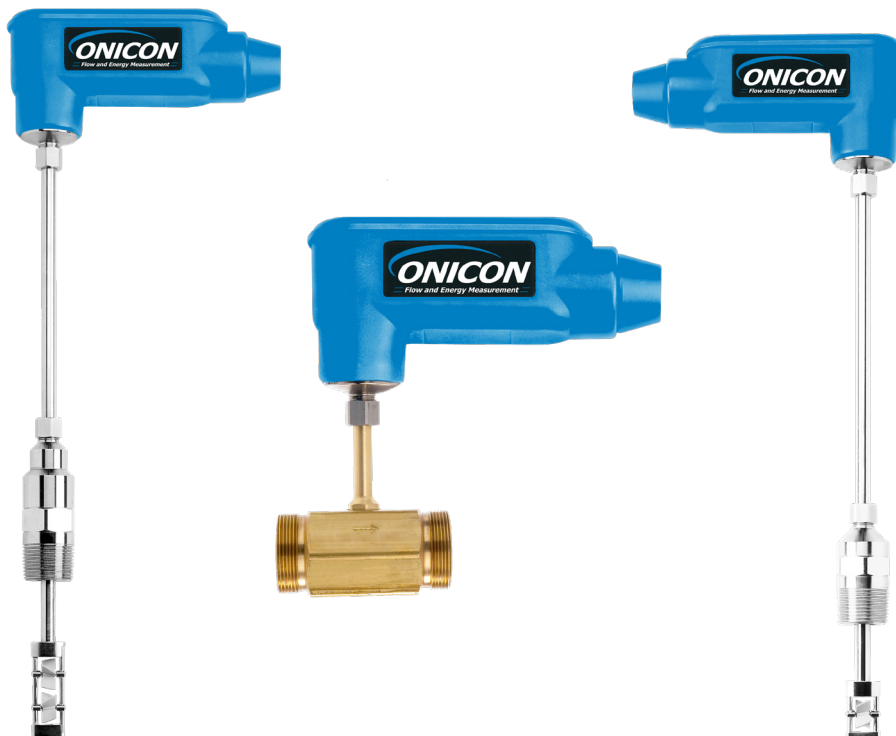

SAFETY INFORMATION

This meter was calibrated at the factory before shipment. To ensure correct use of the meter, please read this manual thoroughly.

Regarding this manual:

- This manual should be passed on to the end user.
- Before use, read this manual thoroughly to comprehend its contents.
- The contents of this manual may be changed without prior notice.
- All rights reserved. No part of this manual may be reproduced in any form without ONICON's written permission.
- ONICON makes no warranty of any kind with regard to this material, including, but not limited to, implied warranties of merchantability and suitability for a particular purpose.
- All reasonable effort has been made to ensure the accuracy of the contents of this manual. However, if any errors are found, please inform ONICON.
- ONICON assumes no responsibilities for this product except as stated in the warranty.
- If the customer or any third party is harmed by the use of this product, ONICON assumes no responsibility for any such harm owing to any defects in the product which were not predictable, or for any indirect damages.

Safety Precautions:

The following general safety precautions must be observed during all phases of installation, operation, service, and repair of this product. Failure to comply with these precautions or with specific WARNINGS given elsewhere in this manual violates safety standards of design, manufacture, and intended use of the product. ONICON Incorporated assumes no liability for the customer's failure to comply with these requirements. If this product is used in a manner not specified in this manual, the protection provided by this product may be impaired.

The following symbols are used in this manual:



WARNING

Messages identified as "WARNING" contain information regarding the personal safety of individuals involved in the installation, operation or service of this product.



CAUTION

Messages identified as "CAUTION" contain information regarding potential damage to the product or other ancillary products.



IMPORTANT NOTE

Messages identified as "IMPORTANT NOTE" contain information critical to the proper operation of the product.

TABLE OF CONTENTS

1.0	INTRODUCTION	4
1.1	Purpose of This Guide	4
1.2	Typical Turbine Flow Meters	4
1.3	Standard Features and Specifications	5
1.4	Model Numbering System	7
1.5	Additional Required Hardware	8
1.6	Serial Number	8
2.0	UNPACKING	9
2.1	Checking That You Have Received Everything	9
3.0	INSTALLATION, REMOVAL & ADJUSTMENT	10
3.1	Installation Site Selection	10
3.2	Insertion Meter Straight Run Requirements	12
3.3	Insertion Meter Mechanical Installation	13
3.3.1	Insertion Meter Installation Kits	14
3.3.2	ONICON Dry Tap Installation Hardware Kits	14
3.3.3	ONICON Hot Tap Installation Hardware Kits	14
3.3.4	Customer Supplied Installation Hardware	15
3.3.5	Confirming the Stack Height	16
3.4	Installing the Insertion Meter	17
3.4.1	Installing the Meter With a Factory Supplied Depth Gauge	18
3.4.2	Calculating Insertion Depth Using Configuration Utility	18
3.5	Removal of the Insertion Meter	19
3.6	Inline Flow Meter Straight Run Requirements and Mechanical Installation	21
3.7	Wiring Connections	22
4.0	START-UP & COMMISSIONING	23
4.1	Helpful Hints for Start-up and Commissioning	23
4.2	Insertion Meter Start-up and Commissioning	24
4.3	Insertion Meter Start-up and Commissioning Worksheet	25
4.4	Inline Meter Start-up and Commissioning	26
4.5	Inline Meter Start-up and Commissioning Worksheet	27
4.6	Troubleshooting Guide	28
5.0	ANALOG ADJUSTMENT PROCEDURE	29
5.1	Diagnostic LEDs	30
APPENDIX		
A	User Connections and Internal Wiring Diagrams	
B	Installation Hardware Instructions	
C	Insertion Turbine Assembly Detail Drawings	

SECTION 1.0: INTRODUCTION

We, at ONICON Incorporated, would like to thank you for purchasing our quality, U.S. made, turbine flow meter. As our valued customer, our commitment to you is to provide fast reliable service and assistance, while continuing to offer you new products to meet your growing flow measurement needs.

1.1 PURPOSE OF THIS GUIDE

We have written this guide to provide the persons responsible for the installation, operation and maintenance of your turbine flow meter with the most specific equipment information they will need. This is NOT an electrical or plumbing trade manual.



WARNING

Please do not permit any persons to install, operate or maintain this equipment unless they have a complete knowledge of their trade skills and are competent to work on high pressure hot and cold water systems, according to their individual trades. Death or permanent injury may result from accidents with these systems.

This guide is the basic reference tool for all ONICON Turbine Flow Meters. If you have not purchased all of the options, there will be references in this manual which are not applicable to your meter(s).

1.2 TYPICAL TURBINE FLOW METERS

ONICON's Turbine Flow Meters measure the velocity of flowing liquids by counting the frequency at which the blades of a rotating turbine pass a fixed electrode. Circuitry within the flow meter electronics enclosure then converts the rotational rate to digital and/or analog signals which are transmitted via a connecting cable to any of ONICON's display devices, BTU meters and/or a data acquisition system.

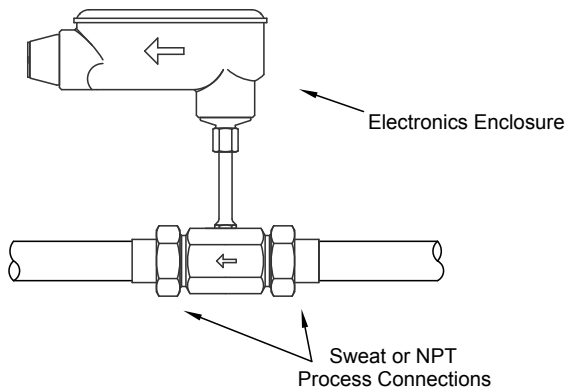

Inline Meter

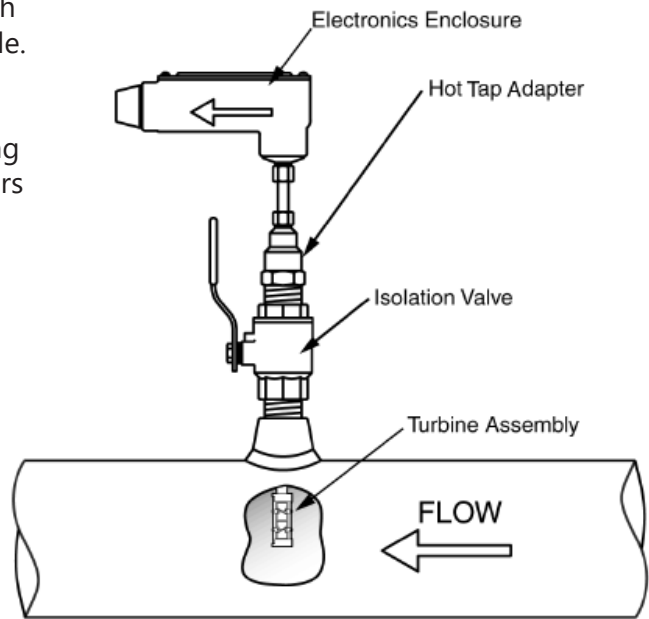

Insertion Meter

1.3 STANDARD FEATURES AND SPECIFICATIONS

(Refer to specification sheet for particular model to obtain additional details)

MODEL F-11XX AND F-12XX TRANSMITTER		
PERFORMANCE	INSERTION ACCURACY	± 1% of reading from 3 to 30 ft/s (10:1 range) ± 2% of reading from 0.4 to 20 ft/s (50:1 range)
	INLINE ACCURACY	± 2% of reading from 0.8 to 38 GPM (50:1 range)
	MINIMUM CONDUCTIVITY ¹	Default range: 100-5000 µS/cm Extended range as low as 5 µS/cm
INPUT POWER	Input power based on model number	
	F-1XXX-00	24 VAC @ 65 mA, 1.6 VA 24 VDC @ 30 mA, 1 W
	F-1XXX-10	24 VAC @ 115 mA, 2.8 VA 24 VDC @ 60 mA, 1.5 W
	F-1XXX-11	24 VAC @ 150 mA, 3.6 VA 24 VDC @ 75 mA, 2W
I/O SIGNAL**	AVAILABLE OPTIONS	<ul style="list-style-type: none"> • Frequency output • Scaled pulse (dry contact) output • Analog output • Isolated analog output
	FREQUENCY OUTPUT	0-15V peak pulse, maximum Hz
	SCALED PULSE/ ALARM OUTPUT	Isolated solid state dry contact Contact rating: 100 mA, 50 V Contact duration: Field programmable; 50, 100, 500 or 1000 ms
	ANALOG OUTPUT	Field programmable, 4-20 mA, 0-10 V, or 0-5 V
	ISOLATED ANALOG OUTPUT	Field programmable, 4-20 mA, 0-10 V, or 0-5 V
ELECTRONICS ENCLOSURE**	AVAILABLE OPTIONS	<ul style="list-style-type: none"> • Default Configuration: Cast aluminum, epoxy coated weather-tight NEMA 4 rated enclosure. • Bluetooth Configuration: Cast aluminum, acetal plastic, and epoxy coated weathertight NEMA 4 rated enclosure.
	AMBIENT CONDITIONS	-5°F to 160°F
ELECTRICAL CONNECTIONS**	AVAILABLE OPTIONS	<ul style="list-style-type: none"> • PVC jacketed cable, pig tail with ½" NPT conduit connection • Plenum rated cable with indoor DIN connector • Shortened PVC jacket cable with Deutsch connector
BLUETOOTH®	VERSION	Bluetooth v5.1, Low Energy (BLE)
	MODE	Single
	CONNECTIVITY RANGE	Up to 50 ft

¹ Conductivity can be lower depending on application criteria . Contact factory for application assistance.

*Specifications subject to change without notice.

**See model codification for additional information regarding option selections.

MODEL F-11XX AND F-12XX SENSOR		
PERFORMANCE	SENSING METHOD	Electronic impedance sensing (non-magnetic and non-photoelectric)
	ACCURACY	± 0.5% of reading at calibrated velocity
OPERATING CONDITIONS	FLUID TEMPERATURE	Low temp: -20°F to 150°F continuous High temp: 150°F to 280°F continuous, 300°F peak ²
	MAXIMUM OPERATING PRESSURE	400 psi maximum
	INSERTION PRESSURE DROP	Less than 0.16 psi at 8 ft/s, decreasing in larger pipes and lower velocities
	INLINE PRESSURE DROP	0.48 psi at maximum flow rate
CONSTRUCTION MATERIALS**	AVAILABLE OPTIONS	<ul style="list-style-type: none"> • Electroless nickel plated brass • 316 stainless steel - The use of 316 Stainless Steel is required for non-metallic pipe, condensate, hot water over 250°F, and NSF-potable water. • Bronze body³
PIPE SIZE RANGE	INSERTION	1¼ - 72" nominal diameter (1" available with ONICON copper tee)
	INLINE	Threaded or sweat union fittings - ¾" or 1" nominal diameter
PROCESS CONNECTIONS	INSERTION	1" NPT adapter
	INLINE	Coupling adapters based on pipe material
APPROVAL	SAFE DRINKING WATER	NSF/ANSI 61
	LEAD CONTENT VERIFICATION	NSF/ANSI 372

OPERATING RANGE FOR COMMON PIPE SIZES					
<i>(±2% accuracy begins at 0.4 ft/s)</i>					
PIPE SIZE (inches)	FLOW RATE (GPM) (0.1 ft/s to 20 ft/s)	PIPE SIZE (inches)	FLOW RATE (GPM) (0.1 ft/s to 20 ft/s)	PIPE SIZE (inches)	FLOW RATE (GPM) (0.1 ft/s to 20 ft/s)
¾	0.4 - 38	4	8 - 800	18	120 - 14,600
1	0.4 - 38	6	15 - 1,800	20	150 - 18,100
1¼	0.8 - 95	8	26 - 3,100	24	230 - 26,500
1½	1 - 130	10	42 - 4,900	30	360 - 41,900
2	2 - 210	12	60 - 7,050	36	510 - 60,900
2½	2.5 - 230	14	72 - 8,600		
3	4 - 460	16	98 - 11,400		

² Insertion meters operating at or above 250°F require 316 SS construction option.

³ Inline meters only

*Specifications subject to change without notice.

**See model codification for additional information regarding option selections.

1.4 MODEL NUMBERING SYSTEM

METER ORDERING INFORMATION

F-1000 Meter Model Number Codification = F-1ABB-CC-DD-EFGH-SPC

<p>A = Number of Turbines 1 = Single turbine 2 = Dual turbine</p> <p>BB = Meter Type 00 = Insertion 34 = ¾" Inline 01 = 1" Inline</p> <p>CC = Outputs 00 = Frequency and scaled pulse (dry contact) output 10 = Frequency, analog and scaled pulse (dry contact) output 11 = Frequency, isolated analog and scaled pulse (dry contact) output</p> <p>DD = Pipe Size Range A1 = 1" - 2.5" (F-1100 only) B2 = 1" - 4.0" (F-1100 only) C3 = 2.5" - 10" D4 = 2.5" - 16" E5 = 2.5" - 22" F6 = 2.5" - 72" 00 = Inline</p> <p>E = Wetted Adapter Material 1 = Ni plated brass 2 = 316 SS¹ 3 = Bronze body, inline</p>	<p>F = Electronics Enclosure 2 = NEMA 4 weathertight enclosure</p> <p>G = Wiring Connection 2 = 10' PVC jacketed cable, pig tail with ½" conduit adapter 5 = 10' Plenum rated cable, DIN connector with ½" conduit adapter 0 = 1' PVC jacketed cable with Deutsch Connector</p> <p>H = Process Adapter 1 = 1" NPT adapter, medium temperature (temp. ≤ 150°F) 2 = 1" NPT adapter, high temperature (temp. ≤ 280°F) 3 = 1" NPT adapter, NSF certified, domestic water (temp. ≤ 200°F) 9 = Inline, coupling adapters based on pipe material</p> <p>SPC = Special Configurations 503 = Bluetooth interface (For F = 2 only)</p>
--	---

¹ Required for certain applications and non-metallic pipes.

1.5 ADDITIONAL REQUIRED HARDWARE

All ONICON insertion type meters can be installed and removed via a 1" or larger full port ball valve without stopping flow. The terms "Dry Tap" and "Hot Tap" refer to the installation method of the isolation valve kit only.

Dry Tap Installation Hardware: For new construction or scheduled shutdown; once kit is installed, the flow meter can be installed or removed without system shutdown.

Hot Tap Installation Hardware: For applications which require the access hole in the pipe to be drilled through the valve using a wet tap drilling machine while the hydronic system is pressurized and operating.

NOTE: Installation hardware materials vary greatly based on pipe material, pipe size and dry tap vs. hot tap versions.

See Appendix B for installation hardware instructions.

1.6 SERIAL NUMBER

Serial Number

The serial number of your flow meter is located on a label on the side of the electronics enclosure. The model number is also listed on this label. The serial number is a unique identifier that you should refer to, along with the model number, whenever you contact ONICON for assistance regarding your meter.

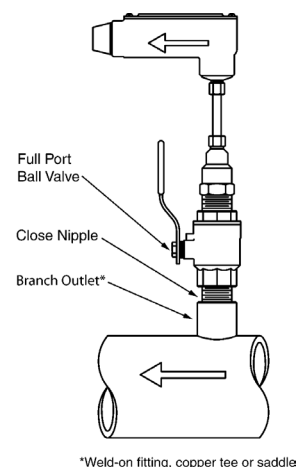

SECTION 2.0: UNPACKING

Turbine flow meters are generally shipped in one package unless optional hardware or equipment is ordered. This package may contain up to two complete meters along with the optional installation kits. Any display equipment ordered with the meters, will be packed separately. Please open all packages with caution to avoid damaging to their contents. In the event that anything is damaged when you receive it, notify the shipping company immediately and the ONICON customer service department. Most products are shipped insured unless the customer specifically requests otherwise.

2.1 CHECKING THAT YOU HAVE RECEIVED EVERYTHING

The Documentation

Enclosed with each flow meter is a comprehensive documentation package which includes the following items:

- Installation and Operation Guide
- Flow Meter Calibration Certificate

Please notify the ONICON customer service department if any documents are missing.

The Flow Meter

The flow meter was carefully packed prior to shipment and should arrive without any damage. Prior to installation, inspect for physical damage such as broken turbine blades or a damaged stem.

- Test the turbine(s) to see that they rotate freely when you gently blow on them parallel to their shafts.
- Make sure that the threads on the insertion meter hot tap adapter have not been damaged.
- Inspect the insertion meter stem for bends or other damage. The stem forms the seal against liquid leakage as it slides through an 'O' ring inside the hot tap adapter. Deep scratches may cause leakage.
- The serial and model numbers on the laminated wiring connection/calibration data tag attached to the meter should match the numbers on the tag mounted directly on the flow meter. Be sure that the unit was calibrated to the correct pipe size and flow range.

SECTION 3.0: INSTALLATION, REMOVAL & ADJUSTMENT



WARNING

Insertion flow meters may often be installed in pipes which are under high pressure. Accidents with these systems can cause serious injury or death. Only persons experienced with high pressure systems and related knowledge in the heating, cooling and fluid metering fields should attempt to install adjust or remove the flow meter. Carefully read the installation and removal instructions in this manual before performing any work on these meters.

ONICON will be happy to assist with technical recommendations and to provide guidance by telephone or e-mail. On-site field engineering, installation and service is also available at additional cost.

3.1 INSTALLATION SITE SELECTION

Install the flow meter where it will be accessible for personnel to perform necessary periodic maintenance. The clearance required for insertion meter installations is typically 23"-36" from the pipe wall to the nearest obstruction above the valve assembly. This clearance dimension will increase with large diameter pipes. Allow at least 6" of clearance for inline meter installations. The environment should be free of corrosive liquids/fumes, temperature extremes and heavy vibration. The following information should be used as a guide to the proper location for installing the meter.

GENERAL PRACTICES:

1. For best results, install the flow meter in a straight run of pipe, free of bends, tees, valves, transitions, and obstructions.
2. Straight run requirements vary based on the nature of the upstream obstruction. Review the following pages for guidelines in determining minimum upstream straight run requirements based on the nature of the obstruction.

Note: Depending upon specific location details, more or less straight run may be required to produce a satisfactory flow profile.

3. If there is insufficient straight run, allow 80% of the run upstream and 20% of the run downstream.



IMPORTANT NOTE

Always use the maximum available straight run. When more than the minimum required straight run is available, place the meter such that the excess straight run is upstream of the meter location.

INSERTION AND INLINE FLOW METER SITE SELECTION GENERAL GUIDELINES (Shown with Insertion Meter)

- Install in vertical or horizontal pipe.
- For horizontal pipe position meter anywhere in upper 240°

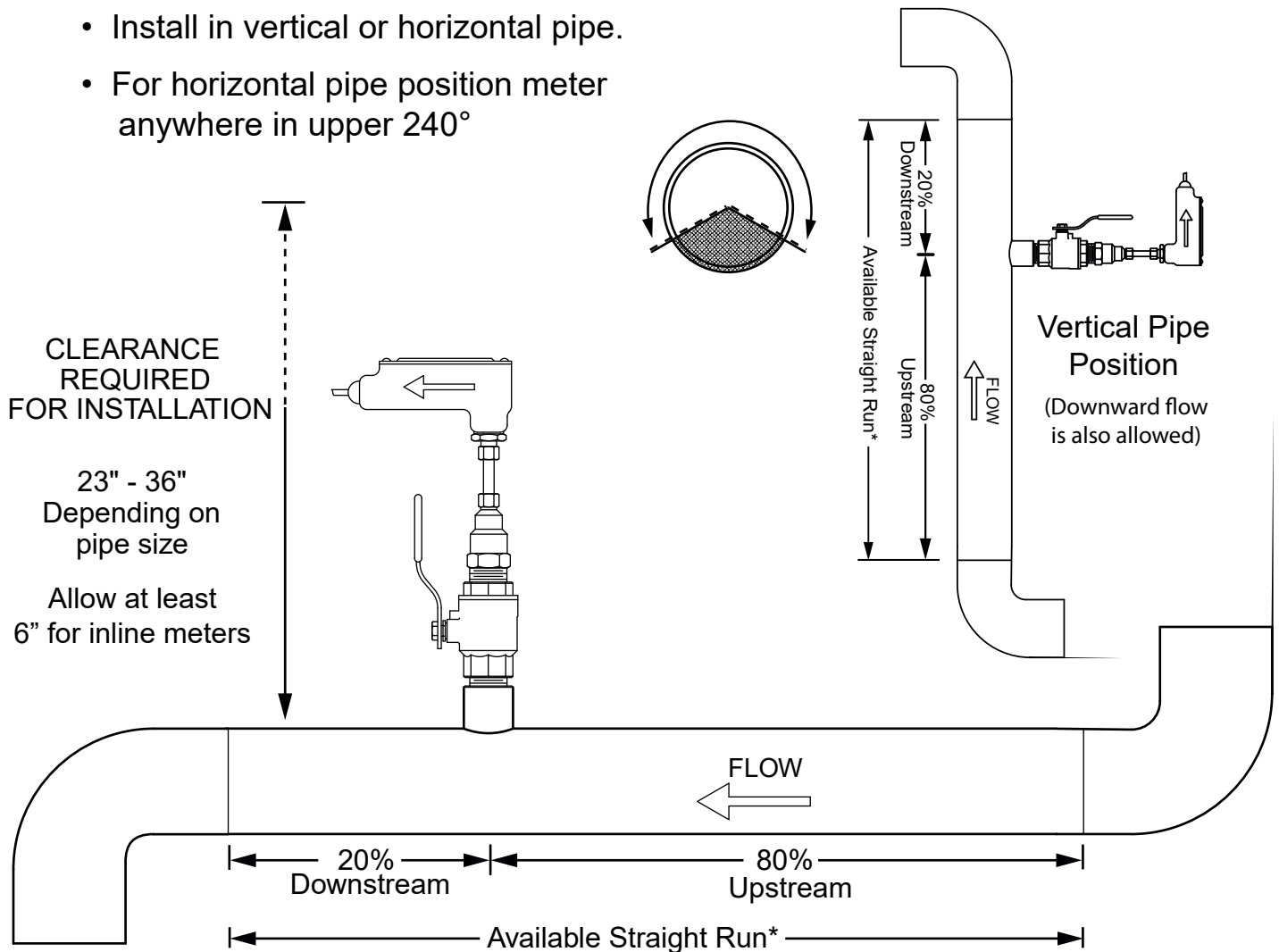

*See following pages for model specific straight run requirements.

EVALUATING UPSTREAM PIPING CONDITIONS

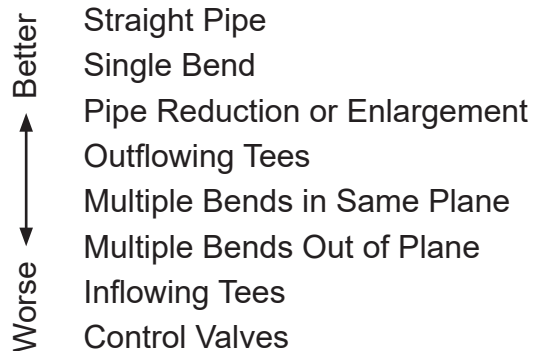

3.2 INSERTION METER STRAIGHT RUN REQUIREMENTS

Series F-1100 Single Turbine Flow Meters

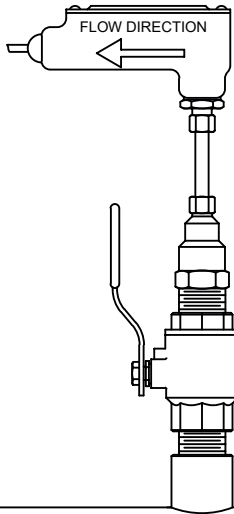

GENERAL PRACTICES

1. For best results, install the flow meter in a straight run of pipe, free of bends, tees, valves, transitions, and obstructions for a distance of at least 20 pipe diameters upstream and 5 diameters downstream.
2. Longer straight runs may be required in applications where the meter is placed downstream from devices which cause unusual flow profile disruption or swirl, for example, modulating valves or two elbows in close proximity and out of plane, etc.
3. If there is not sufficient straight run, allow 80% of the run upstream and 20% of the run downstream. If the total length of straight run is less than 20 diameters, performance may seriously degrade, and consideration should be given to changing to the series F-1200 Dual Turbine Flow Meter.

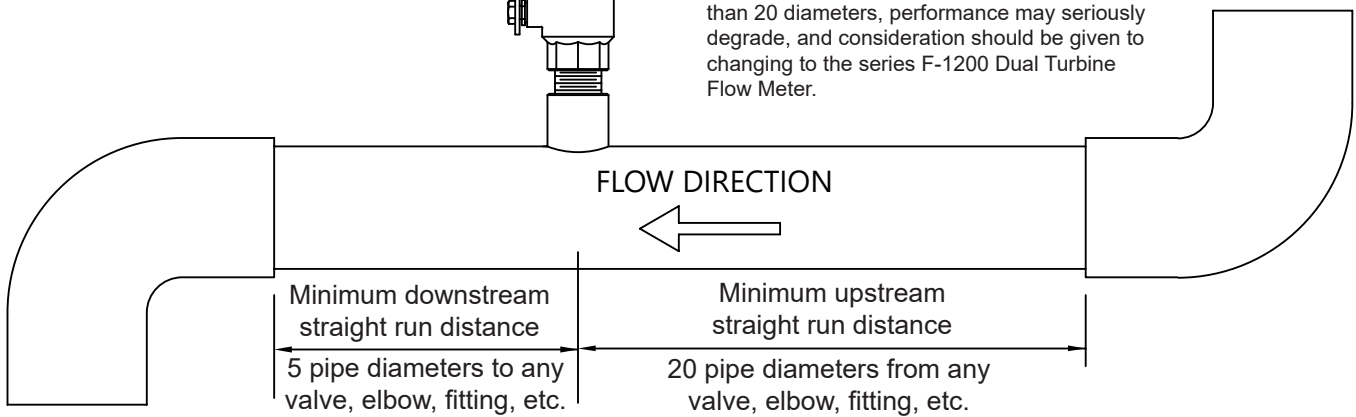

Series F-1200 Dual Turbine Flow Meters

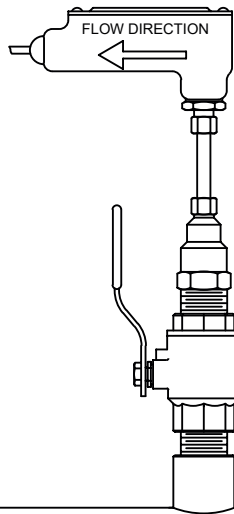

GENERAL PRACTICES

1. For best results, install the flow meter in a straight run of pipe, free of bends, tees, valves, transitions, and obstructions for a distance of 10 pipe diameters upstream and 5 diameters downstream.
2. Longer straight runs may be required in applications where the meter is placed downstream from devices which cause unusual flow profile disruption or swirl, for example, modulating valves or two elbows in close proximity and out of plane, etc.
3. If there is not sufficient straight run, allow 80% of the run upstream and 20% of the run downstream.

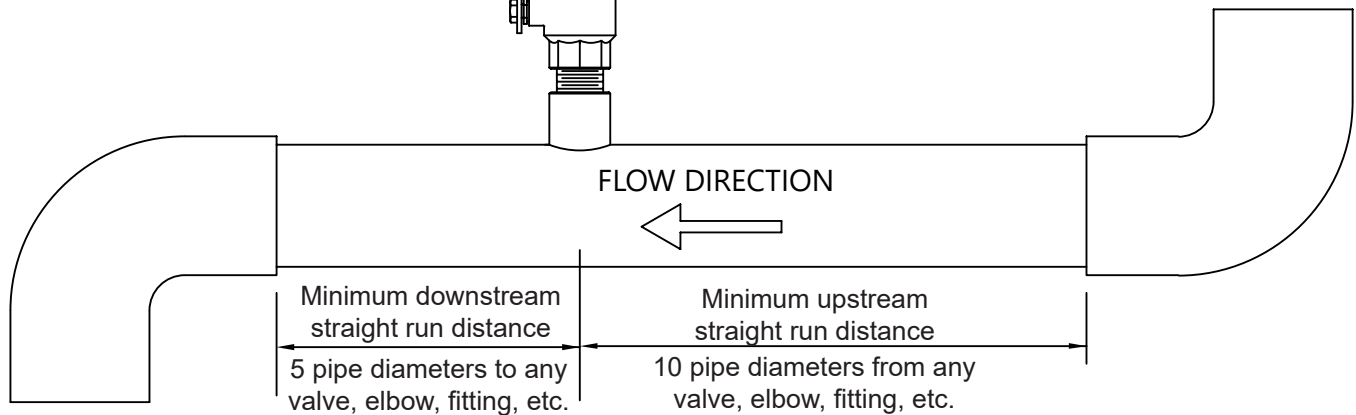

3.3 INSERTION METER MECHANICAL INSTALLATION

ONICON Insertion Turbine Flow Meters employ a hot tap adapter design that allows for insertion and removal, when necessary, without interrupting flow and draining the pipe. To take advantage of this feature, the flow meter must be installed through an isolation valve. The installation must also allow for sufficient overhead clearance to fully extract the meter, and a full 1" opening in the pipe wall is required to clear the sensor head and allow for insertion. Make sure that your valves and fittings are full port and at least 1" in actual internal diameter.

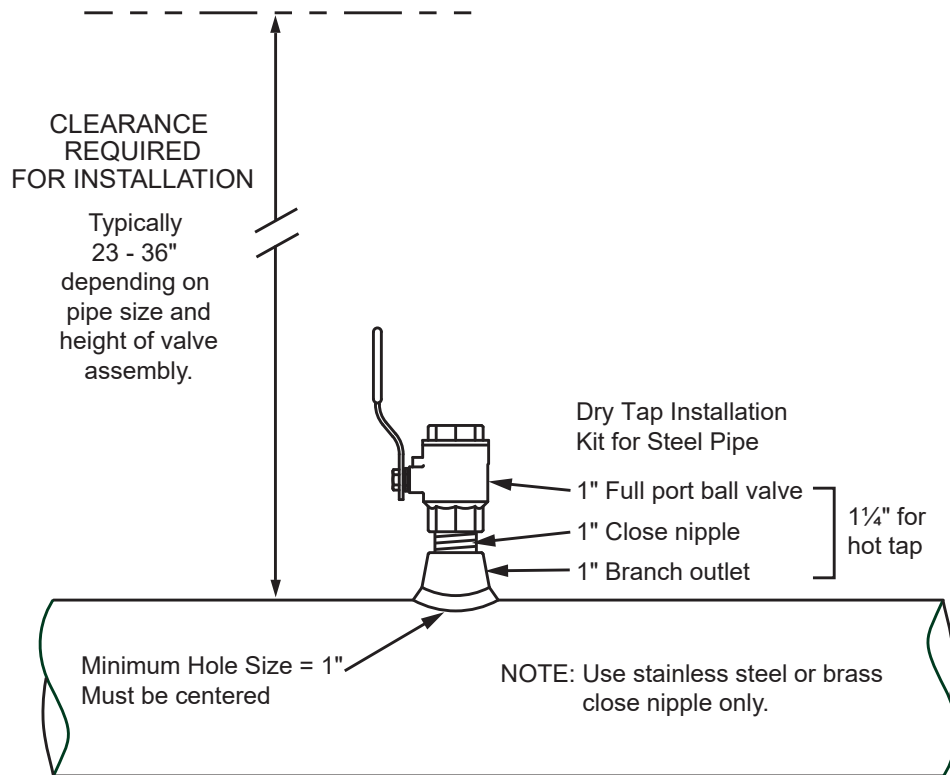

CAUTION



ONICON insertion style flow meters must be installed through a valve assembly. Failure to do so negates the ability to remove the meter without shutting down flow and draining the system. It will also result in an excessive amount of stem protruding from the pipe. Excessive stem lengths unnecessarily expose the meter to incidental damage.

IMPORTANT NOTE



Flow meters installed through oversized access holes will be subjected to undesirable turbulence that may affect the accuracy of the meter.

3.3.1 Insertion Meter Installation Kits

ONICON offers a wide range of installation hardware kits for commonly used pipe materials. The kits are specifically designed for ONICON insertion flow meters, and their use is recommended. Refer to Appendix B of detailed information regarding ONICON installation hardware kits.

The use of ONICON installation hardware kits accomplishes two important objectives. First, it ensures that the proper hardware is used. Second, it simplifies order processing by standardizing the dimensions of the installation hardware.

ONICON installation hardware kits consist of three separate component parts:

Some type of threaded branch outlet,



An interconnecting close nipple,



And a full port isolation valve.



Different pipe materials require different branch outlets and may include additional bushings to properly size the opening.



3.3.2 ONICON Dry Tap Installation Hardware Kits

Dry Tap installation hardware kits are designed to be installed on piping systems that are drained and at atmospheric pressure. The access hole is drilled (1" minimum) prior to installation of the branch outlet with 1" NPT threads, the close nipple and full port ball valve. Once the isolation valve is installed, the piping system can be flushed, filled and pressurized. The flow meter may now be inserted or removed by hand without having to stop flow or drain the system. Please read all instructions before proceeding with meter insertion.

3.3.3 ONICON Hot Tap Installation Hardware Kits

ONICON offers an alternative installation hardware kit when it is not practical to relieve pressure and drain the system. In this case, a 1 1/4" branch outlet, a close nipple and a 1 1/4" full port ball valve are installed first. Then, a hot tap drilling apparatus is used to drill a 1" diameter hole through the valve. This eliminates the need to stop flow and drain the pipe. Please read all instructions before proceeding with meter insertion.

3.3.4 Customer Supplied Installation Hardware

There are occasions where circumstances require that the customer provide the installation hardware or that the flow meter be installed through existing hardware. In these cases, it is important to confirm that the installation hardware is suitable for use with the flow meter provided by ONICON before it is installed. The installation must allow for sufficient overhead clearance to fully extract the meter, must not be too tall where the meter cannot reach the appropriate depth, and a full 1" opening in the pipe wall is required to clear the sensor head and allow for insertion. Make sure that your valves and fittings are full port and at least 1" in actual internal diameter.

Installation hardware generally consists of three separate component parts:

Some type of threaded branch outlet,



An interconnecting close nipple,



And a full port isolation valve.

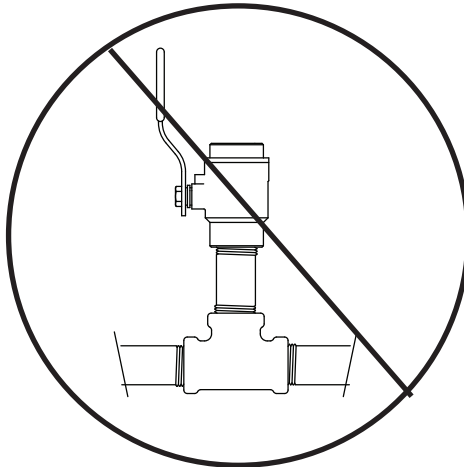

IMPORTANT NOTE

Do not use threaded steel or slip PVC tees to provide the 1" opening in the pipe. Tees of this type will cause significant errors in the flow measurement.



CAUTION

In order to provide the flow meter with the correct stem length, ONICON must know the overall height of the installation hardware as measured from the outside wall of the pipe to the top of the valve where the meter is installed.



CAUTION

Use stainless steel or brass nipple only.

3.3.5 Confirming the Stack Height

ONICON Insertion Turbine Flow Meter stem lengths vary according to the pipe diameter and the height of the installation hardware stack. ONICON records the stack height dimension provided by the customer at the time of order entry, and the information is used to size the stem. This dimension is shown on the laminated insertion depth gauge tag attached to the meter.

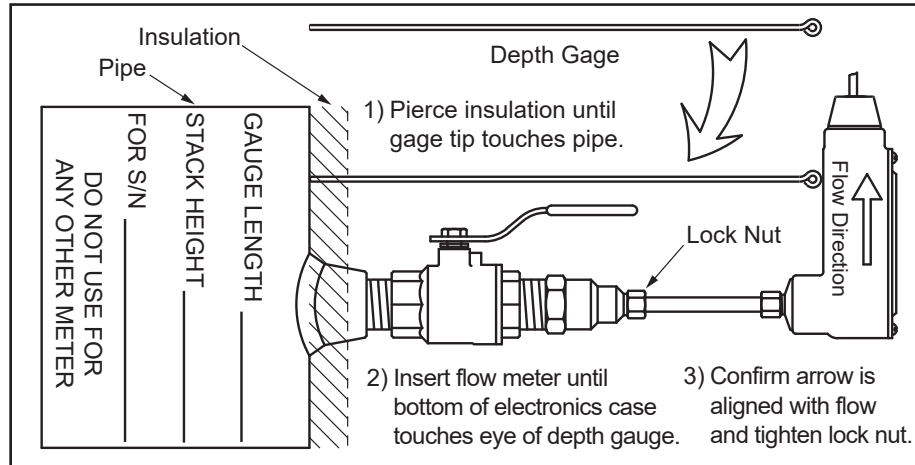

Prior to installing the meter, confirm that the stack height recorded on the tag is close to the actual stack height. Flow meter stems are intentionally over sized to allow for variations of at least 2" in the stack height. Contact ONICON prior to installation if there are any questions regarding stack height or stem length. This will allow ONICON to offer you credit for your meter if you decide to exchange the meter for one with a different stem length. Returns may be subject to a restocking fee.

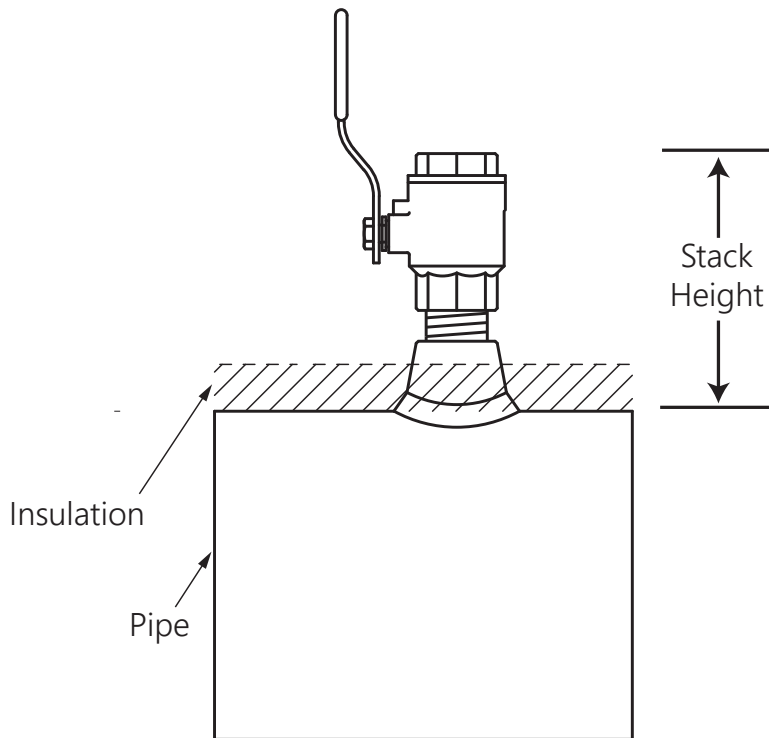

3.4 INSTALLING THE INSERTION METER



WARNING

SYSTEM MAY BE UNDER HIGH PRESSURE. When installing the meter, adjusting its position or removing the meter, be sure to hold the electronics enclosure firmly by hand before SLOWLY loosening the positioning clamping nut. Failure to do this will allow the pressure to suddenly and rapidly force the meter from the pipe causing serious injury. The meter could also be damaged or break apart causing a break in the water seal with the resultant loss of large amounts of water. The hand effort required to hold the meter will be 0.11 times the pipe pressure.

Begin by calculating the effort that will be required to hold the meter. Establish adequate footing for this task, taking extra caution when working from a ladder or platform. Use the following formula:

$$E=0.11 \times P$$

Where: **E** = effort in pounds

P = system pressure in pounds per square inch

Example: In a 300 PSI system, 33 pounds of effort is required to insert the meter into the pipe.



WARNING

When you are ready to refill the system, make sure that all lines are filled with water before inserting the turbine assembly into the stream. If the lines are not filled, air may interrupt the flowing stream and damage the turbine assembly. A greater danger is that if this is a hot water system, some water may flash into steam and exceed the high temperature limit for the turbine and its mechanical assembly. This flash over could exceed the pressure ratings of the meter and the assembly could fail allowing steam and hot water to escape causing serious injury.

1. After fitting the necessary plumbing hardware, flush the entire system so that it is free of flux, solder and slag.
2. Prepare to install the flow meter by loosening the clamping nut and withdrawing the turbine assembly fully into the hot tap adapter.
3. Next, thread the adapter on to the ball valve using a paste type thread sealant. Do not use Teflon tape as torn strands of the tape may wind around the turbine, slowing down or even stopping the turbine.
4. Check the installation for leaks by slightly opening the ball valve. An 'O' ring in the adapter seals the meter stem against leakage. If there are any leaks around the clamping nut or stem, **DO NOT ATTEMPT TO STOP THE LEAKAGE BY OVERTIGHTENING THE CLAMPING NUT. Damage to this nut or the clamping ring under the nut may prevent the assembly from properly holding the meter in the pipe.** The clamping nut is not part of the sealing mechanism. Any leaks in this area indicate that the 'O' ring is not sealing properly and you must contact the factory for assistance.

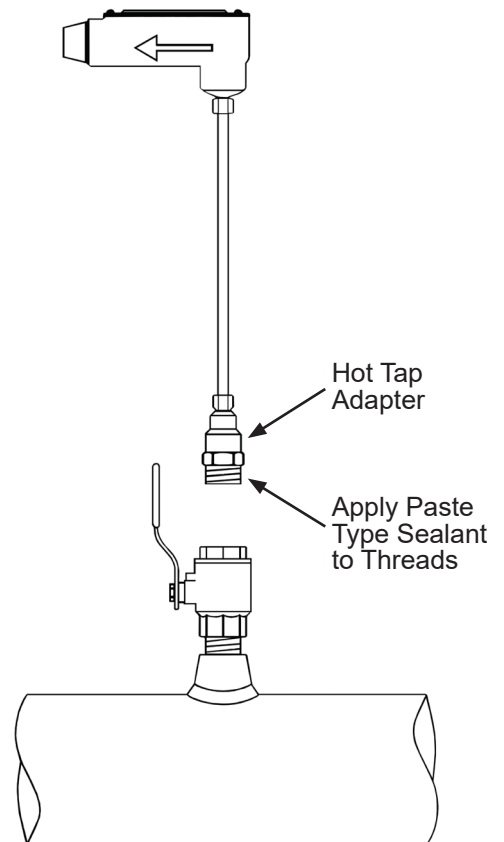

3.4.1 Installing the Meter with a Factory Supplied Depth Gauge:

1. Open valve completely, loosen the position clamping nut, and insert the meter until the bottom of the electronics case touches the eye of the depth gauge. (Pierce insulation with gauge until the tip touches the pipe.)
2. Position the electronics enclosure parallel to the pipe in the proper direction relative to the flow. This will position the turbine with its axis in line with the flow and in the correct direction.
3. Tighten the position clamping nut. **Contact ONICON for assistance when installing a meter without a depth gauge.**

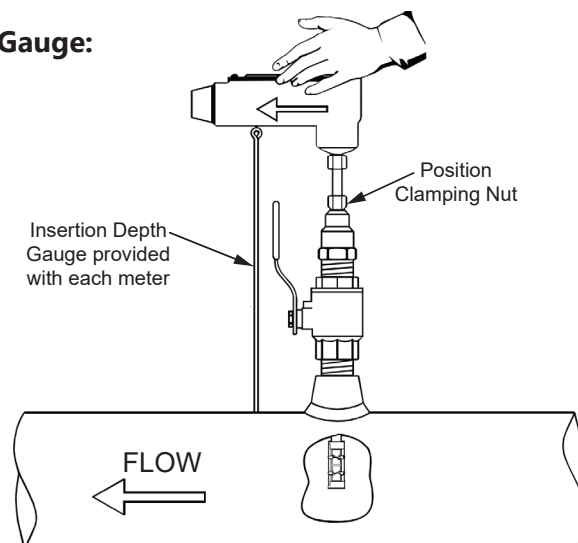

CAUTION

Do not release the flow meter until you have tightened the position clamping nut enough to hold the flow meter in the desired position. This will require less torque than you might think, so be careful not to overtighten it and risk damaging the adapter, nut or stem.



IMPORTANT NOTE

For installations with a limited straight run of pipe (less than the recommended distances shown on pages 10), adjustments in insertion depth may be needed to compensate for velocity flow profile variations. Please contact the factory for information on velocity flow profiling for determining the average velocity location in undeveloped flow locations.



WARNING

If adjustment of the meter depth is required, the same procedure must be followed as if the meter were being removed. Please carefully read the section below on removal of the meter. Remember, the meter may be under high pressure and failure to follow the procedure may result in serious injury.

3.4.2 Calculating Insertion Depth Using Configuration Utility

Inserting the ONICON turbine meter to the proper depth is critical in ensuring that the meter is measuring at the average velocity point in the pipe.

If the turbine meter is provided without a depth gauge, or if the calibrated pipe size is changed in the field, the insertion depth can be acquired with the use of the Smart Turbine Meter Configuration Utility.

This utility can be acquired for free from ONICON's website:

www.onicon.com/TurbineMeter_Configuration.html

A complete guide to the utility can also be acquired from ONICON's website. The manual you are currently reading will not describe in detail how to install and use the utility in whole.

In the "Pipe Selection" tab of the Smart Turbine Meter Configuration Utility, the "Gauge Length" will dynamically change based on the pipe size programmed into the meter. This is the distance required to properly set the depth at installation.

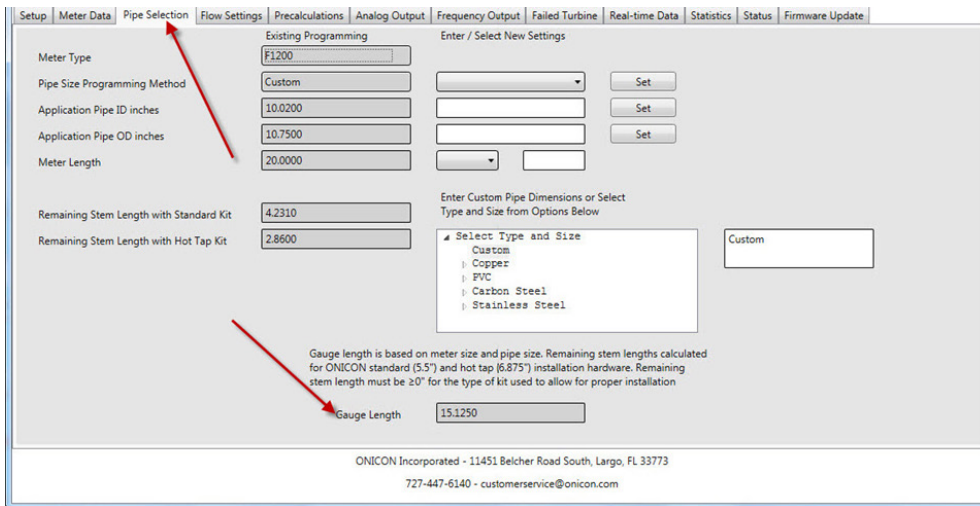

If the insertion meter is to be installed on a pipe with insulation, the insulation thickness can be subtracted from the "Gauge Length" to acquire the measured distance needed to properly insert the meter.

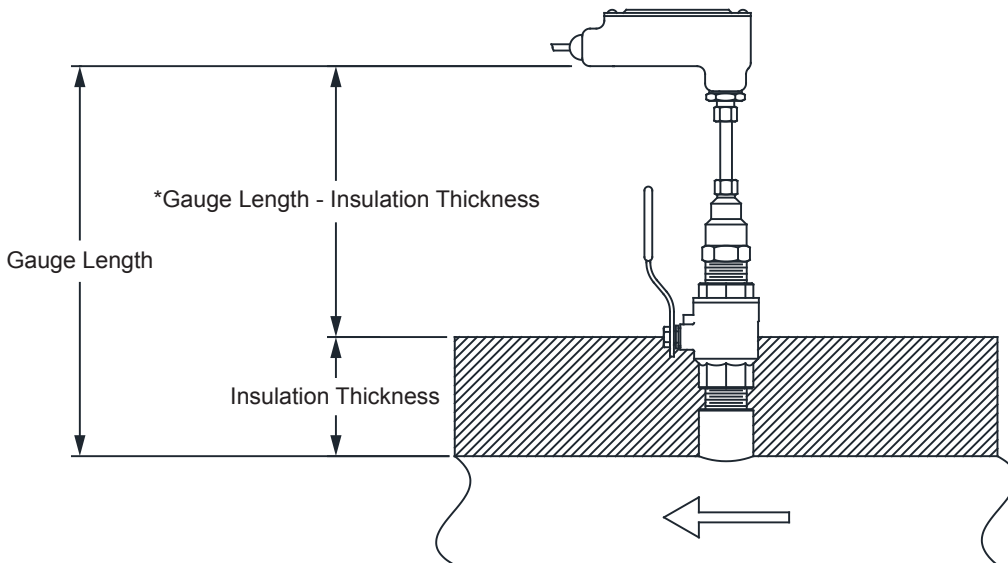

3.5 REMOVAL OF THE INSERTION METER



WARNING

Remember, the meter may be under high pressure. And while removal of the meter is basically the reverse of the insertion procedure detailed above, care must be taken to ensure that the meter is supported against the pipe pressure before the position clamping nut is loosened. Failure to do this will allow the pressure to suddenly and rapidly force the meter from the pipe causing serious injury.



WARNING

Prior to removal of the meter, make sure that you are standing on a secure platform and have both hands available to manipulate the flow meter.

First support the flow meter against the pipe pressure by holding the electronics enclosure firmly in hand BEFORE loosening the position clamping nut. The effort required is the same as that required for insertion of the meter and should be calculated according to the formula in section 3.4 covering insertion of the meter. This effort will be 0.11 times the pipe pressure. **If your footing is not secure, or if your ability to hold the meter is limited for any reason, DO NOT loosen the clamping nut.**

SLOWLY loosen the position clamping nut and **carefully and slowly** allow the pressure to force the meter out of the pipe. This is not at all difficult, but you must not let go of the meter until it is fully withdrawn into the hot tap adapter. **DO NOT attempt to close the ball valve** until you are certain that the turbine assembly is fully withdrawn into the hot tap adapter.

A common cause of damage to meters comes from accidentally closing the valve and crushing the turbine assembly. To avoid this, gently rotate the meter back and forth by using the electronics enclosure, while closing the valve slowly. If the valve touches any part of the meter, you will feel it as you are moving the meter. If the valve touches anything, it means the meter is not fully withdrawn. Usually a gentle twisting motion while withdrawing the meter will clear any obstruction and permit the meter to withdraw completely. (Excessive build-up on the stem may require the hot tap 'O' ring to be lubricated with silicone.)

Continue to hold the meter in place after the valve is completely closed to prevent the turbine assembly from slipping back into the valve body. Slowly unscrew the hot tap adapter from the valve. Once the adapter is loosened, allow pressure to vent from inside the hot tap adapter before removing it from the valve. There will be a small amount of water inside the hot tap adapter. A small container can be held under the valve to catch any spilled water. Once the meter has been moved to its new depth, tighten the position clamping nut. Next, place several turns of electrical tape around the stem just above the clamping nut so that at a later time, when the meter is removed for service, it can be easily replaced at the same depth.

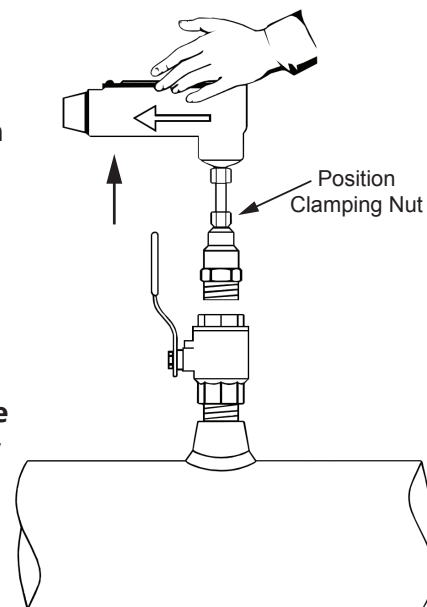

WARNING

In hot water systems, even a small amount of water can cause serious personal injury. Use extra caution when working with hot water meters.

3.6 INLINE METER STRAIGHT RUN REQUIREMENTS AND MECHANICAL INSTALLATION

Locating the meter

Install process connections (sweat or threaded end pieces) making certain to leave adequate straight unobstructed pipe runs upstream and downstream of the meter location.

1. The minimum upstream straight run should be at least 10 diameters and the downstream straight run should be at least 5 diameters in length.
2. If more than 15 diameters of straight run are available at the installation site, the excess straight run should be upstream of the meter location.
3. Please note that ONICON strongly recommends the use of strainers upstream of the meter location.
4. ONICON also recommends the installation of isolation valves and a bypass loop to accommodate servicing the meter.

TYPICAL INLINE METER INSTALLATION

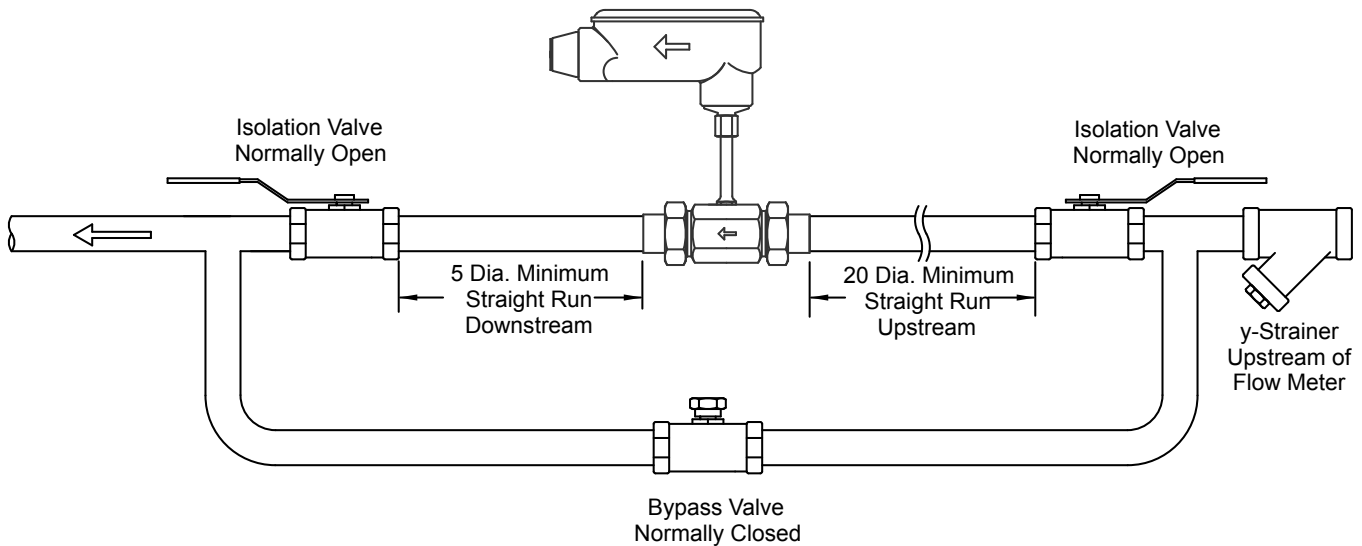

Installing the meter body

1. Make sure the unions are free of nicks or scratches on either end of the flow meter body and on the process connections.
2. Spray the union faces with a silicone spray or apply a thin coat of beeswax to enhance seating. Do not use paste thread sealant on union faces.
3. Recommended torques for union seal: 70 ft/lbs minimum
4. Make sure alignment of pipe does not put lateral stress on either joint.

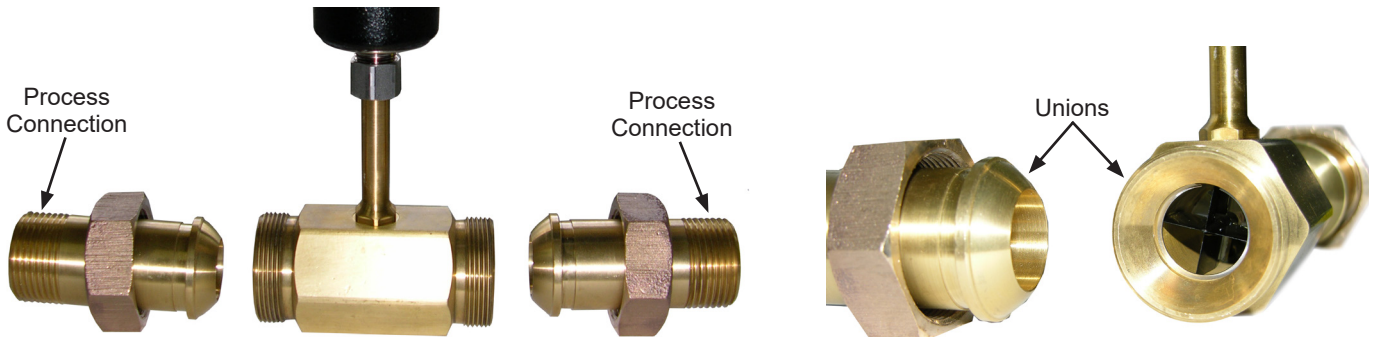

3.7 WIRING CONNECTIONS

Make connections to the 10' cable, which is supplied by ONICON and is pre-wired to the circuit board.



CAUTION

Do not attempt to make any connections inside the electronics enclosure, or to remove factory installed cable, strain relief or conduit fitting. Damage resulting from these actions will not be covered under warranty.

The most common cause of electronic failures are mis-wired connections. If you are adding additional cable, please record any substitution of wire colors. If additional cable is purchased from ONICON, the color code can be maintained. Cable from other sources will most likely have a different set of colors. Please refer to Appendix A for wiring diagrams and factory color codes.

Only qualified service personnel should make connections between the flow meter and the user's external equipment. Any misapplication of power and/or ground can result in improper operation or damage to the flow meter circuitry, and to any externally connected equipment.

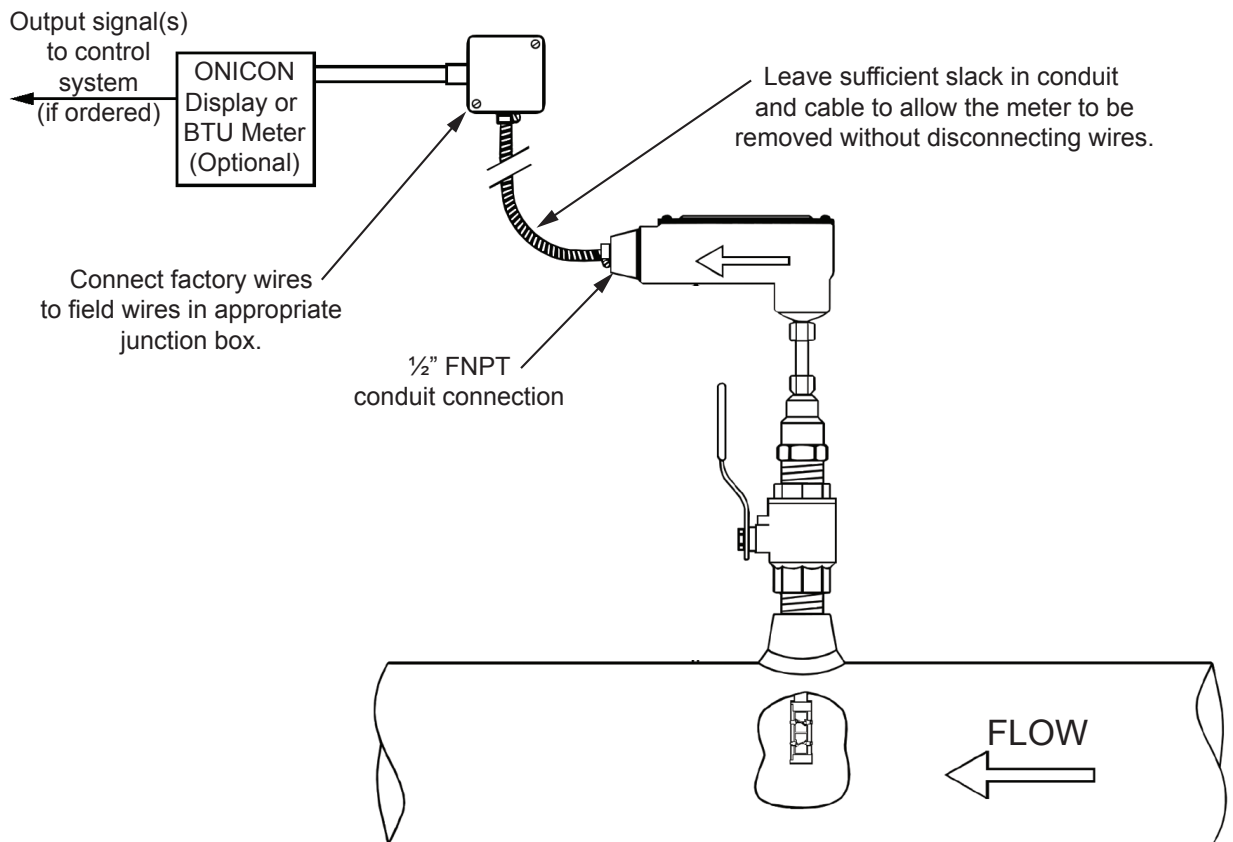

SECTION 4.0: STARTUP & COMMISSIONING FOR ONICON TURBINE FLOW METERS

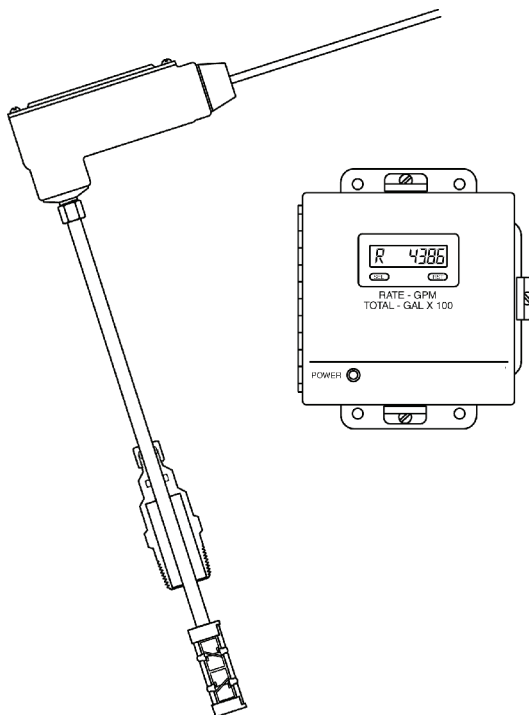

4.1 HELPFUL HINTS FOR START-UP AND COMMISSIONING

Step-by-step procedures and companion worksheets are located on the next four pages. Please read all installation instructions carefully before proceeding with start-up and commissioning.

1. ONICON Insertion Turbine Flow Meters are individually configured for a particular application. Be sure to verify the pipe size and location. Use the Smart Turbine Meter Configuration Utility to change configural pipe size.
2. The electronic sensing systems will not work in air. Blowing on the turbine(s) will not produce a signal. You can test the meter by holding the turbines under a faucet or carefully moving it back and forth in a bucket of water.
3. When measuring analog output signals, remember that current (mA) must be measured in series, while voltage is measured in parallel. If the 4-20 mA signal is already connected to a control system, you must break the connection and measure the signal in series.
4. When measuring frequency outputs in Hertz, take your multimeter out of "auto-range mode" and manually set the range for a voltage level above 15 VDC. This will prevent false readings when no turbine signal is present.
5. All wiring connections should be made at the end of the factory cable. Do not attempt to remove the factory installed cable or change the orientation of the electronics enclosure.
6. Never connect power to analog or frequency output signal wires. ONICON turbine flow meters are not "loop-powered" devices.
7. Allow up to 45 seconds for signals to stabilize following power up.

4.2 INSERTION METER START-UP AND COMMISSIONING

Please read the entire procedure carefully before proceeding. Wiring diagrams are located in the appendix. A worksheet for checking off the following steps and recording measured values is located on the following page.

1	Confirm meter location and adequate straight pipe run to achieve desired results.	Is the meter located in the correct location as required by the plans? Compare actual straight pipe upstream and downstream of the meter location to recommended distances identified in the installation manual. Note: The manual is very conservative, assuming worst-case pipe obstructions. Contact ONICON to discuss specifics of your application. If straight pipe run is very short, consult factory PRIOR to installing a single turbine meter to discuss possibility of upgrade to a dual turbine meter.
2	Confirm pipe size.	Confirm that the meter is programmed for the pipe size in which it is installed. When in doubt, measure the circumference of the pipe. Pipe O.D. = (circumference / 3.14) – (insulation thickness x 2). Use the Smart Turbine Meter Configuration Utility to change the meter’s pipe size.
3	Confirm insertion depth and orientation.	Ensure the meter is inserted to the correct depth shown in the Smart Turbine Meter Configuration Utility and that the electronics enclosure is parallel with the pipe, with the arrow in the direction of flow.
4	Confirm control system programming.	Confirm that the control system input point is properly configured for the analog range (or digital pulse factor) identified in the Smart Turbine Meter Configuration Utility or calibration certificate.
5	Confirm connection to correct ONICON display or BTU meter (if ordered).	Confirm that the flow meter serial number matches the ONICON display or BTU meter serial number (when ordered together).
6	Verify wiring before connecting power.	Prior to connecting the power, verify that the wiring is correct as shown in this manual (and/or with the additional wiring diagram provided with ONICON display or BTU meter.) If in doubt, call ONICON for assistance before proceeding further.
7	Confirm correct supply voltage.	Verify that 24 (+/- 4) V is available. Serial Numbers 115692 and later can accept 24 V DC or AC, but earlier meters required 24 VDC. Note: ONICON display module(s) or BTU meter(s) provide 24 VDC to the flow meter. ONICON display modules and BTU meters are typically powered by 120 VAC; however, low voltage versions are also available.
8	Connect power.	Wait approximately 45 seconds after power-on before proceeding further.
The following steps require flow in the pipe. Flow signal readings should be taken while holding the flow rate constant if possible; otherwise, take the various output readings as quickly as possible.		
9	Measure and record frequency output(s)	The average frequency output signal is a 0-15 VDC pulsed output ranging up to 500 Hz and must be measured with a frequency counter or oscilloscope. Measure DC frequency (Hz) from GREEN(+) to BLACK(-). Also measure DC volts on same wires. Five to seven VDC is normal for a spinning turbine, 0 or 14+ VDC indicates a stopped turbine. (A reading of 1 to 4 VDC could indicate a problem) $\text{GPM} = \frac{\text{Frequency in Hz} \times 60}{\text{Meter Factor in ppg}}$ (Refer to certificate of calibration or Smart Turbine Meter Configuration Utility for meter factor.) For dual turbine models, also measure and record the top and bottom turbine signals. TOP: WHITE(+) to BLACK(-) BOTTOM: ORANGE(+) to BLACK(-)
10	Measure and record analog or digital outputs. Current Output: Voltage (0-10V) Output: Scaled Output:	Refer to flow meter wiring diagram for wire colors for the various outputs available based on your particular flow meter model. Use the following formulas to calculate flow rate from measured analog signals: $\text{GPM} = \frac{(\text{measured current in mA} - 4) \times \text{Full Scale Analog Flow Rate}}{16}$ $\text{GPM} = \frac{\text{measured DC volts} \times \text{Full Scale Analog Flow Rate}}{10}$ Each contact closure = unit volume identified as “Scaled Output Multiplier” in the Smart Turbine Meter Configuration Utility (measure and record time interval between contact closures.)
11	Compare various output signals to each other and to the flow rate displayed by the control system.	The top and bottom turbine frequencies (dual) should ideally be within about 20% of each other and their average should equal the average frequency output. Compare the flow rates calculated in STEPS 9 and 10 to each other and to the flow rate indicated by the control system. Refer to troubleshooting guide when readings are inconsistent.
End of standard start-up and commissioning. Please contact ONICON at (727) 447-6140 with any questions.		

4.3 INSERTION METER START-UP AND COMMISSIONING WORKSHEET

Please read all installation instructions carefully prior to proceeding with these steps. Wiring diagrams are located in the appendix. Use the following worksheet for checking off the commissioning steps and recording measured values:

STEP	TEST / MEASUREMENT	S/N: _____	S/N: _____	S/N: _____	S/N: _____
1	Meter location				
2	Confirm pipe size				
3	Insertion depth and orientation				
4	Control system programming				
5	Match display or BTU meter serial# (if ordered)				
6	Signal connections verified				
7	Supply voltage verified				
8	Connect power				
The following steps require flow in the pipe. Flow signal readings should be taken while holding the flow rate constant if possible; otherwise, take the various output readings as quickly as possible.					
9	Frequency output(s): Avg = green, Top = white Bottom = orange				
	Avg freq. (HZ): _____ Hz	_____ Hz	_____ Hz	_____ Hz	_____ Hz
	Avg freq. (VDC): _____ VDC	_____ VDC	_____ VDC	_____ VDC	_____ VDC
	Top turbine (HZ): _____ Hz	_____ Hz	_____ Hz	_____ Hz	_____ Hz
	Top turbine (VDC): _____ VDC	_____ VDC	_____ VDC	_____ VDC	_____ VDC
	Bottom turbine (HZ): _____ Hz	_____ Hz	_____ Hz	_____ Hz	_____ Hz
	Bottom turbine (VDC): _____ VDC	_____ VDC	_____ VDC	_____ VDC	_____ VDC
	Calculated flow rate: _____ GPM	_____ GPM	_____ GPM	_____ GPM	_____ GPM
10	Analog or digital outputs				
	4-20 mA signal: _____ MA	_____ MA	_____ MA	_____ MA	_____ MA
	0-10 V signal: _____ VDC	_____ VDC	_____ VDC	_____ VDC	_____ VDC
	Scaled output time interval _____	_____	_____	_____	_____
	Calculated flow rate: _____ GPM	_____ GPM	_____ GPM	_____ GPM	_____ GPM
11	Flow rate displayed by control system	_____ GPM	_____ GPM	_____ GPM	_____ GPM

4.4 INLINE METER START-UP AND COMMISSIONING

Please read the entire procedure carefully before proceeding. Wiring diagrams are located in the appendix. A worksheet for checking off the following steps and recording measured values is located on the following page.

1	Confirm meter location and adequate straight pipe run to achieve desired results.	Is the meter located in the correct location as required by the plans? Compare actual straight pipe upstream and downstream of the meter location to recommended distances identified in the installation manual. If straight pipe run is very short, consult ONICON PRIOR to installing the meter.
2	Confirm control system programming.	Confirm that the control system input point is properly configured for the analog range (or digital pulse factor) identified in the Smart Turbine Meter Configuration Utility or calibration certificate.
3	Confirm connection to correct ONICON display or BTU Meter (if ordered).	Confirm that the flow meter serial number matches the ONICON display or BTU meter serial number (when ordered together).
4	Verify wiring before connecting power.	Prior to connecting the power, verify that the wiring is correct as shown in this manual (and/or with the additional wiring diagram provided with ONICON display or BTU meter.) If in doubt, call ONICON for assistance before proceeding further.
5	Confirm correct supply voltage.	Verify that 24 (+/- 4) V is available. Serial Numbers 115692 and later can accept 24 VDC or AC, but earlier meters required 24 VDC. Note: ONICON display module(s) or BTU meter(s) provide 24 VDC to the flow meter. ONICON display module(s) and BTU meter(s) are typically powered by 120 VAC; however, low voltage versions are also available.
6	Connect power.	Wait approximately 45 seconds after power-on before proceeding further.
The following steps require flow in the pipe. Flow signal readings should be taken while holding the flow rate constant if possible; otherwise, take the various output readings as quickly as possible.		
7	Measure and record frequency output(s):	The frequency output signal is a 0-15 VDC pulsed output ranging up to 500 Hz and must be measured with a frequency counter or oscilloscope. Measure DC frequency (Hz) from GREEN(+) to BLACK(-). Also measure DC volts on same wires. Five to seven VDC is normal for a spinning turbine, 0 or 14+ VDC indicates a stopped turbine. (1 to 4 VDC could indicate a problem) $\text{GPM} = \frac{\text{Frequency in Hz} \times 60}{\text{Meter Factor in ppg}}$ (Refer to certificate of calibration of Smart Turbine Meter Configuration Utility for meter factor)
8	Measure and record analog or digital outputs. Current Output: Voltage Output: Scaled Output:	Refer to flow meter wiring diagram for wire colors for the various outputs available based on your particular flow meter model. Use the following formulas to calculate flow rate from measured analog signals: $\text{GPM} = \frac{(\text{measured current in mA} - 4)}{16} \times \text{Full Scale Analog Flow Rate}$ $\text{GPM} = \frac{\text{measured DC volts}}{10} \times \text{Full Scale Analog Flow Rate}$ Each contact closure = unit volume identified as "Scaled Output Multiplier" in the Smart Turbine Meter Configuration Utility (measure and record time interval between contact closures.)
9	Compare various output signals to each other and to the flow rate displayed by the control system.	Compare the flow rates calculated in STEPS 7 and 8 to each other and to the flow rate indicated by the control system. Refer to troubleshooting guide when readings are inconsistent.
End of standard start-up and commissioning. Please contact ONICON at (727) 447-6140 with any questions.		

4.5 INLINE METER START-UP AND COMMISSIONING WORKSHEET

Please read all installation instructions carefully prior to proceeding with these steps. Wiring diagrams are located in the appendix. Use the following worksheet for checking off the commissioning steps and recording measured values:

STEP	TEST / MEASUREMENT	S/N: _____	S/N: _____	S/N: _____	S/N: _____
1	Meter location				
2	Control system programming				
3	Match display or BTU meter serial# (if ordered)				
4	Signal connections verified				
5	Supply voltage verified				
6	Connect power				
The following steps require flow in the pipe. Flow signal readings should be taken while holding the flow rate constant if possible; otherwise, take the various output readings as quickly as possible.					
7	Frequency output(s): Avg = green, Top = white Bottom = orange				
	Avg Freq. (HZ): _____ Hz	_____ Hz	_____ Hz	_____ Hz	_____ Hz
	Avg Freq. (VDC): _____ VDC	_____ VDC	_____ VDC	_____ VDC	_____ VDC
	Calculated Flow Rate: _____ GPM	_____ GPM	_____ GPM	_____ GPM	_____ GPM
8	Analog or digital outputs				
	4-20 mA signal: _____ MA	_____ MA	_____ MA	_____ MA	_____ MA
	0-10 V signal: _____ VDC	_____ VDC	_____ VDC	_____ VDC	_____ VDC
	Scaled output time interval	_____	_____	_____	_____
	Calculated Flow Rate: _____ GPM	_____ GPM	_____ GPM	_____ GPM	_____ GPM
9	Flow rate displayed by control system	_____ GPM	_____ GPM	_____ GPM	_____ GPM

4.6 TROUBLESHOOTING GUIDE

NOTE: Also refer to the START-UP and COMMISSIONING GUIDE located on the preceding pages.

REPORTED PROBLEM	POSSIBLE SOLUTIONS
No signal	Verify that meter is inserted correctly into the pipe. <ul style="list-style-type: none"> • Verify that the electronics enclosure is parallel with the pipe. • Verify 24 V supply voltage. • Verify correct wiring to control system (see wiring diagram). • Check turbine(s) for debris. • Check diagnostics in Smart Turbine Meter Configuration Utility to see if you are getting turbine pulses. LED lights inside meter enclosure will also flash if the turbines are spinning.
Reading is too high or too low	<ul style="list-style-type: none"> • Confirm that there is adequate straight pipe run upstream of the meter. Verify pipe size. Contact factory if pipe size is different from calibration tag. • Verify that meter is inserted correctly into the pipe. • Verify that the electronics enclosure is parallel with the pipe. • Verify correct wiring to control system (see wiring diagram). • Confirm that output signals agree with each other (frequency vs. analog, etc.) • Confirm that control system is programmed for correct flow range or scale factor. • Check turbine(s) for debris. • Check pipe sized programming in Smart Turbine Meter Configuration Utility.
Analog signal seems high or low and does not correspond to frequency output	Check for ground loop or offset voltage: <ul style="list-style-type: none"> • Disconnect analog signal input to control system and measure analog outputs directly from the flow meter. • Re-connect signal input to control system and measure the analog signals again. • Any difference between these readings indicates a potential ground loop or offset voltage. • Please contact ONICON for further assistance.
Control system displays flow rate, but no flow rate indication on local display module or BTU meter	<ul style="list-style-type: none"> • Verify that all wires from flow meter were connected to the display module or BTU meter. • The frequency output wire (green) must be connected for any ONICON display or BTU meter.

For technical assistance, contact ONICON at (727) 447-6140.

SECTION 5.0: FIELD PROGRAMMING & DIAGNOSTICS

The Microprocessor Based Turbine Flow Meter enables the end-user with the ability to change various parameters which affect the meter's calibration, as well as provide diagnostic data which can be useful in determining if the meter has/had a problem.

These parameters and diagnostic data can be accessed via the Smart Turbine Meter Configuration Utility running on a PC interfaced with the meter's Micro B USB port inside the electronics enclosure.

Some of the calibration parameters which can be changed include:

- Set switch output to either Scaled Pulse or Alarm
- Pipe Size
- Analog output range and engineering units
- Scaled pulse scaling and engineering units
- Frequency output scaling

Some of the diagnostic data which is available:

- Top, Bottom, and Average turbine pulses
- Total Top, Bottom, and Average turbine pulses over the life of the meter
- Run time
- User-resettable totalizer
- Current frequency and analog output values to compare against control system

The Smart Turbine Meter Configuration Utility and the instructions for its use can be downloaded at www.onicon.com/TurbineMeter_Configuration.html.

5.1 DIAGNOSTIC LEDs

The Microprocessor Based Turbine Meter features diagnostic LEDs, inside the electronics enclosure on the meter's electronics, which can be used to determine the status of the meter without the use of a multimeter.

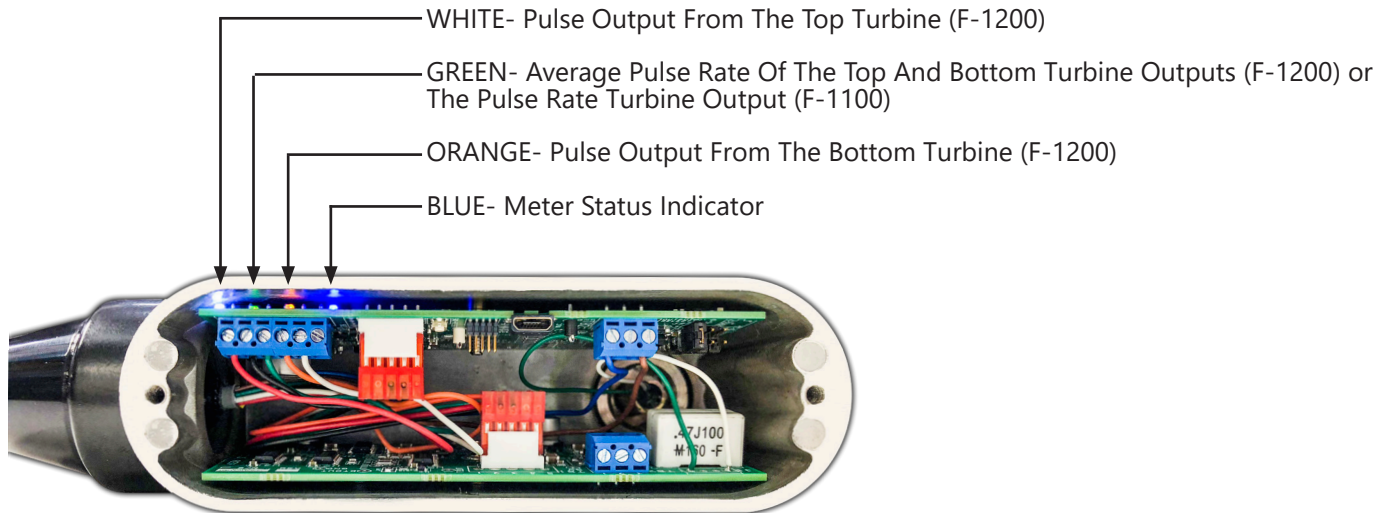

How to read the blinking pattern:

Status LED (BLUE)

- Normal Status – 500ms ON, 500ms OFF
- Warning Status – 2 rapid blinks, then 500ms OFF
- Alarm Status – 3 rapid blinks, then 500ms OFF
- Error Status – 4 rapid blinks, then 500ms OFF

IMPORTANT NOTE

Connect the turbine meter to the Smart Turbine Meter Configuration Utility if receiving specific warning/ alarm/ error message to get additional information.

Top Turbine LED (WHITE)

- This LED will blink at a rate proportional to the speed of the top turbine signal (F-1200 only).
- If this light is not blinking, yet the green and orange LEDs are, this could mean the top turbine is bound or damaged. Remove the meter to inspect the top turbine.

Average Turbine LED (GREEN)

- This LED will blink at a rate proportional to the speed of the average turbine signal.
- For dual turbine meters, the average turbine signal is the average of the top and bottom turbine speed.
- For single turbine meters, the average turbine signal is the speed of the single turbine.

Bottom Turbine LED (ORANGE)

- This LED will blink at a rate proportional to the speed of the bottom turbine signal (F-1200 only).
- If this light is not blinking, yet the green and white LEDs are, this could mean the bottom turbine is bound or damaged. Remove the meter to inspect the bottom turbine.

APPENDIX A

User Connections and Internal Wiring Diagrams

FLOW METER WIRING INFORMATION

User Connections for Models with Frequency Output

Models: F-1XXX-00

F-1XXX-00		Wiring Information	
		WIRE COLOR CODE	NOTES
√	RED	(+) 24 ± 4 V AC/DC supply voltage	Connect to power supply positive
√	BLACK	(-) Common ground (Common with pipe ground)	Connect to power supply negative
√	GREEN	(+) Frequency output signal: 0-15 V peak pulse	Max Hz can be set in Smart Turbine Meter Configuration Utility
SCALED PULSE OUTPUT			
√	ORANGE	Dry Contact	Scaled Pulse Output
√	WHITE	Dry Contact	

F-1XXX-00 WIRING DIAGRAM

Flow Meter Connections to ONICON Display or BTU Meter

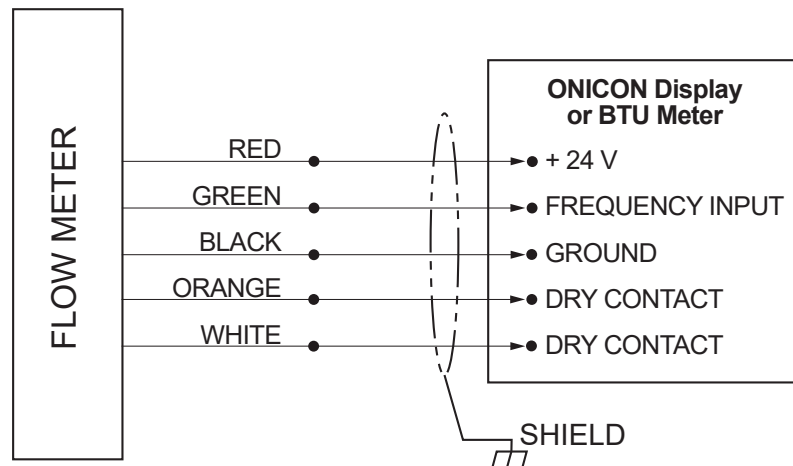

NOTES:

1. Black wire is common with the pipe (typically earth ground).
2. For ONICON display module or BTU meter, connect all wires provided. Refer to wiring diagram provided with display or BTU meter

FLOW METER WIRING INFORMATION

User Connections for Models with Frequency Output

Models: F-1XXX-00

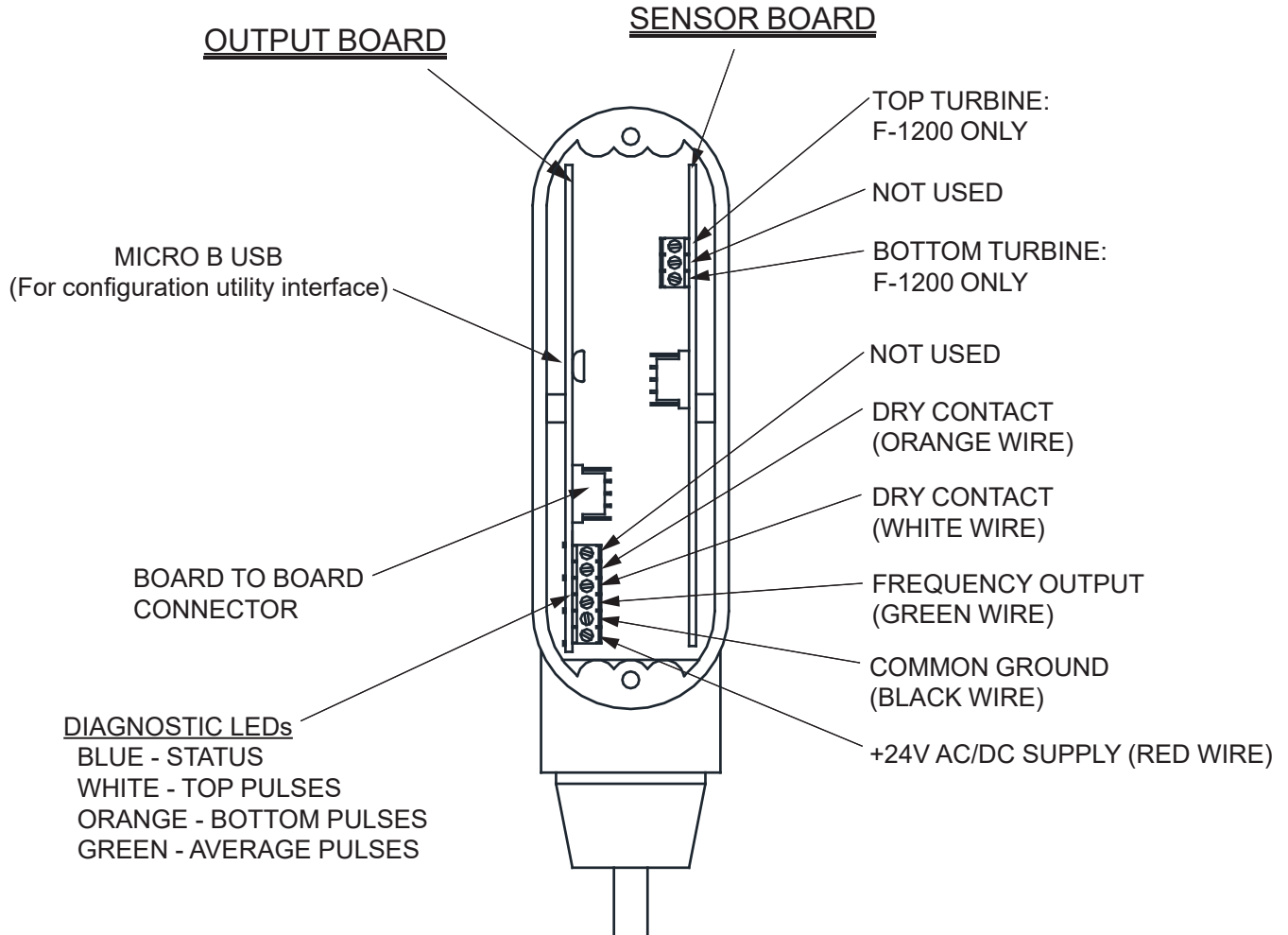

NOTES:

FLOW METER WIRING INFORMATION

User Connections for Models with Analog Output
 Models: F-1XXX-10

Wiring Information			
F-1XXX-10	WIRE COLOR CODE		NOTES
√	RED	(+) 24 ± 4 V AC/DC supply voltage	Connect to power supply positive
√	BLACK	(-) Common ground (Common with pipe ground)	Connect to power supply negative & analog input ground
√	GREEN	(+) Frequency output signal: 0-15 V peak pulse	Required when meter is connected to local display or Btu meter
√	BLUE	(+) Analog signal	Jumper selectable (4-20 mA / 0-10 V / 0-5 V)
√	BROWN	(-) Analog signal	
SCALED PULSE OUTPUT			
√	ORANGE	Dry Contact	Scaled Pulse Output
√	WHITE	Dry Contact	

F-1XXX-10 WIRING DIAGRAM

Flow Meter Connections to ONICON Display or BTU Meter

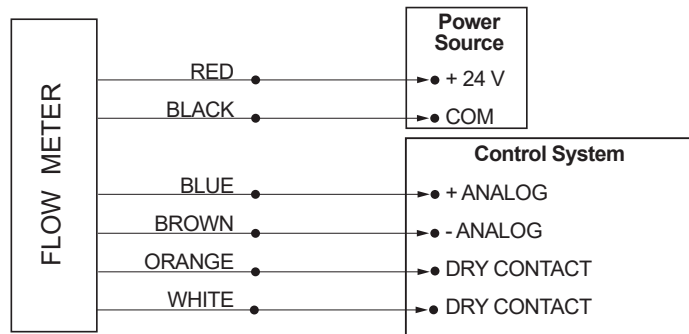

NOTES:

1. Black wire is common with the pipe (typically earth ground).
2. For ONICON display module or BTU meter, connect all wires provided. Refer to wiring diagram provided with display or BTU meter



CAUTION

This is NOT a "loop-powered" instrument. DO NOT connect power to any of the signal output wires (blue, brown, green, orange or white)

FLOW METER WIRING INFORMATION

User Connections for Models with Analog Output

Models: F-1XXX-10

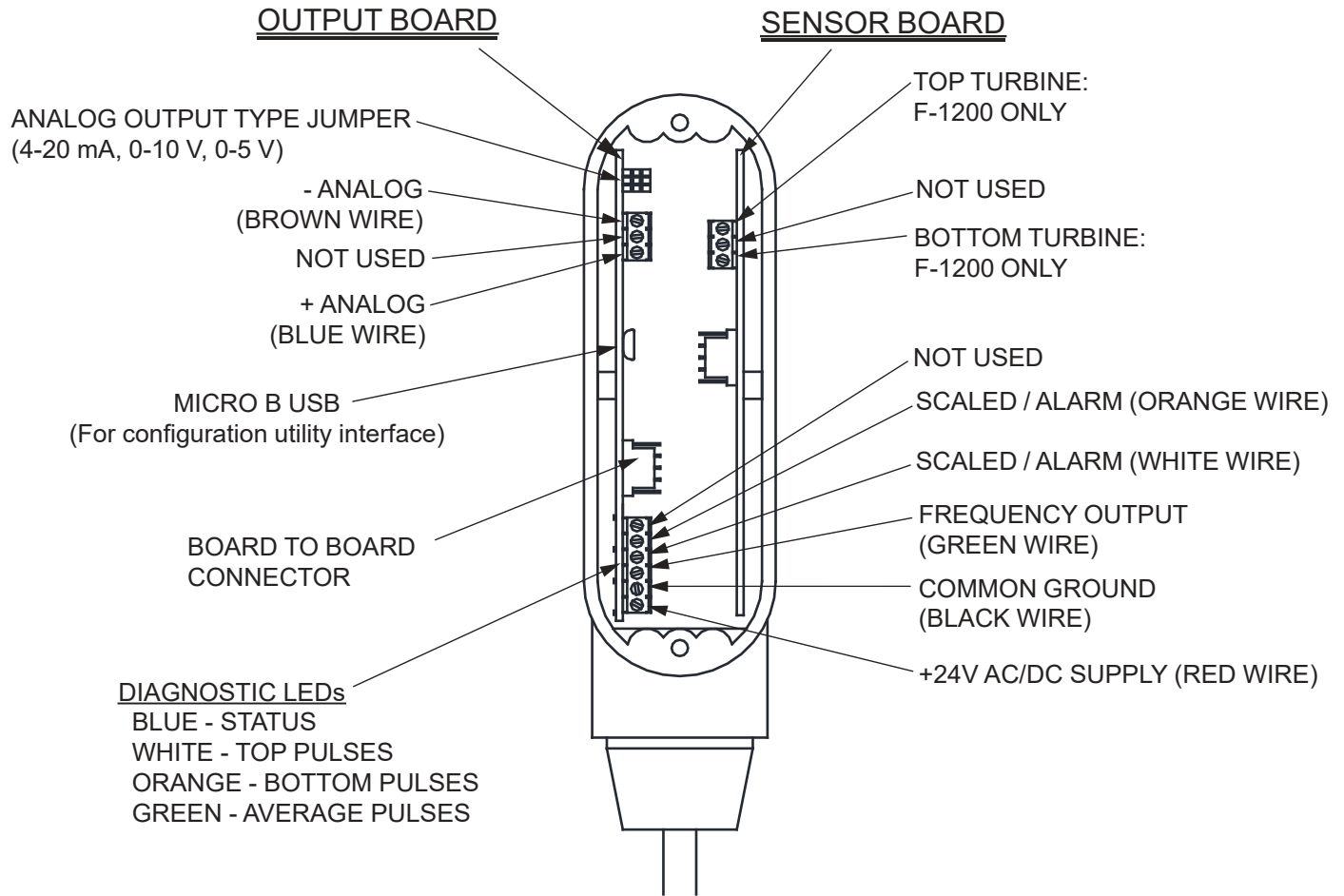

NOTES:

FLOW METER WIRING INFORMATION

User Connections for Models with Isolated Analog Output

Models: F-1XXX-11

F-1XXX-11 Wiring Information			
	WIRE COLOR CODE		NOTES
✓	RED	(+) 24 ± 4 V AC/DC supply voltage	Connect to power supply positive
✓	BLACK	(-) Common ground (Common with pipe ground)	Connect to power supply negative
✓	GREEN	(+) Frequency output signal: 0-15 V peak pulse	Required when meter is connected to local display or BTU meter
✓	BLUE	(+) Analog signal	Jumper selectable (4-20 mA / 0-10 V / 0-5 V)
✓	BROWN	(-) Analog signal	
SCALED PULSE OUTPUT			
✓	ORANGE	Dry Contact	Scaled Pulse Output
✓	WHITE	Dry Contact	

F-1XXX-11 WIRING DIAGRAM

Flow Meter Connections to ONICON Display or BTU Meter

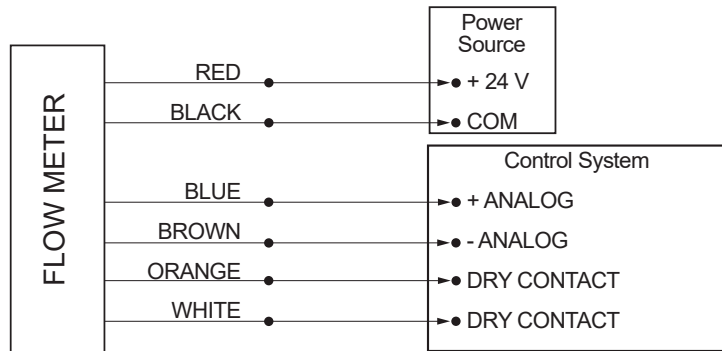

NOTES:

1. Black wire is common with the pipe (typically earth ground).
2. For ONICON display module or BTU meter, connect all wires provided. Refer to wiring diagram provided with display or BTU meter



CAUTION

This is NOT a "loop-powered" instrument. DO NOT connect power to any of the signal output wires (blue, brown, green, orange or white)

FLOW METER WIRING INFORMATION

User Connections for Models with Isolated Analog Output

Models: F-1XXX-11

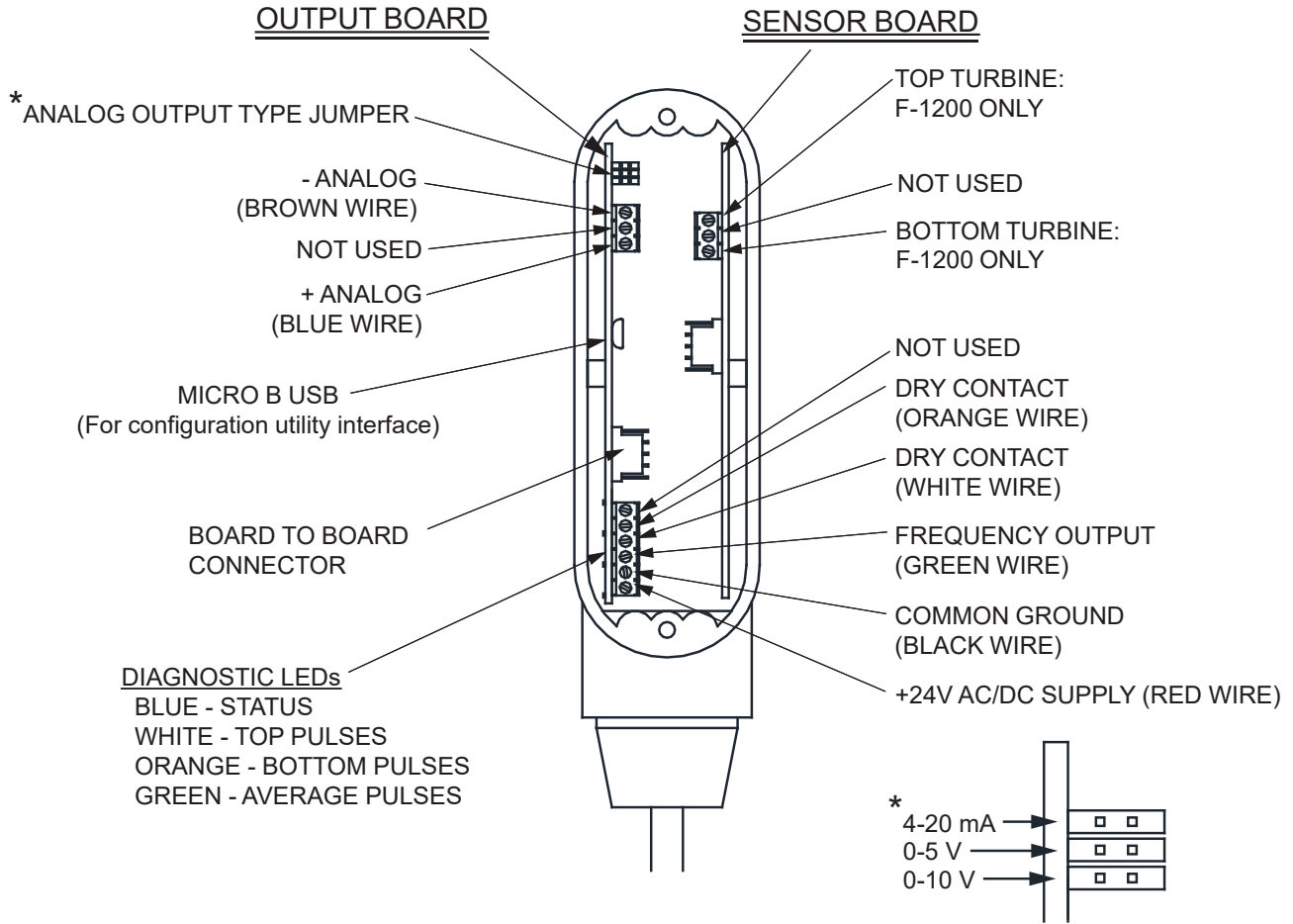

NOTES:

APPENDIX B

Installation Hardware Instructions

Installation Hardware Instructions
Dry Tap Installation Kit for Welded Steel Pipe
 For F-1000 Series, F-3500 Series Insertion Flow Meters

For Use With Kits: INSTL0001-FMD, INSTL01DW-FMD, INSTL0005-FMD, INSTL0018-FMD

This kit must be installed prior to filling the system, or into a section of pipe that is isolated from pressure and flow. Once installed, this kit allows for insertion and removal of the flow meter without a system shutdown.

Directions:

1. Identify an appropriate location for the flow meter.
2. Weld the branch outlet onto the pipe.
3. Drill a 1" (minimum) access hole in the pipe, centered in the branch outlet.
4. Install the close nipple and ball valve as shown below. Use a paste type thread sealant or use Teflon® tape. **DO NOT** use Teflon® tape for F-1100 & F-1200 Series.
5. Flush and fill the system prior to installing the meter.

NOTE: Before installing the flow meter, read the entire installation manual.

IMPORTANT NOTE
 ONICON insertion flow meters are precision measuring devices that must be installed according to the instructions contained in this document in order to maintain their accuracy and reliability. Failure to follow these instructions will result in erratic operation and reduced accuracy.

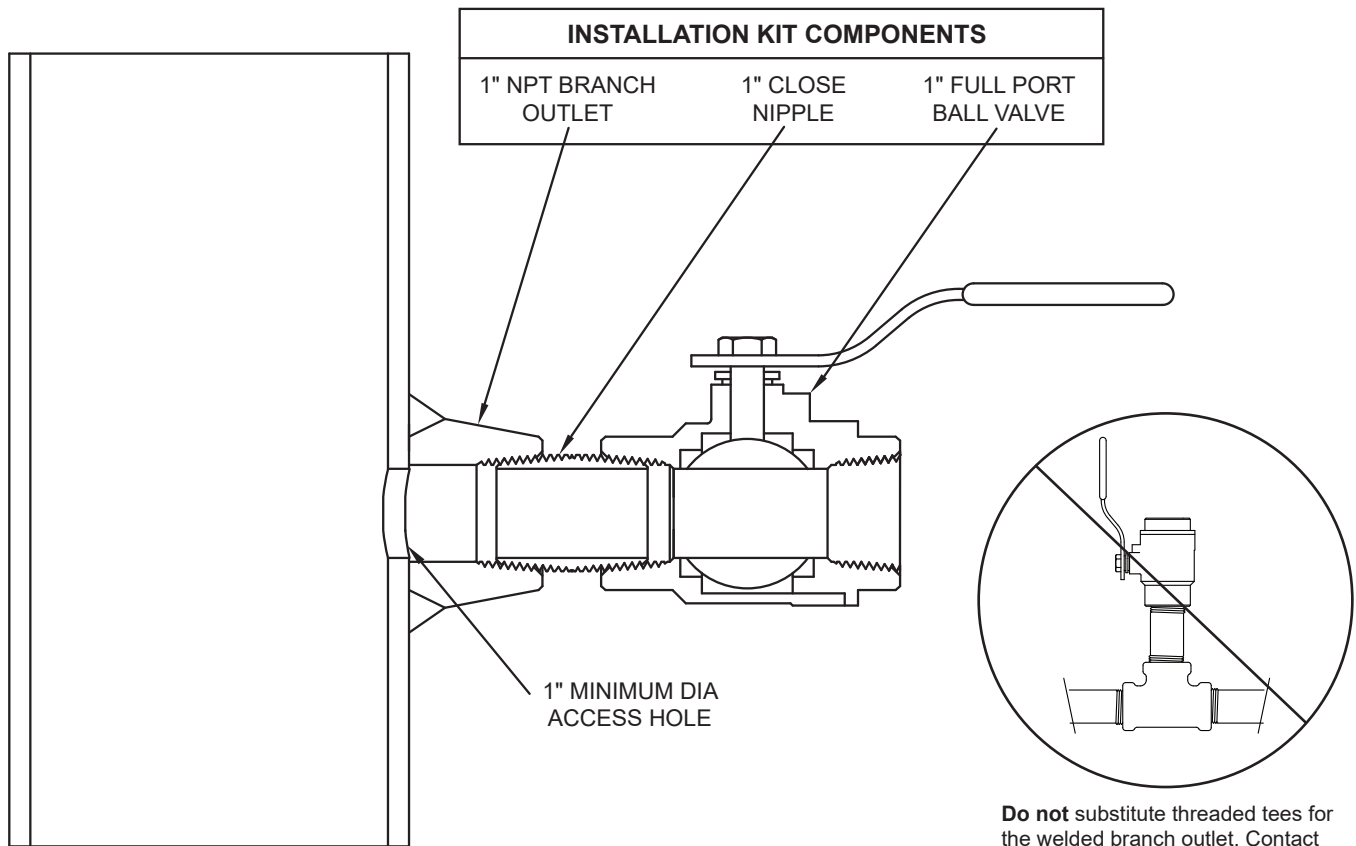

Dry Tap Installation Kit for 1¼ - 2½" Threaded Pipe
 For F-1000 Series & F-3500 Series Insertion Flow Meters

For Use With Kits: INSTL0007-FMD, INSTL0008-FMD

This kit must be installed prior to filling the system, or into a section of pipe that is isolated from pressure and flow. Once installed, this kit allows for insertion and removal of the flow meter without a system shutdown.

Directions:

1. Identify an appropriate location for the flow meter.
2. Install the threaded pipe nipple, close nipple and ball valve as shown below. Use a paste type thread sealant. **DO NOT** use Teflon® tape
3. Flush and fill the system prior to installing the meter.

NOTE: Before installing the flow meter, read the entire installation manual.

IMPORTANT NOTE
 ONICON insertion flow meters are precision measuring devices that must be installed according to the instructions contained in this document in order to maintain their accuracy and reliability. Failure to follow these instructions will result in erratic operation and reduced accuracy.

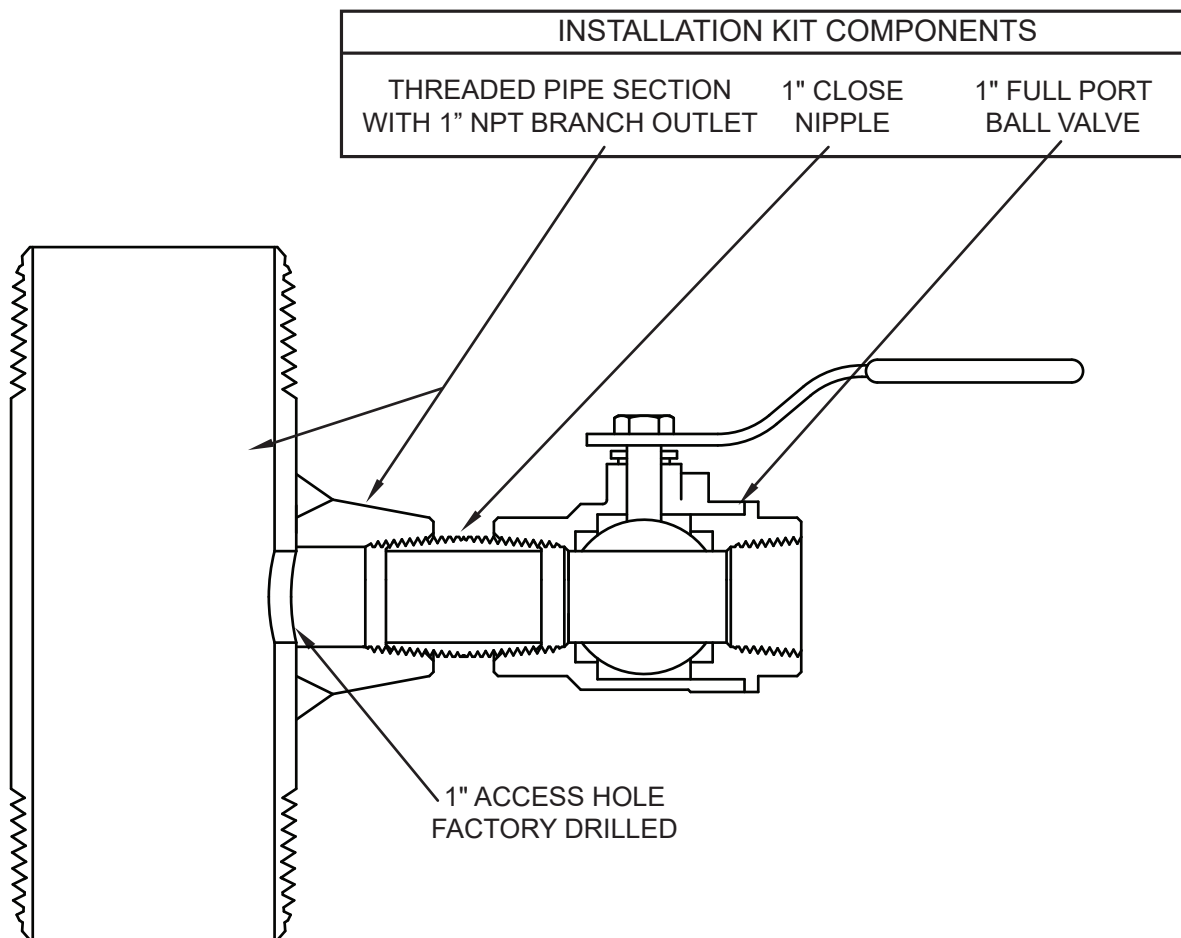

Dry Tap Installation Kit for Copper Tube (Components Comply with NSF61)
 For F-1000 & F-3500 Series Insertion Flow Meters

For Use With Kits: INSTL0003-FMD, INSTL0004-FMD, INSTL0009-FMD

This kit must be installed prior to filling the system, or into a section of pipe that is isolated from pressure and flow. Once installed, this kit allows for insertion and removal of the flow meter without a system shutdown.

Directions:

1. Identify an appropriate location for the flow meter.
2. Solder or braze the copper tee and adapter provided.
3. Install the ball valve as shown below. Use a paste type thread sealant or use Teflon® tape. **DO NOT** use Teflon® tape for F-1100 & F-1200 Series.
4. Flush and fill the system prior to installing the meter.

NOTE: Before installing the flow meter, read the entire installation manual.

IMPORTANT NOTE
 ONICON insertion flow meters are precision measuring devices that must be installed according to the instructions contained in this document in order to maintain their accuracy and reliability. Failure to follow these instructions will result in erratic operation and reduced accuracy.

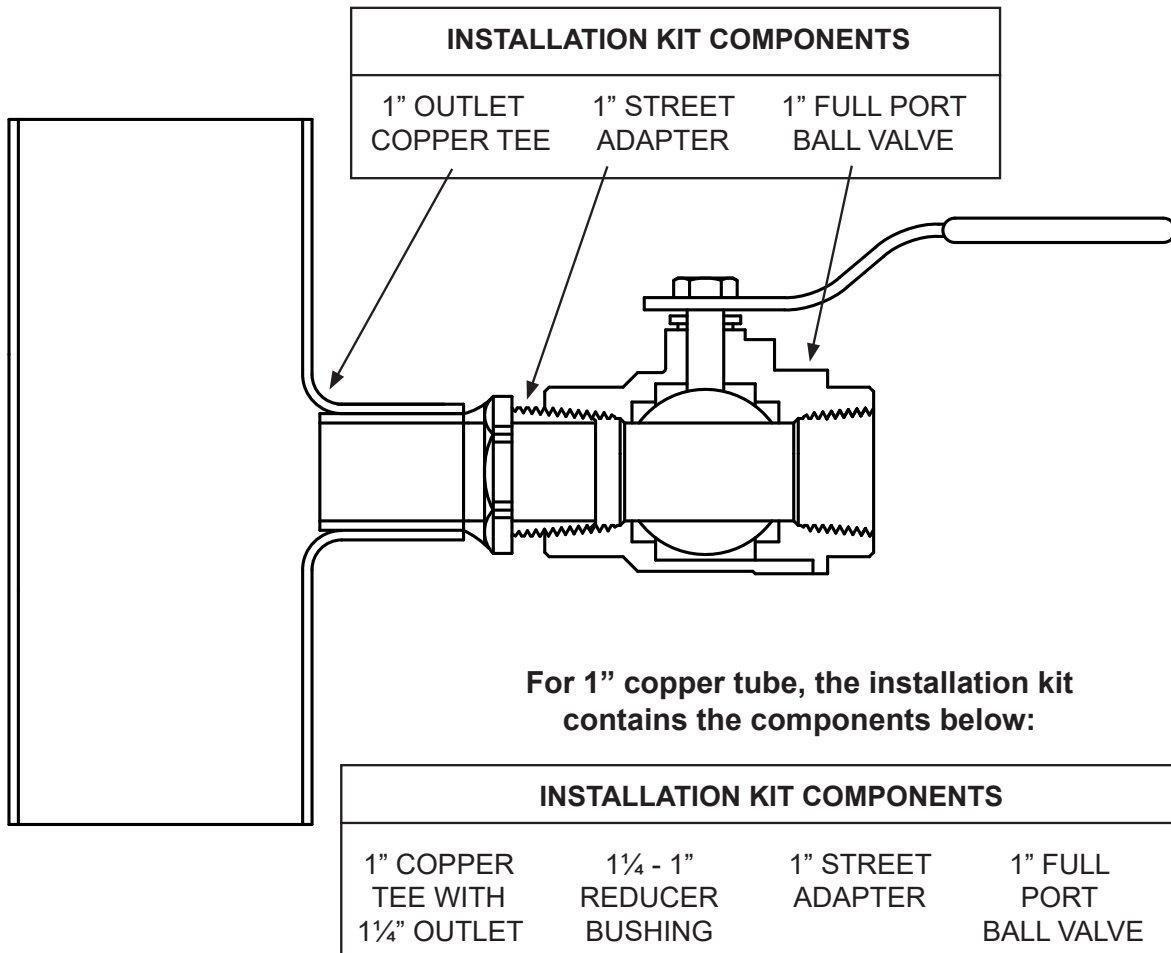

Installation Hardware Instructions
Hot Tap Installation Kit for Welded Steel Pipe
 For F-1000 Series & F-3500 Series Insertion Flow Meters

For Use With Kits: INSTL0002-FMH, INSTL02DW-FMH, INSTL0006-FMH, INSTL0031-FMH

This kit can be installed prior to filling the system, or into a section of pipe that is isolated from pressure and flow. Once installed, this kit allows for insertion and removal of the flow meter without a system shutdown.

Directions:

1. Identify an appropriate location for the flow meter.
2. Weld the branch outlet onto the pipe.
3. Install the close nipple and ball valve as shown below. Use a paste type thread sealant or use Teflon® tape. **DO NOT** use Teflon® tape for F-1100 & F-1200 Series.
4. Use a hot tap drilling machine with a 1" hole saw to drill the access hole.
5. Remove the drill; then flush all debris out of the valve.
6. Use the 1" reducer provided in this kit when installing the flow meter.

NOTE: Before installing the flow meter, read the entire installation manual.

IMPORTANT NOTE
 ONICON insertion flow meters are precision measuring devices that must be installed according to the instructions contained in this document in order to maintain their accuracy and reliability. Failure to follow these instructions will result in erratic operation and reduced accuracy.

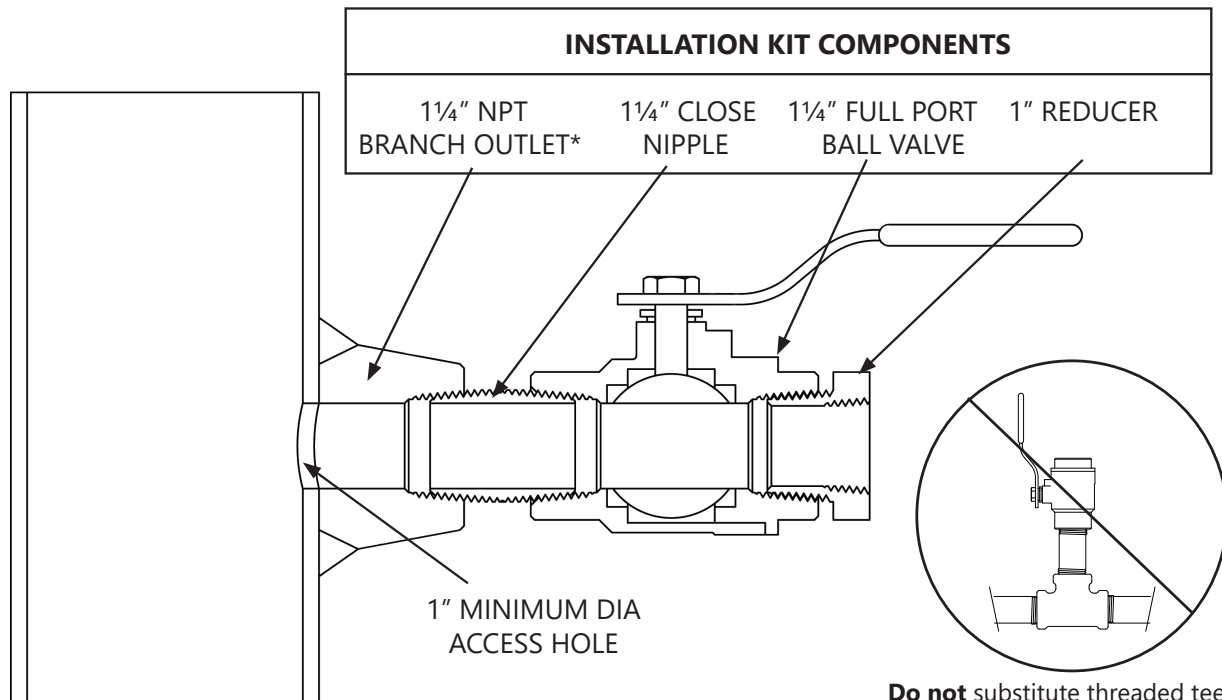

Do not substitute threaded tees for the welded branch outlet. Contact ONICON if you need installation hardware for threaded pipe.

* Customer supplied fusion outlet for HDPE/PPR pipes

Hot Tap Installation Kit for Applications Requiring Pipe Saddles

For F-1000 & F-3500 Series Insertion Flow Meters

For Use With Kits: INSTL019A-FMH, INSTL019B-FMH, INSTL0021-FMH, INSTL0022-FMH

This kit can be installed on a pressurized pipe. A hot tap drilling machine is used to create a one inch opening in the pipe wall. Once installed, this kit allows for insertion and removal of the flow meter without a system shutdown.

Directions:

1. Identify an appropriate location for the flow meter.
2. Clamp the saddle onto the pipe; refer to manufacturer's instructions.
3. Install the close nipple and ball valve as shown below. Use a paste type thread sealant or use Teflon® tape. DO NOT use Teflon® tape for F-1100 & F-1200 Series.
4. Use a hot tap drilling machine with a 1" hole saw to drill the access hole.
5. Remove the drill; then flush all debris out of the valve.
6. Use the 1" reducer provided in this kit when installing the flow meter.

NOTE: Before installing the flow meter, read the entire installation manual.

IMPORTANT NOTE
ONICON insertion flow meters are precision measuring devices that must be installed according to the instructions contained in this document in order to maintain their accuracy and reliability. Failure to follow these instructions will result in erratic operation and reduced accuracy.

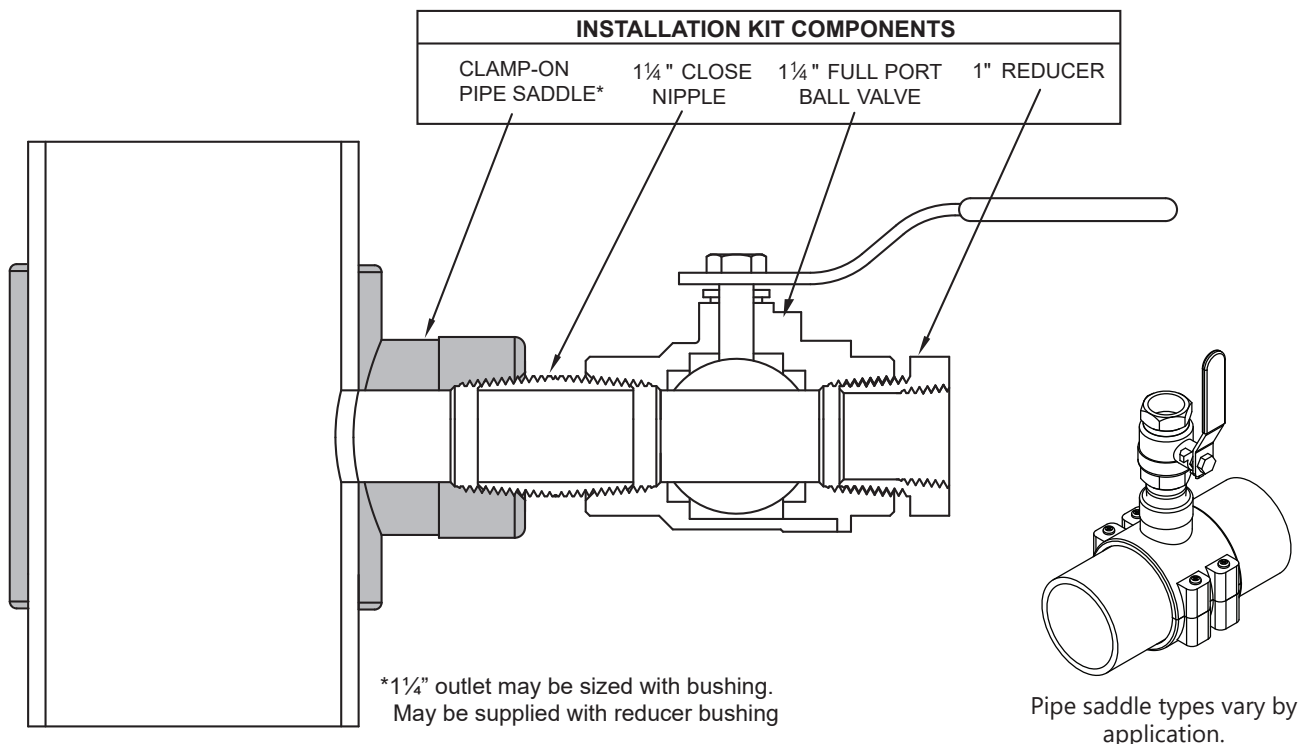

IMPORTANT NOTE
ONICON provides pipe saddles to facilitate the installation of our flow meters. These saddles are purchased from leading manufacturers who provide quality products. Separate installation instructions accompany the saddle. Please follow these instructions when installing the saddle. Pay particular attention to bolt torque specifications and temperature/pressure limits.

APPENDIX C

Turbine Assembly Detail Drawings

Turbine Assembly Details for All Models in F-1100 Series

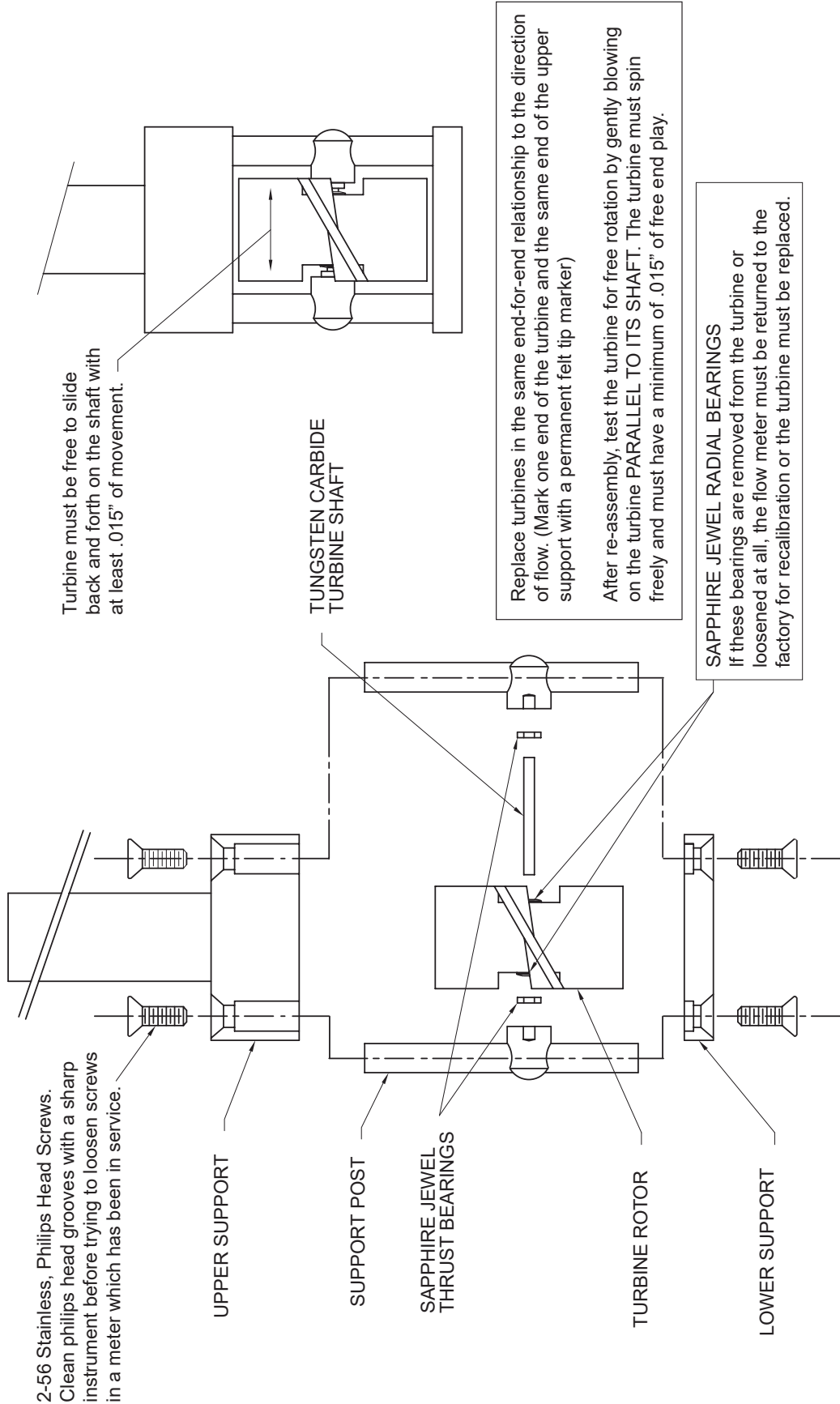

Turbine Assembly Details for All Models in F-1200 Series

