



# ONICON

Flow and Energy Measurement

## SYSTEM-1000 FLOW AND ENERGY MEASUREMENT SYSTEM

ONICON's System-1000 Flow and Energy Measurement System is the advanced multi-channel interface for accurately measuring and reporting thermal energy usage, flow, temperatures, efficiency, and other engineering parameters required by today's High Performance Buildings.



We believe in our products, so should you.

**1 YEAR NO FAULT WARRANTY**  
**3 YEAR MANUFACTURER WARRANTY**



Chiller 1		Cooling Tower	
Mode	Cooling	Mode	Cooling
Energy	384.4BTU/Hx1k	Energy	962.5BTU/Hx1k
En Tot	192.2BTUx1M	En Tot	391.1BTUx1M
Flow	64.0GPMx1	Flow	102.3GPMx1
Supply Temp	55.0F	Supply Temp	81.8F
Delta Temp	12.0F	Delta Temp	18.8F
Chiller 2		Boiler	
Mode	Cooling	Mode	Heating
Energy	385.6BTU/Hx1k	Energy	307.6BTU/Hx1k
En Tot	193.4BTUx1M	En Tot	72925.3BTUx1k
Flow	63.2GPMx1	Flow	32.7GPMx1
Supply Temp	55.1F	Supply Temp	120.9F
Delta Temp	12.2F	Delta Temp	18.8F
04/23/2025		13:52:07	

**SYSTEM-1000 Series**

Flow and Energy Measurement System

Engineered • Wet Calibrated • Factory Configured

## Measure with Confidence

No-Fault Warranty • On-Time Delivery • Customer Support

- Chilled Water • Heating Hot Water • Condenser Water •
- Domestic Hot Water • System Efficiency •

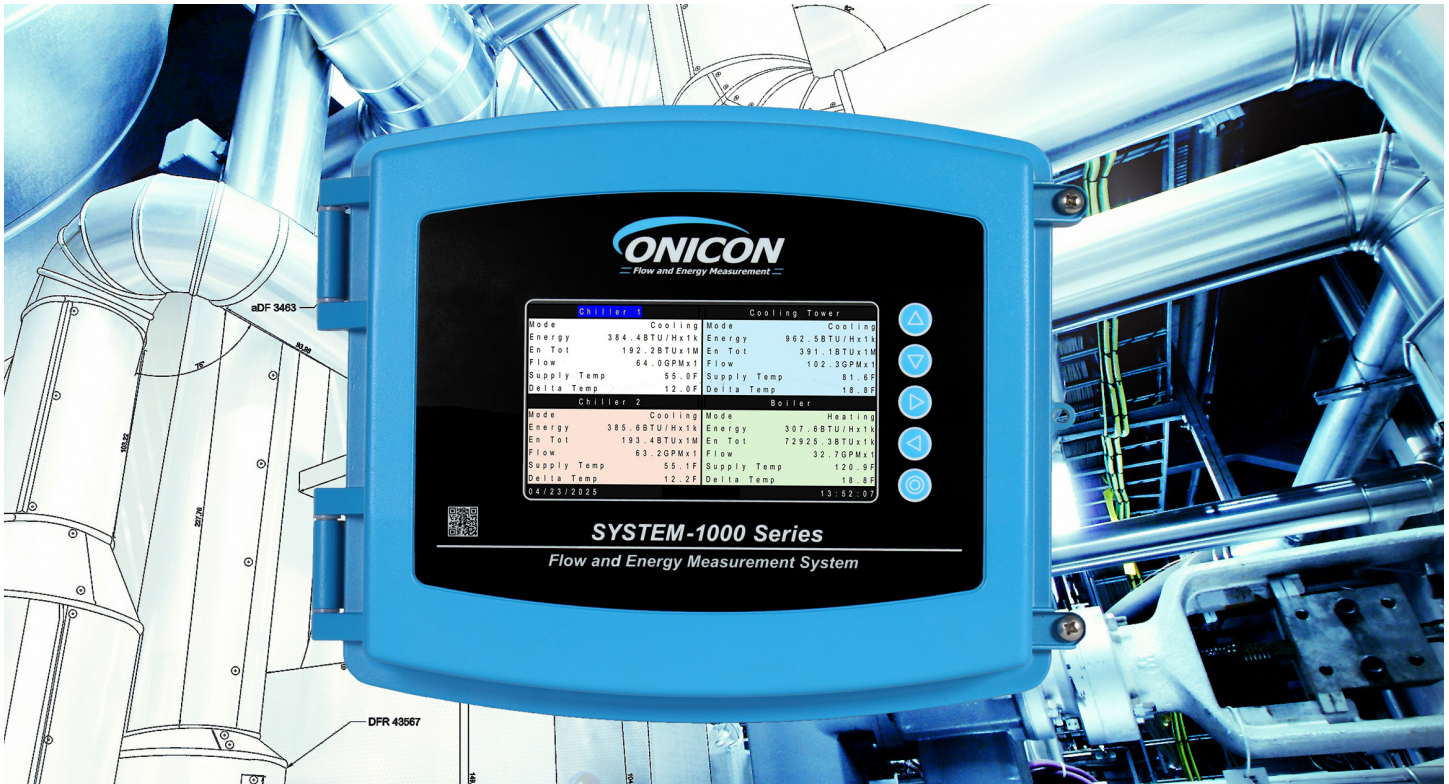

## DESCRIPTION

The System-1000 Flow and Energy Measurement System is a multi-channel BTU Meter that provides highly accurate thermal energy measurement in chilled water, heating hot water, condenser water, and domestic water systems on up to four independent channels. Energy measurement is based on signal inputs from matched precision temperature sensors and any of ONICON's inline, insertion, or clamp-on style flow meters.

The System-1000 can perform up to four thermal energy calculations simultaneously, and it allows for the addition or subtraction of two flow rates to solve challenging flow measurement locations.

The System-1000 utilizes calculated thermal energy data and uses electrical energy data via analog input to calculate the real-time coefficient of performance (COP) for a CHW system. Alternately, for HHW systems COP can be calculated against Steam or Gas flow inputs.

The flexible design provides energy, flow, temperature, and efficiency data on the local display via BACnet MS/TP or IP, OR Modbus RTU or TCP/IP, and via analog and pulse outputs. Auxiliary pulse and analog inputs are also available to allow other devices to provide rate and total data to the serial network.

## APPLICATIONS

The System-1000 is ideal to measure up to four applications simultaneously. Typical applications include a combination of chilled water, heating hot water, or condenser water systems for:

- Chilled water and heating hot water systems
- Total chiller performance and efficiency
- University campus monitoring
- Central plant monitoring
- Domestic water including recirculation lost
- Thermal/Ice storage systems
- Lake, solar, geothermal, ground sourcing energy monitoring
- Performance contracting energy monitoring
- Commercial office tenant billing
- Institutional energy cost allocation
- Glycol/Water or other mixtures loops

**FEATURES**

**Total System Integration** – The System-1000 works simultaneously with any of ONICON’s inline, insertion, or clamp-on style flow meters. This integration ensures the best metering technology can be chosen for all applications and its adaptable design brings all measurement devices to a single display. The System-1000 offers a complete integration for chilled or heating hot water loop flow rates and its make-up water lines, steam mass flow rate, and gas consumption; including other inputs for electric metering integration or DP signals.



**Multiple Flow Meter Options** - The System-1000 may be ordered with up to eight (8) flow meters. Four (4) reserved for energy calculation, (4) auxiliary inputs for electric, steam, gas, or water flow rates, and (4) auxiliary pulse inputs for totalization or alarm contact such as leak detectors. The System-1000 can also accept non-ONICON flow meters via 4-20mA signals or contact pulses.

**Multiple Temperature Sensor Options** - The System-1000 may be ordered with a pair of ONICON’s matched precision current based sensors or a pair of platinum RTDs. Each option offers exceptional accuracy and reliability. Four channel BTU operations requires 2 pairs of ONICON temperature sensors and 2 pairs of RTDs.

**Network Communication and Outputs** – The System-1000 is a central hub to connect multiple devices to the BMS/BAS through a single network connection. Now capable of connecting with BACnet MS/TP or IP, OR Modbus RTU or TCP/IP. The System-1000 is an excellent solution for bringing together multiple devices that lack network connectivity. Eight (8) analog outputs are provided for energy, flow, temperature, efficiency, and other options. Eight (8) pulse outputs are provided for totalization, alarm, and system status.

**Wall Space Reduction** – The multiple inputs of the System-1000 reduce the number of local displays needed in the room. The single point of use makes for an easily accessible view of all measurement parameters, and provides the user a live measurement value.

**Simple Installation and Commissioning** – Factory programmed and ready to use upon delivery. All process data and programming functions are accessible via front panel display and keypad. Advanced diagnostics are available to confirm wiring connection and accurate system performance. All mechanical installation hardware, color coded interconnecting cabling, and installation instructions are provided to ensure error-free installation.

**Non-Ideal Installation Solutions** – The System-1000 provides a solution for limited straight run installations by utilizing addition or subtraction of meters that can be placed in longer pipe runs. This addition function utilizes multiple sub-meter inputs to generate a total flow through tees or headers. Alternately, the subtraction function can be used to identify what each piece of equipment supplies to a header or, determining the true energy required for a domestic hot water usage by excluding the recirculation losses.

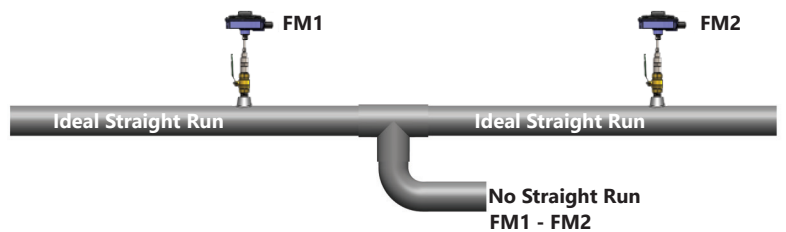
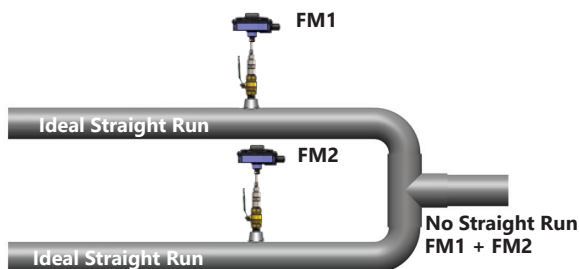

**SPECIFICATIONS\***

<b>SYSTEM-1000 TRANSMITTER</b>			
PERFORMANCE	CALCULATOR ACCURACY	Computing nonlinearity within $\pm 0.05\%$	
	TEMPERATURE ACCURACY / AVAILABLE OPTIONS	Precision solid state current based sensors. Signal (mA) is unaffected by wire length. Overall differential temperature measurement uncertainty of $\pm 0.15^\circ\text{F}$ over the application range. Liquid temperature range: $32^\circ\text{F}$ to $200^\circ\text{F}$	
		1000 $\Omega$ platinum RTDs calibrated to a differential measurement uncertainty of $\pm 0.18^\circ\text{F}$ over the stated range	
FLOW RATE	See accuracy statement provided with the flow meter (ordered separately)		
MECHANICAL	DIMENSIONS	13.96" W x 12" H x 6.04" D	
MATERIALS	ENCLOSURE	ADC12 Die Cast Aluminum	
ENVIRONMENTAL	OPERATING TEMPERATURE RANGE	$-13^\circ\text{F}$ to $140^\circ\text{F}$	
	ENCLOSURE RATING	NEMA 13	
POWER SUPPLY REQUIREMENTS	24 VAC/DC	22 - 28 V DC/AC, 50/60Hz, 100VA	
	120-240 VAC	99 - 126 VAC or 196 - 253 VAC, 50/60Hz, 200VA	
I/O SIGNALS	ONE CHANNEL CONFIGURATION	Frequency Inputs	Two (2) Active Frequency Inputs
		Analog Inputs	Two (2) Active Analog Inputs
		Digital Inputs	Two (2) Open Collector / Isolated Dry Contact for totalization or alarm
		Temperature Sensor Inputs	Two (2) Passive Analog Inputs or Two (2) 1000 $\Omega$ RTD Inputs
		Analog Outputs	Four (4) Active Analog Outputs
		Digital Outputs	Four (4) Isolated Dry Contact Inputs for Totalization or Alarm
	TWO AND FOUR CHANNEL CONFIGURATION	Frequency Inputs	Four (4) Active Frequency Inputs
		Analog Inputs	Four (4) Active Analog Inputs
		Digital Inputs	Four (4) Open Collector / Isolated Dry Contact for totalization or alarm
		Temperture Sensor Inputs	Four (4) Passive Analog Inputs or (4) 1000 $\Omega$ RTD Inputs
		Analog Outputs	Eight (8) Active Analog Outputs
		Digital Outputs	Eight (8) Isolated Dry Contact Inputs for Totalization or Alarm
NETWORK CONNECTIONS	Isolated RS485 serial interface or IP ethernet port connection		
COMMUNICATION PROTOCOLS	BACnet MS/TP, BACnet UDP/IP, MODBUS RTU, MODBUS TCP/IP		

\* SPECIFICATIONS subject to change without notice.

**SPECIFICATIONS CONTINUED\***

<b>SYSTEM-1000 TRANSMITTER (CONTINUED)</b>			
NETWORK CONFIGURATION & ADDRESSING	BACnet MS/TP	BAUD RATES	9600, 19200, 38400, 57600, or 76800 (Default: 38400)
		DEVICE ADDRESS RANGE	1 – 127 (Default: 017)
		DEVICE INSTANCE RANGE	1 – 4,194,302 (Default: 57017)
		Max Master	1-127
	BACnet/IP	IPV4 Address	Programable (Default: 192.168.1.24)
		Instance Number	1 – 4,194,302 (Default:57017)
		Subnet Mask	Programmable (Default:255.255.255.0)
		Gateway Address	Programmable
		UDP port:	Programmable (Default:47808)
		DHCP	Available
	MODBUS RTU	Address Range	1 - 247 (Default: 017)
		Baud Rate	9600, 19200, 38400, 57600, or 76800 (Default: 19200)
		Data Format	8 Bit (Stop Bits: 1)
		Parity	Even, Odd, None (Default: Even)
		Byte Order	ABCD
	MODBUS TCP/IP	IPV4 Address	Programmable (Default: 192.168.1.24)
		Subnet Mask	Programmable (Default: 255.255.255.0)
		Gateway Address	Programmable
		Port	Programmable (Default: 502)
DHCP		Available	
APPROVALS	FCC	Part 15, Subpart B	
	UL	UL 61010	
	CE		

\* SPECIFICATIONS subject to change without notice.

**DIMENSIONS**

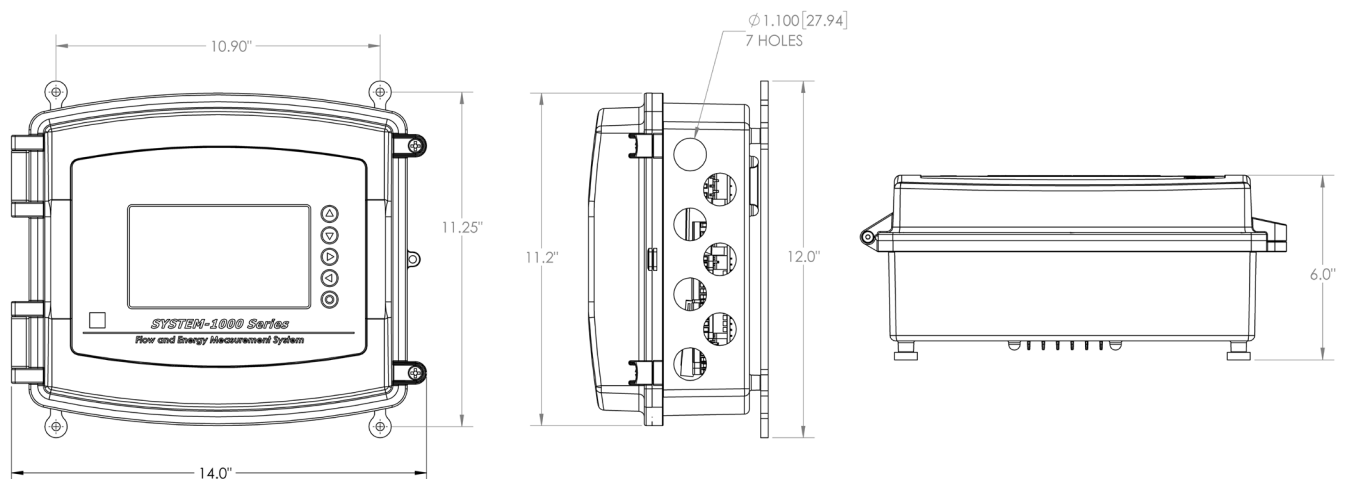

**TYPICAL INSTALLATION**

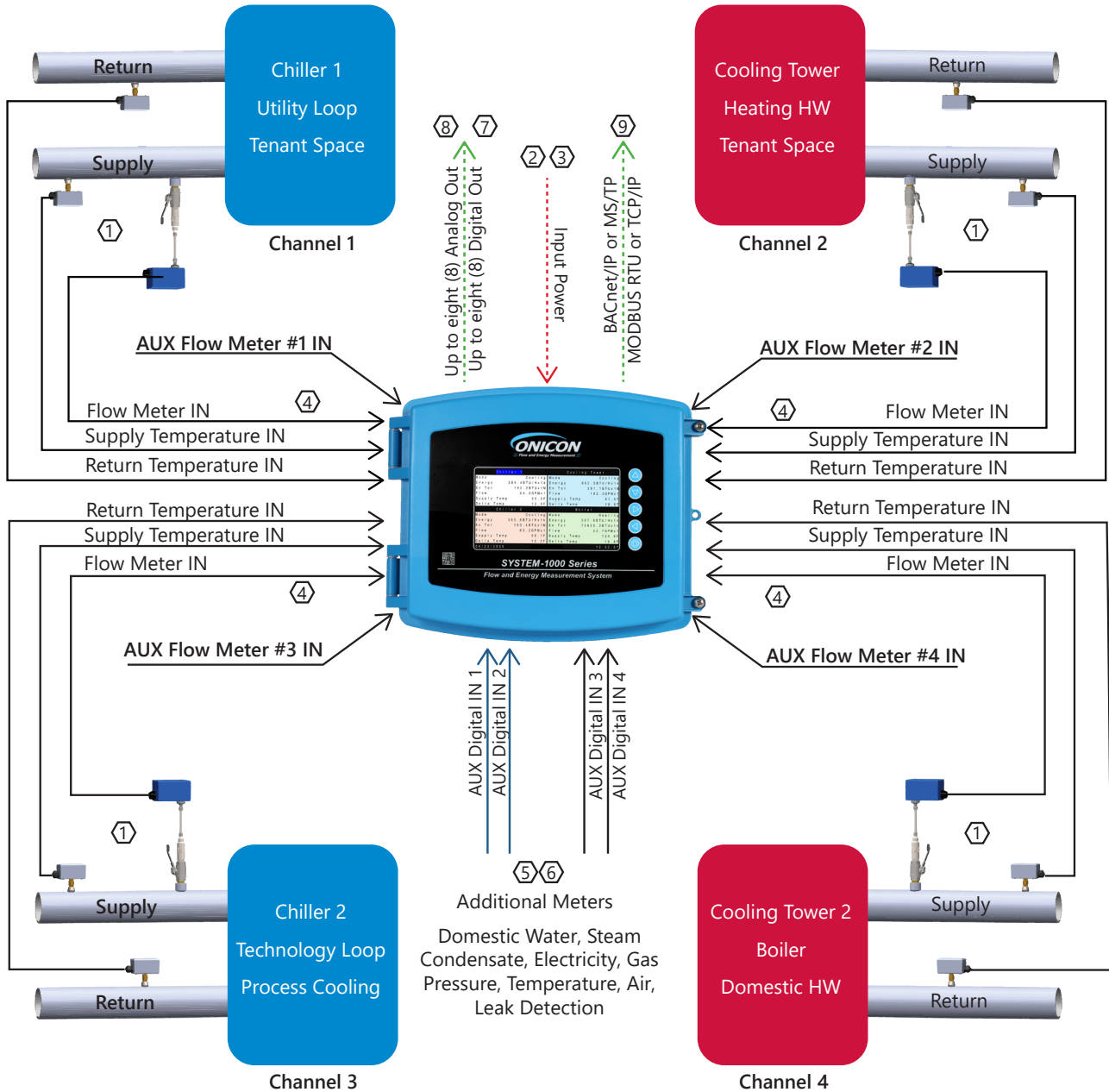

1. ONICON Flow Meters and Temperature Sensors are provided separately
2. Provide a Power supply 24VAC/DC, 100VA Class II or 120/230 VAC 50/60 Hz, 200VA
3. Provide sufficient power supply when the combined current of all devices connected to the SYS-1000 exceeds 1 Amp
4. Flow Meter and Temperature sensors used for thermal energy calculations
5. Auxiliary Digital Inputs are available for close contact alarm signals and totalization
6. Auxiliary Digital Inputs designed for Dry or Wet Contact and Open Collectors
7. Digital Outputs are available for Energy Totals, Flow Totals, Operating Modes, and Alarms
8. Analog outputs are available for Energy Rate, Flow Rate, Supply Temp, Return Temp, Efficiency, and Aux Inputs
9. BACnet® IP or MS/TP OR MODBUS RTU or TCP/IP

**DESIGNED FOR NETWORKING**

The System-1000 provides the user with a single point of communication to all the devices connected to it. It has BACnet MS/TP or BACnet UDP/IP. Interval data for energy and volume are provided along with operating status and diagnostic data.

System-1000 alarms can be configured to the upper and lower limits of specific BACnet objects and provide custom alarm states at the meter display. The new BACnet stack includes:

- **Stack Modularity:** Traditional polling methods of data acquisition are supported and Change-of-Value (COV) notifications report changes to the network on an interrupt basis (without polling)
- **Intrinsic Reporting:** Provides detailed control for customers to specify when notifications should occur, and additional metrics that can be used for quick diagnosis
- **Foreign Server Registration:** Allows a unit to be remotely routed to another BACnet network over IP, relieving the need for the customer to install multiple BACnet clients or routers
- **Advanced Network Diagnostics:** Network time synchronization for troubleshooting and isolating meters from other facility issues. Network-accessible event logs provide a record of changes and power events for further aid in troubleshooting

The following information and more are available over the network:

BACnet Data	
Data	Available Data Object
Energy	Instantaneous Rate / total / Y-T-D Total/ Prev. Yr. Total/ User Resettable Totals
Volume	Instantaneous Rate / total / Y-T-D Total/ Prev. Yr. Total/ User Resettable Totals
Temperature	Supply Temp/ Return Temp/ Delta Temp
Status	Operating Status / Mode Status (heating/ Cooling) / Alarms (On/Off)
Efficiency (COP)	Instantaneous Rate

**METER ORDERING INFORMATION**  
**Meter Model Number Coding = SYS-1X00-ABC**

**X = System Configuration**  
 1 = Single Channel System  
 2 = Dual Channel System  
 4 = Four Channel System

**A = Electronics Enclosure**  
 1 = NEMA 13 enclosure with LCD display

**B = Input Power**  
 1 = 24 VAC/DC, 100 VA  
 2 = 120 / 230 VAC, 200 VA

**C = Network Communications**  
 0 = No communications  
 1 = RS-485 & IP Communications. BACnet, MODBUS

