

Standard Thermowell Hardware Installation Instructions For System-10 BTU Meters



IMPORTANT NOTE

ONICON BTU Meters are precision measuring devices that must be installed according to the instructions contained in this document in order to maintain their accuracy and reliability.

The thermowells provided in this kit are supplied for use with a specific pipe diameter and with the thermowell length matched to the temperature sensor length. Matching the thermowell to the pipe diameter ensures that the thermowell will be fully immersed in the flow stream. Matching the sensor length to the thermowell ensures that the temperature sensor will contact the bottom of the well and provide an accurate, responsive temperature measurement.

This kit must be installed prior to filling the system, or into pipe sections which are isolated from pressure and flow. Once installed, this kit allows for the insertion and removal of temperature sensors without a system shutdown.

Directions:

1. Confirm that the kit provided matches the installation location, pipe diameter and pipe material. Contact ONICON if there is any discrepancy.
2. Identify an appropriate location for each thermowell based on the information presented on page 2 of this document.
3. Follow the detailed instructions appropriate for each pipe material. This information is presented on the following pages.

NOTE: Read the entire Btu meter manual before installing the temperature sensors.

Thermowell Site Selection General Guidelines

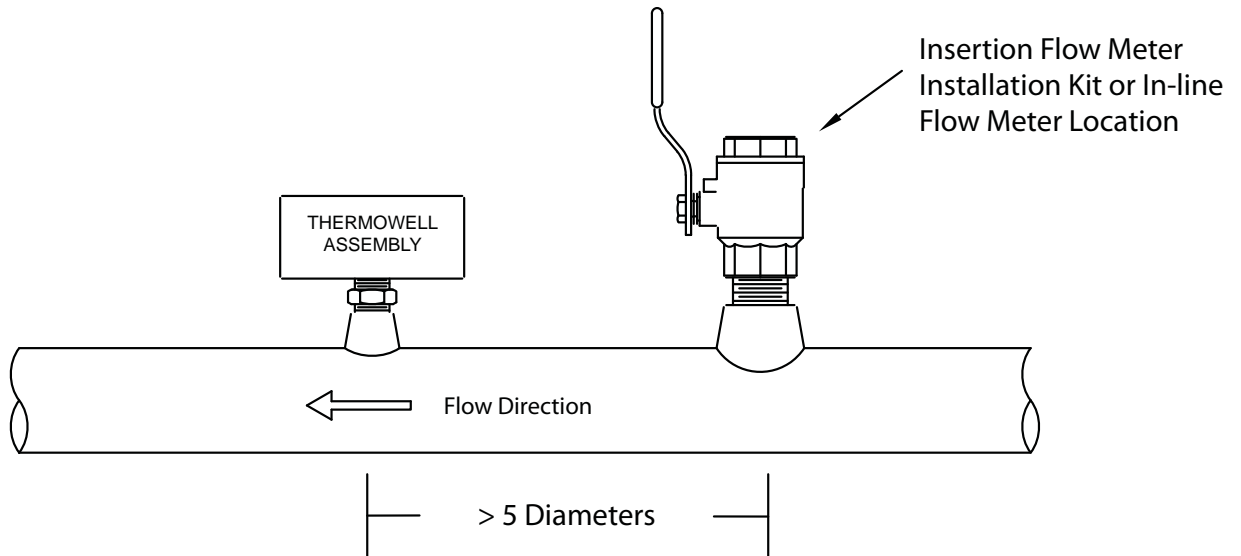

One sensor will be located in the same pipe with the flow meter. This sensor must be located at least 12" or 5 pipe diameters, whichever is greater, downstream from the flow meter.

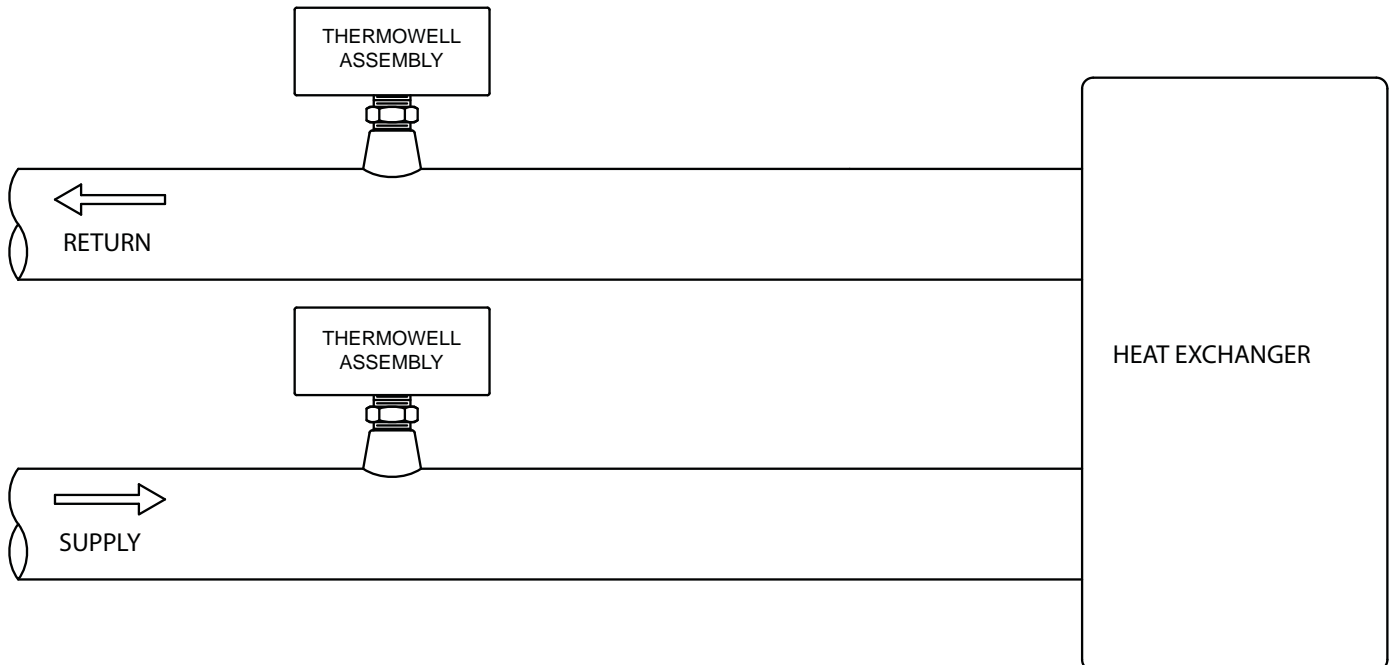

The supply and return sensors should be located in the piping system such that they only measure the temperature of the liquid flowing immediately in to and out of the section of the piping system where the energy measurement is made.

Installation Detail for Common Pipe Materials



Copper Tee

ONICON furnished
Junction Box

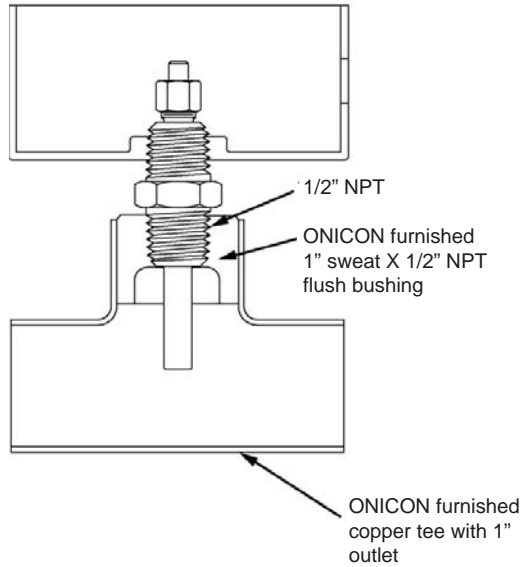

Threaded Tee

ONICON furnished
Junction Box

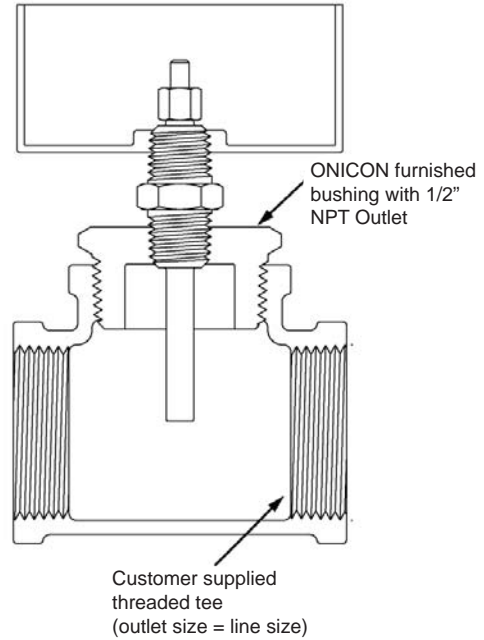

Welded Pipe

ONICON furnished
Junction Box

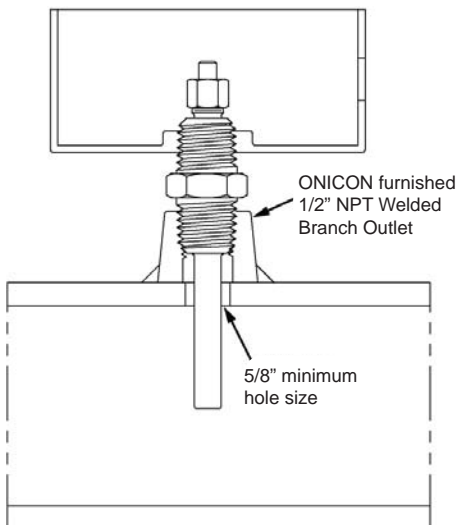

PVC Tee

ONICON furnished
Junction Box

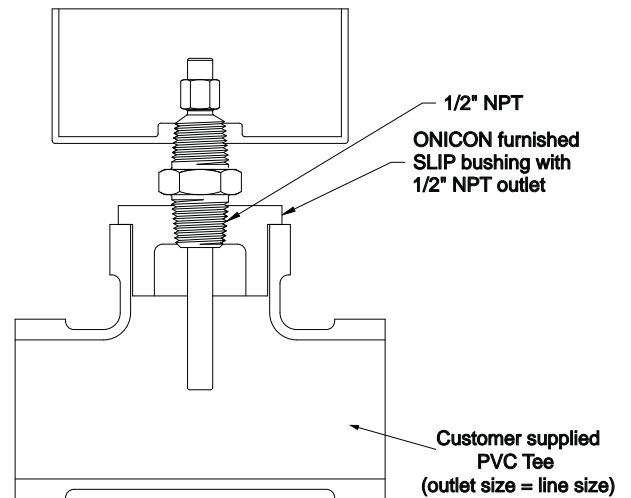

CAUTION

The use of multiple reducer bushings to size the opening for the thermowell will reduce the insertion depth of the thermowell and may lead to temperature sensor measurement errors.



1500 North Belcher Road, Clearwater, FL 33765 • Tel (727) 447-6140 • Fax (727) 442-5699
www.onicon.com • customerservice@onicon.com