

SERIES D-1400



PORTABLE DISPLAY MODULE



Model D-1402 Shown

The D-1400 series of Portable Display Modules are battery powered, hand held units which can be taken into the field wherever flow measurements are needed. An internal battery powers both the liquid crystal display and an ONICON single or dual turbine flow meter. The display module and flow meter together make up a complete metering system which can be used to accurately determine the flow rate in full pipes and open flow channels. Hot tap valve assemblies enable one of these portable systems to measure flow rates in multiple locations.

Operation of the display module is simple. The D-1401, used with a single turbine flow meter, indicates turbine frequency in hertz. The D-1402, used with a dual turbine flow meter, displays the frequency of the upper turbine, lower turbine, or the average of the two. A conversion chart allows the user to convert frequency to volumetric flow rate (GPM) in any pipe size.

SERIES D-1400

MECHANICAL

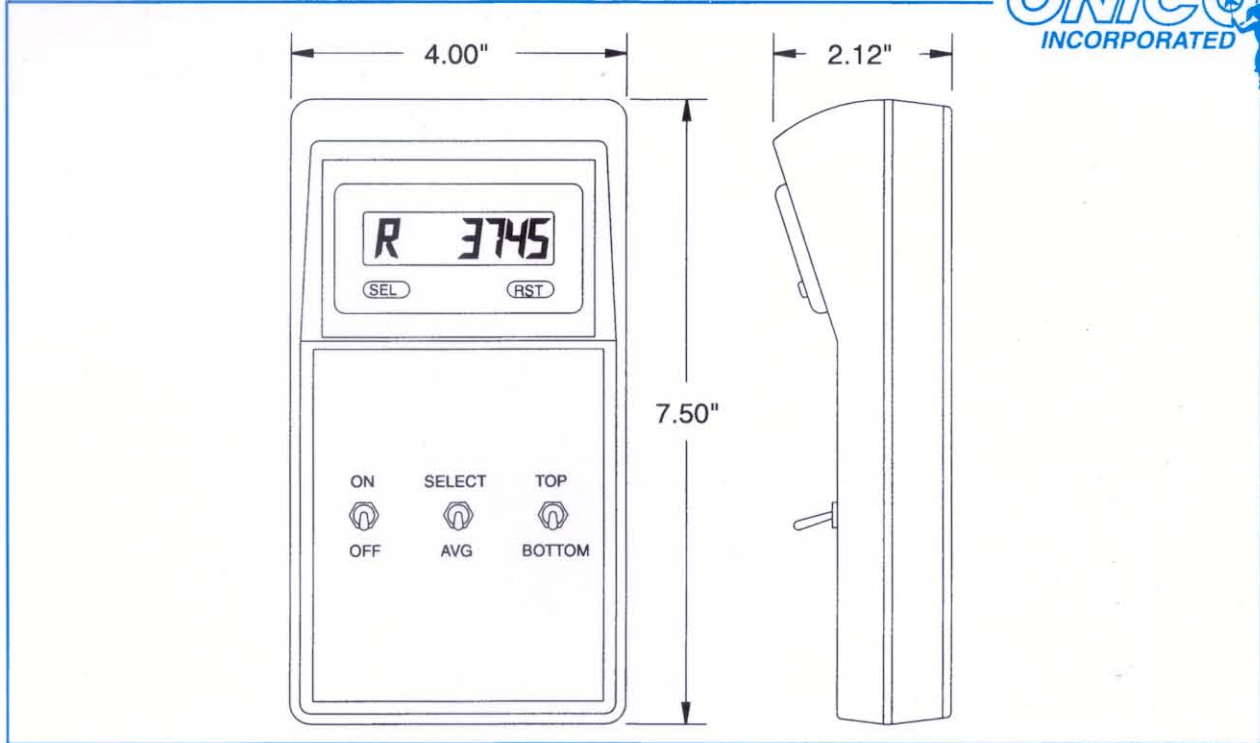

Model D-1402 Shown

NOTE:

The flow meters which are supplied with the D-1400 series hand held displays have interface circuitry which allows battery operation. Standard Onicon flow meters are not compatible with the D-1400 series display units.

Notes:

SPECIFICATIONS

MECHANICAL:

Heavy duty plastic enclosure with sliding door for battery

WIRING:

Prewired inline cable connector for flow meter connection

ENVIRONMENTAL TEMPERATURE RANGE:

32-130 Deg F

POWER SUPPLY:

9 V battery (NEDA Type 1604) in rear compartment powers the flow meter and LCD display

RATE INDICATOR (standard):

Type: Six digit LCD with 0.46" numerals

Calibration: Set at factory to read turbine frequency in hertz. A conversion chart allows the user to convert frequency to volumetric flow rate (GPM) in any pipe size.

Factory will set to read GPM or any other units for particular pipe size if requested.

Field programming possible

Memory: Nonvolatile E²PROM memory retains all programming parameters and count value in the event of power interruption.