

Installation Hardware Instructions

Standard Installation Kit For Copper Tube

(Complies with NSF61)



For F-3500 Series Insertion Electromagnetic Flow Meters

For Use With Kits: INSTL84 & INSTL85

This kit must be installed prior to filling the system, or into a section of pipe that is isolated from pressure and flow. Once installed, this kit allows for insertion and removal of the flow meter without a system shutdown.

Directions:

1. Identify an appropriate location for the flow meter (see pages 2-3).
2. Solder or braze the copper tee and adapter provided.
3. Install the ball valve as shown below. Use a paste type thread sealant and/or Teflon® tape.
4. Flush and fill the system prior to installing the meter.

NOTE: Before installing the flow meter, read the entire installation manual.

Important Note
ONICON insertion flow meters are precision measuring devices that must be installed according to the instructions contained in this document in order to maintain their accuracy and reliability. Failure to follow these instructions will result in erratic operation and reduced accuracy.

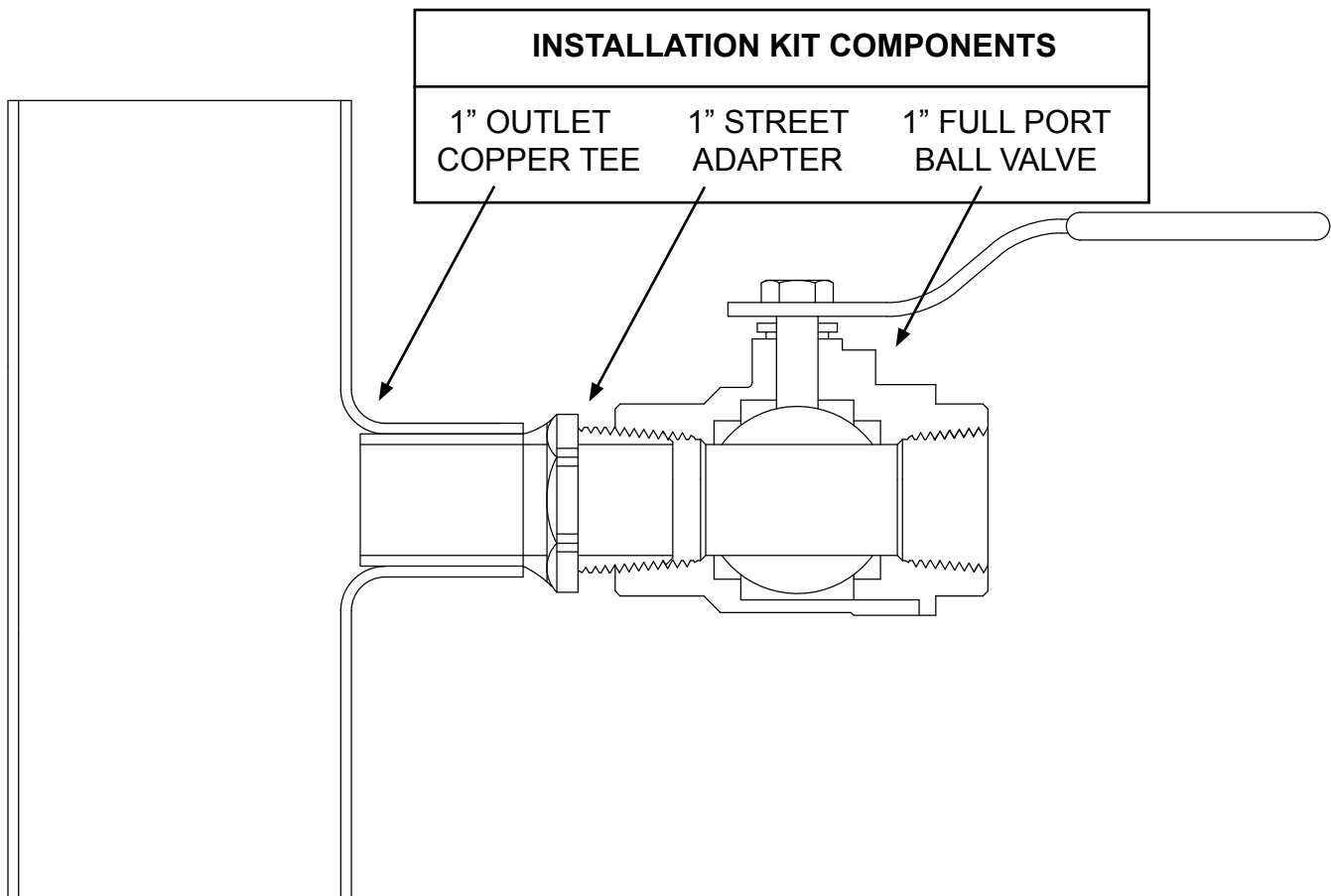

FLOW METER SITE SELECTION GENERAL GUIDELINES

- For 3" and larger diameter pipes
- Install in vertical or horizontal pipe
- For horizontal pipe position meter anywhere in upper 240°

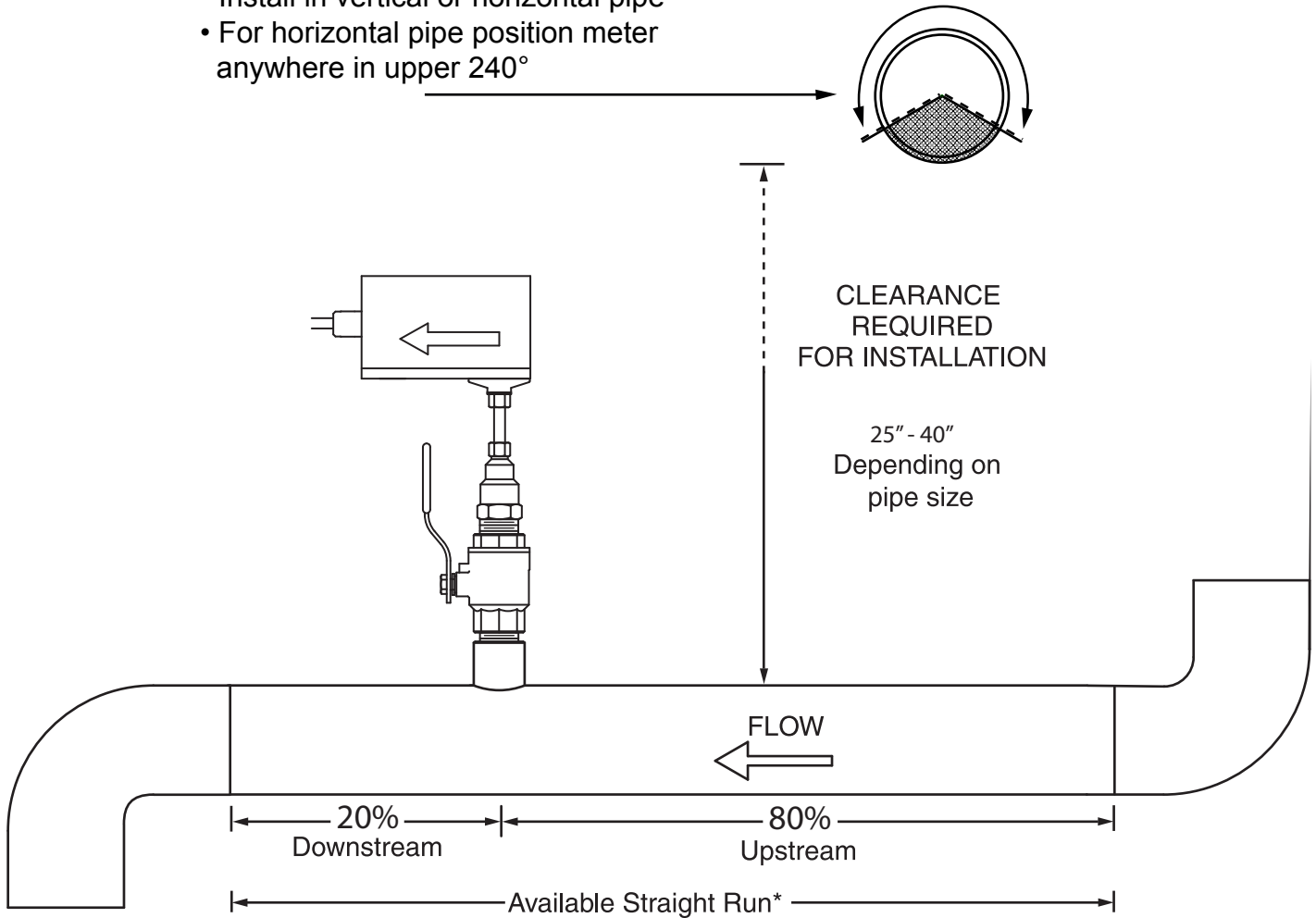

*See following pages for model specific straight run requirements.

EVALUATING UPSTREAM PIPING CONDITIONS

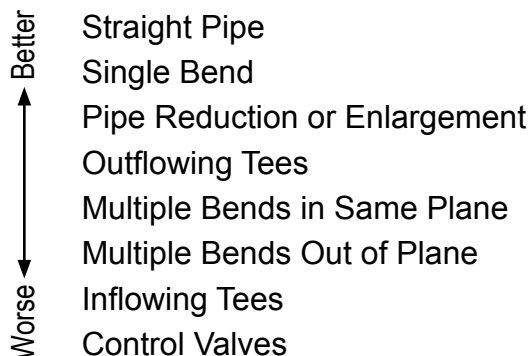

How to determine the available straight pipe diameters:

For each application, locate the longest straight, unobstructed section of pipe (no bends, tees, valves, other insertion probes, size transitions). The longest straight pipe run in inches divided by nominal pipe size in inches equals "diameters of straight pipe." For closed loop applications, consider both the supply and return lines as possible locations.

STRAIGHT RUN REQUIREMENTS FOR INSERTION ELECTROMAGNETIC FLOW METERS

GENERAL PRACTICES:

1. For best results, install the flow meter in a straight run of pipe, free of bends, tees, valves, transitions and obstructions.
2. Straight run requirements vary based on the nature of the upstream obstruction. See the table below for guidelines in determining upstream straight run requirements based on the nature of the obstruction.
3. If there is insufficient straight run, allow 80% of the run upstream and 20% of the run downstream. If the total length of straight run is less than 70% of the recommended distance, performance may seriously degrade, and consideration should be given to changing to the series F-3000 In-line Electromagnetic flow meter.

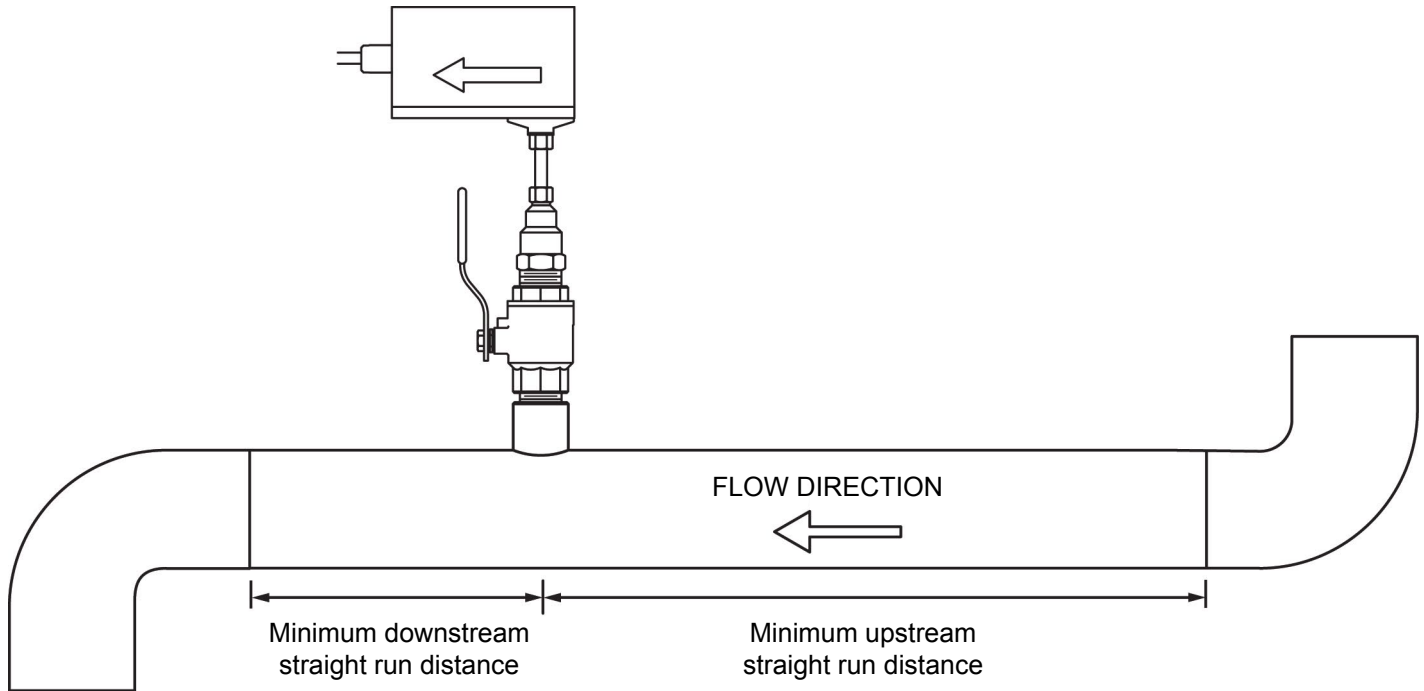

Upstream obstruction	Straight run required upstream of meter location	Straight run required downstream of meter location
Single bend preceded by ≥ 9 diameters of straight pipe	10 Diameters	5 Diameters
Pipe size reduction / expansion in straight pipe run	10 Diameters	5 Diameters
Single bend preceded by ≤ 9 diameters of straight pipe	15 Diameters	5 Diameters
Outflowing tee / Pump outflow	20 Diameters	5 Diameters
Multiple bends out of plane	30 Diameters	5 Diameters
Modulating valve	30 Diameters	5 Diameters

IMPORTANT NOTE

Always use the maximum available straight run. When more than the minimum required straight run is available place the meter such that the excess straight run is upstream of the meter location.



1500 North Belcher Road, Clearwater, Florida 33765 • Tel (727) 447-6140 • Fax (727) 442-5699