

**F-5100 Inline  
Thermal Mass Flow Meter  
Installation and Operation Guide**



## SAFETY INFORMATION

This meter was calibrated at the factory before shipment. To ensure correct use of the meter, please read this manual thoroughly.

Regarding This Manual:

- This manual should be passed on to the end user.
- Before use, read this manual thoroughly to comprehend its contents.
- The contents of this manual may be changed without prior notice.
- All rights reserved. No part of this manual may be reproduced in any form without ONICON's written permission.
- ONICON makes no warranty of any kind with regard to this material, including, but not limited to, implied warranties of merchantability and suitability for a particular purpose.
- All reasonable efforts have been made to ensure the accuracy of the contents of this manual. However, if any errors are found, please inform ONICON.
- ONICON assumes no responsibilities for this product except as stated in the warranty.
- If the customer or any third party is harmed by the use of this product, ONICON assumes no responsibility for any such harm owing to any defects in the product which were not predictable, or for any indirect damages.

Safety Precautions:

The following general safety precautions must be observed during all phases of installation, operation, service, and repair of this product. Failure to comply with these precautions or with specific WARNINGS given elsewhere in this manual violates safety standards of design, manufacture, and intended use of the product. ONICON Incorporated assumes no liability for the customer's failure to comply with these requirements. If this product is used in a manner not specified in this manual, the protection provided by this product may be impaired.

The following symbols are used in this manual:



### WARNING

Messages identified as WARNING contain information regarding the personal safety of individuals involved in the installation, operation or service of this product.



### CAUTION

Messages identified as CAUTION contain information regarding the potential damage to the product or other ancillary products.



### IMPORTANT NOTICE

Messages identified as IMPORTANT NOTICE contain information critical to the proper operation of the product.

## TABLE OF CONTENTS

1.0	INTRODUCTION .....	5
1.1	PURPOSE OF THIS GUIDE .....	5
1.2	TYPICAL INLINE THERMAL MASS FLOW METER.....	5
1.3	STANDARD FEATURES AND SPECIFICATIONS.....	6
1.4	ADDITIONAL HARDWARE THAT MAY BE REQUIRED.....	7
1.4.1	Additional Remote Mount Cable .....	7
1.4.2	Gaskets for Flanged Meters .....	7
1.5	WORKING ENVIRONMENT .....	7
1.6	WARRANTY & SERIAL NUMBER.....	7
2.0	UNPACKING .....	8
2.1	CHECKING TO SEE THAT YOU RECEIVED EVERYTHING.....	8
3.0	INSTALLATION.....	9
3.1	INSTALLATION SITE SELECTION .....	9
3.2	MECHANICAL INSTALLATION.....	12
3.2.1	Threaded Meter.....	12
3.2.2	Flanged Meter .....	13
3.3	ELECTRICAL INSTALLATION .....	15
3.3.1	Analog Output .....	15
3.3.2	Pulse Output .....	15
3.3.3	Integral Mount Wiring .....	16
3.3.4	Remote Mount Wiring .....	17
4.0	START-UP & COMMISSIONING FOR ONICON INSERTION THERMAL MASS FLOW METERS.....	18
4.1	DISPLAY .....	18
4.2	POWERING THE METER .....	18
4.3	HELPFUL HINTS FOR START-UP & COMMISSIONING .....	18
4.4	START-UP & COMMISSIONING.....	19
4.5	START-UP & COMMISSIONING WORKSHEET.....	20
5.0	TROUBLESHOOTING GUIDE.....	21
APPENDIX		
A-1	REMOTE MOUNT MECHANICAL HARDWARE.....	23
A-2	CONDITIONS OF SALE .....	24
A-3	USE OF THE INSERTION DEPTH GAGE	



## SECTION 1.0: INTRODUCTION

We, at ONICON Incorporated, would like to thank you for purchasing our quality American made F-5100 Series Thermal Mass Flow Meter. As our valued customer, our commitment to you is to provide fast reliable service, while continuing to offer you quality products to meet your growing flow measurement needs.

### 1.1 PURPOSE OF THIS GUIDE

We have written this guide to provide the persons responsible for the installation, operation and maintenance of your flow meter with the product specific information they will need. This is NOT an electrical or plumbing trade manual.



#### WARNING

Please do not permit persons to install, operate or maintain this equipment unless they have a complete knowledge of their trade skills and are competent to work on combustible gas and/or high pressure compressed air systems, according to their individual trades. Death or permanent injury may result from accidents with these systems.

This guide is the basic reference tool for all ONICON F-5100 Inline Thermal Mass Flow Meters. If you have not purchased all of the options, there will be references in this manual which are not applicable to your meter(s).

### 1.2 TYPICAL INLINE THERMAL MASS FLOW METER

Each ONICON thermal mass meter has a single pair of encapsulated platinum sensors that are in direct contact with the gas. The sensors consist of highly stable reference-grade platinum windings. One sensor is self-heated and serves as the flow sensor. The other acts as a reference sensor, and measures the gas temperature. Our proprietary sensor circuitry maintains a constant temperature differential between the flow sensor and the reference sensor.

As gas flows by the heated sensor (flow sensor), the molecules of flowing gas carry heat away and the sensor cools. The sensor circuitry continuously compensates for this cooling effect and maintains a constant temperature differential between the two sensors. The energy required to maintain this temperature differential is directly proportional to the mass flow. There is no need for additional temperature or pressure compensation.

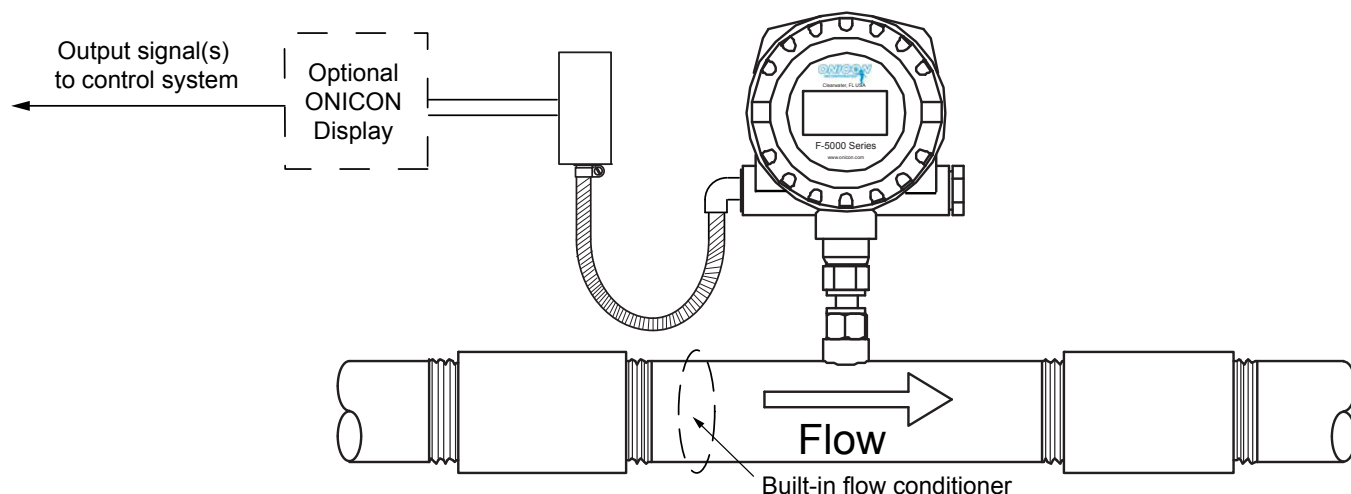

## 1.3 STANDARD FEATURES AND SPECIFICATIONS

### CALIBRATION

Every ONICON thermal mass flow meter is wet calibrated in a flow laboratory against standards that are directly traceable to N.I.S.T. A certificate of calibration accompanies every meter.

Standard Reference Conditions for Natural Gas:

Fluid: Methane

Fluid Temperature: 60°F

Fluid Pressure: 29.92" Hg (14.70 PSIA)

Standard Reference Conditions for Air:

Fluid: Air

Fluid Temperature: 70° F

Fluid Pressure: 29.92" Hg (14.70 PSIA)

Contact ONICON for reference conditions for other fluid types.

### ACCURACY

Natural Gas

± 1.0% of reading from 500 – 7000 SFPM

± 2.0 % of reading from 100 – 500 SFPM

Compressed Air

± 1.0 % of reading + 0.5% of scale over a

100:1 turndown

### OVERALL FLOW RANGE

5 to 35,000 SFPM

### SENSING METHOD

Thermal mass flow utilizing hybrid analog/digital sensing circuitry, no moving parts

### INPUT POWER

Standard: 24 VDC ±10%, 100 mA maximum current

Optional: 90-265 VAC, 50/60 Hz

Optional: 12 VDC ±10%, 200 mA maximum current

### FLUID TEMPERATURE RANGE

Standard: -40° to 200° F

Optional: 200° to 300° F

Optional: 300° to 450° F

Optional: 450° to 700° F

### AMBIENT TEMPERATURE RANGE

-5° to 150° F

### MAXIMUM OPERATING PRESSURE

Standard: 500 PSI

Optional: 1,000 PSI

### MATERIALS OF CONSTRUCTION

Wetted metal components - 316L stainless steel

Sensor head - Platinum windings encapsulated in 316L stainless steel

Electronics enclosure - Powder coat painted cast aluminum

Remote mount enclosure - Cast aluminum

### ENCLOSURE RATING

Weather-tight, NEMA 4 (All versions)

### APPROVALS

Integral and remote mount (24 VDC only) Class 1, Division 2, Groups B, C, & D,  
(ATEX: Ex nA IIC T4X)

### ELECTRICAL CONNECTIONS

Enclosed terminal blocks, cable access through two ½" NPT conduit fittings

### OUTPUT SIGNAL(S)

Analog output: 4-20 mA

Scalable pulse output: Active 24 VDC pulse, 500ms duration

### DISPLAY

Graphic OLED display indicates:

Bar graph indicating percentage of full scale flow

Flow rate: 7 digits

Flow total: 9 digits (Total rolls over to zero when maximum count is exceeded)

Fluid temperature: 3 digits

mWatts of energy used to heat flow sensor: 4 digits

Engineering units for rate and total

## 1.4 ADDITIONAL HARDWARE THAT MAY BE REQUIRED

### 1.4.1 Additional Remote Mount Cable

ONICON remote mount meters are provided with 25ft of cable. Additional cable lengths of up to 1000ft may be added without affecting the calibration of the meter.

Part #	Description
17350	25 ft of additional mount remote cable
17351	50 ft of additional remote mount cable
17352	100 ft of additional remote mount cable

### 1.4.2 Gaskets for Flanged Meters

For F-5100 Inline Thermal Mass Flow Meters provided with ANSI class 150 or class 300 flanges require gaskets for proper installation. ONICON does not supply gaskets. Gaskets used must comply with all relevant AGA and ANSI standards.

## 1.5 WORKING ENVIRONMENT

F-5000 series meters are designed for installation and use in typical industrial environments that are free of corrosive liquids and fumes, direct liquid exposure, heavy condensation, temperature extremes and vibrations. Do not install the meter in direct sunlight.

The operating ambient air temperature range is -5° to 150° F.

The electrical power should be relatively clean, free of high frequency noise, large voltage transients, and protected from power surges and brown outs.

## 1.6 WARRANTY & SERIAL NUMBER



### IMPORTANT NOTE

ONICON F-5000 series flow meters are individually calibrated. Remote mount electronics enclosures and sensors must share the same serial number and must be installed together as a system. Mixing components from different meters will result in significant errors in calibration.

### Warranty

ONICON provides a 2-year warranty for this product. Certain exclusions apply. Please refer to Appendix A-3, ONICON's Terms and Conditions of Sale for details.

### Serial Number

The serial number of your F-5100 series flow meter is located on the nameplate attached to the top of the enclosure. This serial number will also be located on the remote sensor for remote mount meters.

## **SECTION 2.0: UNPACKING**

ONICON Insertion Thermal Mass Flow Meters are packed and shipped in individual cartons. All other peripheral devices will be packaged and shipped separately.

Please open all packages with care to prevent damage to their contents. Carefully inspect each item for signs of damage in transit.

All ONICON products are shipped insured unless the customer specifically requests otherwise. Please notify the shipping company and ONICON Customer Service immediately if any items are damaged in transit. Save all packing material for inspection by the shipper.

### **2.1 CHECKING TO SEE THAT YOU RECEIVED EVERYTHING**

#### **Standard Documentation**

Enclosed with each meter is a comprehensive documentation package that includes the following items:

- Installation and Operation Guide
- Flow Meter Calibration Certificate
- Product Data Sheet

Please notify the ONICON customer service department if any of these documents are missing.

#### **Product**

- F-5100 Inline Thermal Mass Flow Meter

## SECTION 3.0: INSTALLATION

### WARNING



This flow meter may be installed in pipes which are under high pressure or pipes filled with combustible gases. Accidents with these systems can cause serious injury or death. Only persons experienced with high pressure and/or combustible gas distribution systems and fluid metering should attempt to install, adjust, or remove the flow meter. Please read all instructions carefully before attempting to install or service a flow meter.

ONICON will be happy to assist with technical recommendations and to provide guidance by phone or e-mail. On-site field engineering, installation and service are also available at an additional cost.

### 3.1 INSTALLATION SITE SELECTION

Install the flow meter where it will be accessible for personnel to perform necessary periodic maintenance. The clearance required for installation is a minimum of 9" from the pipe wall to the nearest obstruction above the electronics enclosure. Refer to Section 1.5 WORKING ENVIRONMENT for additional considerations.

ONICON inline style flow meters must also be correctly oriented in the pipe with respect to the direction of flow. On meters with an integrally mounted display, this will affect the orientation of the display.

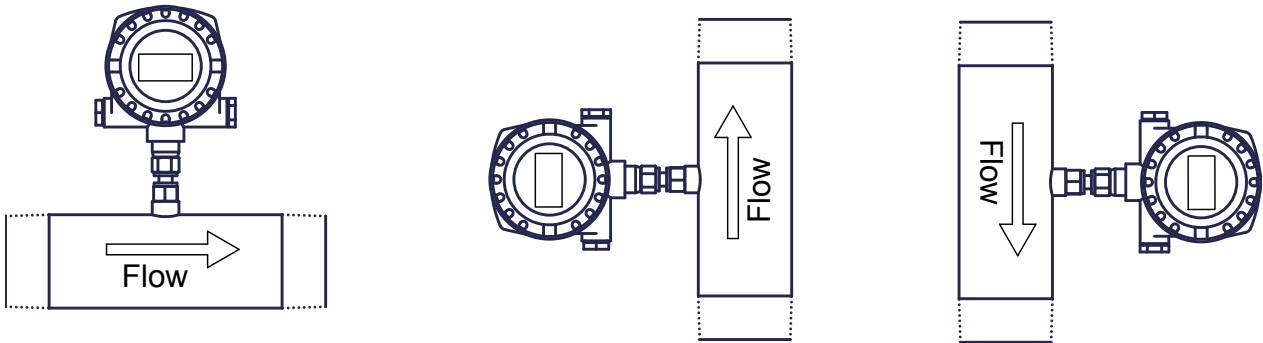

The drawings above illustrate the relationship between the integral display, the flow direction and the orientation of the meter when installed in the pipe. Contact ONICON for assistance if this relationship does not allow for viewing the display.

#### GENERAL PRACTICES:

1. For best results, install the flow meter in a straight run of pipe, free of bends, tees, valves, transitions and obstructions.
2. Straight run requirements vary based on the nature of the upstream obstruction. See the table on page 12 for guidelines in determining upstream straight run requirements. Depending upon specific location details, more or less straight run may be required to produce a satisfactory flow profile.
3. If there is insufficient straight run, allow 80% of the run upstream and 20% of the run downstream. If the total length of straight run is less than 75% of the recommended distance, performance may seriously degrade.

## How to Determine the Available Straight Pipe Run:

**Locate the longest straight unobstructed section of pipe available. To be unobstructed, the section of pipe must be free of bends, tees, size transitions, valves or insertion probes of any kind.**

In addition to the information provided above and on the previous page, the diagrams shown below and the table shown on the next page should be used as a guide to identifying the best installation location for the meter.

Required upstream/downstream distances in inches as measured from the process connections.

### EVALUATING UPSTREAM PIPING CONDITIONS

- |   |                                |
|---|--------------------------------|
| ↑ | Better                         |
| ↓ | Worse                          |
| ↑ | Straight Pipe                  |
| ↓ | Single Bend                    |
| ↓ | Pipe Reduction                 |
| ↓ | Multiple Bends in Same Plane   |
| ↓ | Pipe Expansions                |
| ↓ | Tees                           |
| ↓ | Multiple Bends Out of Plane    |
| ↓ | Modulating or Regulating Valve |

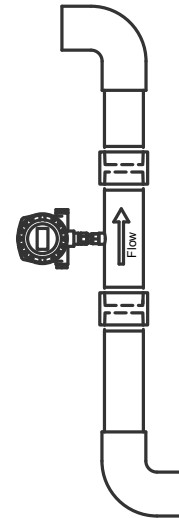
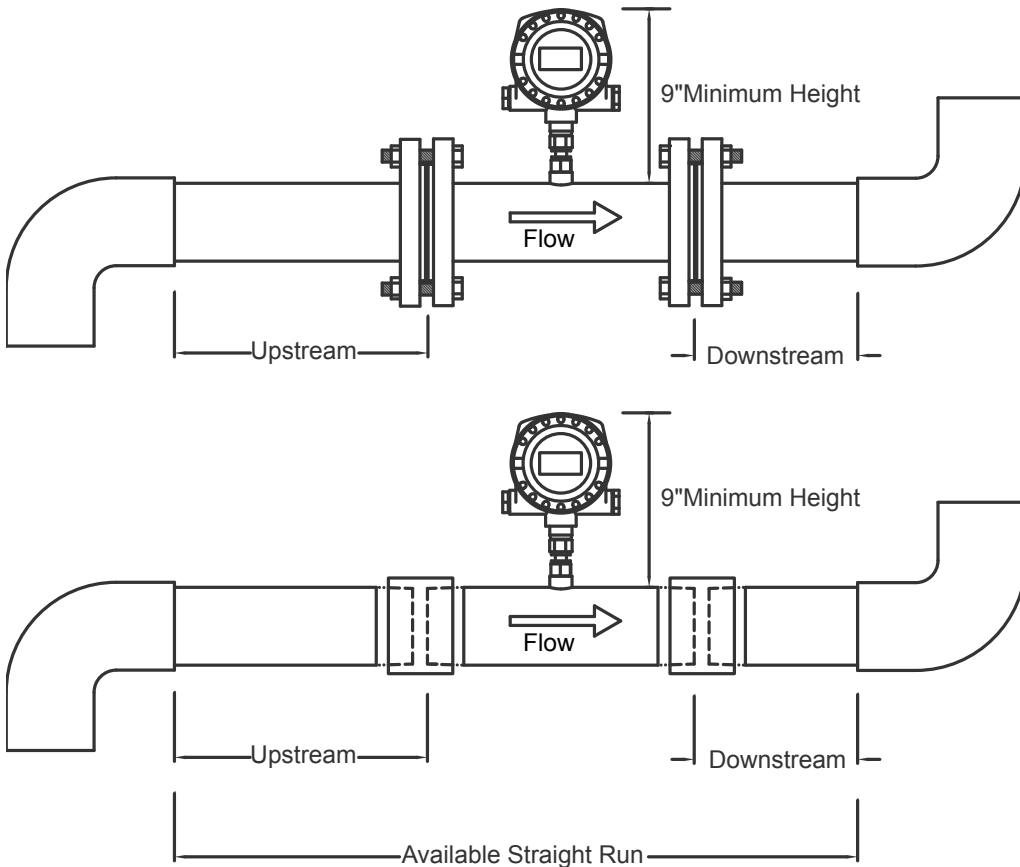

Meter may be installed in a vertical pipe with upward or downward flow

Minimum Straight Run required upstream of flow meter process connection based on the nature of the upstream obstruction.						
Upstream Obstructions	Single bend preceded by $\geq 9$ diameters of straight pipe Or Pipe size reduction in straight pipe run	Multiple bends in plane with $< 9$ diameters of straight pipe between them Or Pipe size expansion in straight pipe run	Tees	Multiple bends out of plane	Modulating or Regulating valves	Minimum Downstream Straight Run Required After Flow Meter Process Connection
Nom. Dia.						
1/4"	None	2"	5"	5"	7"	None
3/8"	1"	1"	6"	6"	12"	None
1/2"	None	None	None	1"	2"	None
3/4"	None	None	1"	4"	4"	1"
1"	None	None	1"	5"	6"	1"
1 1/4"	None	None	2"	7"	8"	2"
1 1/2"	None	None	2"	8"	9"	2"
2"	None	None	4"	12"	14"	4"
2 1/2"	2"	2"	7"	17"	19"	7"
3"	3"	3"	9"	21"	24"	9"
4"	4"	4"	12"	28"	32"	12"

#### IMPORTANT NOTICE



Always use the maximum available straight run. When more than the minimum required straight run is available place the meter such that the excess straight run is upstream of the meter location.

The flow meter must also be properly installed with respect to the direction of flow. Installing the meter with the flow arrow pointing in the wrong direction will result in significant errors in the flow measurement.

## 3.2 MECHANICAL INSTALLATION

ONICON Inline Thermal Mass Flow Meters are provided with either threaded or flanged process connections. Threaded meters are provided with male NPT threads and flanged meters are provided with ANSI class 150 or class 300 flanges. Flow meters should be installed in accordance with the requirements of section 3.1 INSTALLATION SITE SELECTION.

ONICON does not supply gaskets for flanged meters.

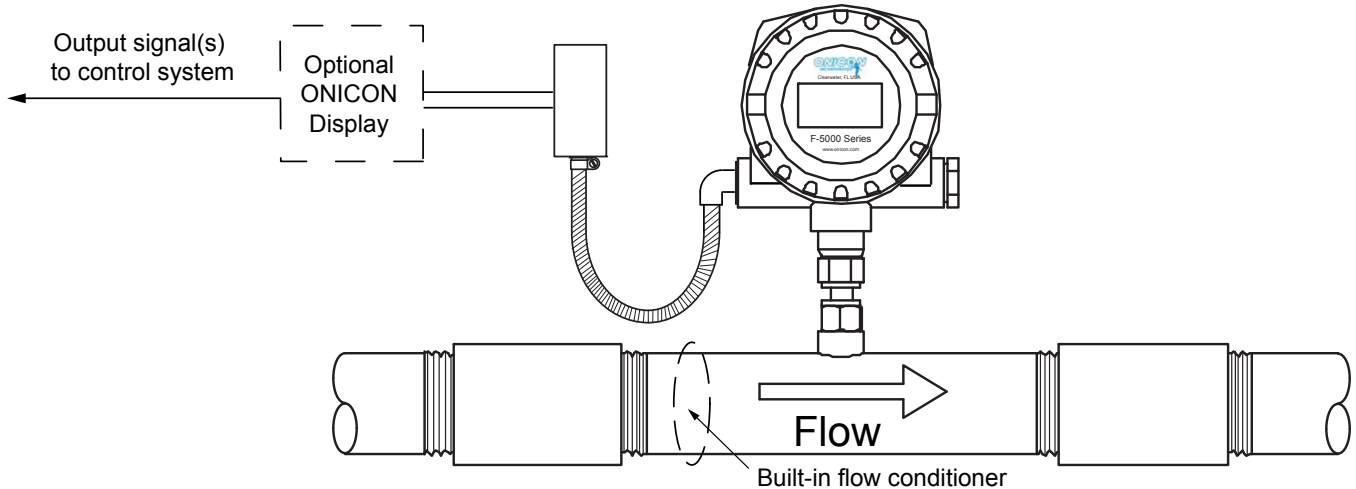

### 3.2.1 Threaded Meter

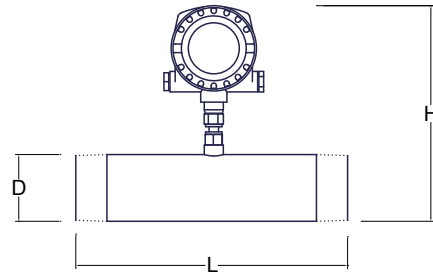

**Threaded inline sensor dimensions (inches)**

	1/4	3/8	1/2	3/4	1	1 1/4	1 1/2	2	2 1/2	3	4
L	6	6	7	8	10	12	12	12	12	12	12
D	0.54	0.68	0.84	1.05	1.315	1.66	1.9	2.375	2.875	3.5	4.5
H	9.42	9.56	9.72	9.93	10.195	10.54	10.78	11.255	11.755	12.38	13.38

### Installation Instructions

1. Apply AGA approved paste sealant or tape sealant to the male NPT threads.
2. Tighten fittings as per ANSI standards for NPT pipe fittings.
3. Leak test all connections.

### 3.2.2 Flanged Meter

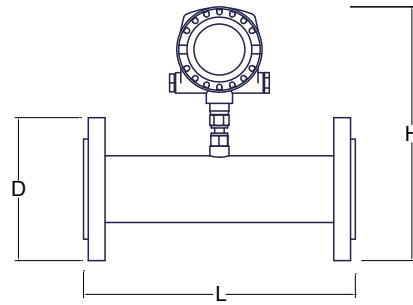

**ANSI Class 150 Flanged inline sensor dimensions (inches)**

	¼	⅜	½	¾	1	1¼	1½	2	2½	3	4
L	n/a	n/a	7	8	10	12	12	12	12	12	12
D	n/a	n/a	3.5	2.88	4.25	4.62	5	6	7	7.5	9
H	n/a	n/a	12.38	12.76	13.13	13.5	13.88	14.88	15.88	16.38	17.88

**ANSI Class 300 Flanged inline sensor dimensions (inches)**

	¼	⅜	½	¾	1	1¼	1½	2	2½	3	4
L	n/a	n/a	7	7	8	10	12	12	12	12	12
D	n/a	n/a	3.75	4.62	4.88	5.25	6.12	6.5	7.5	8.25	10
H	n/a	n/a	12.63	13.5	13.76	14.13	15	15.38	16.38	17.13	18.88

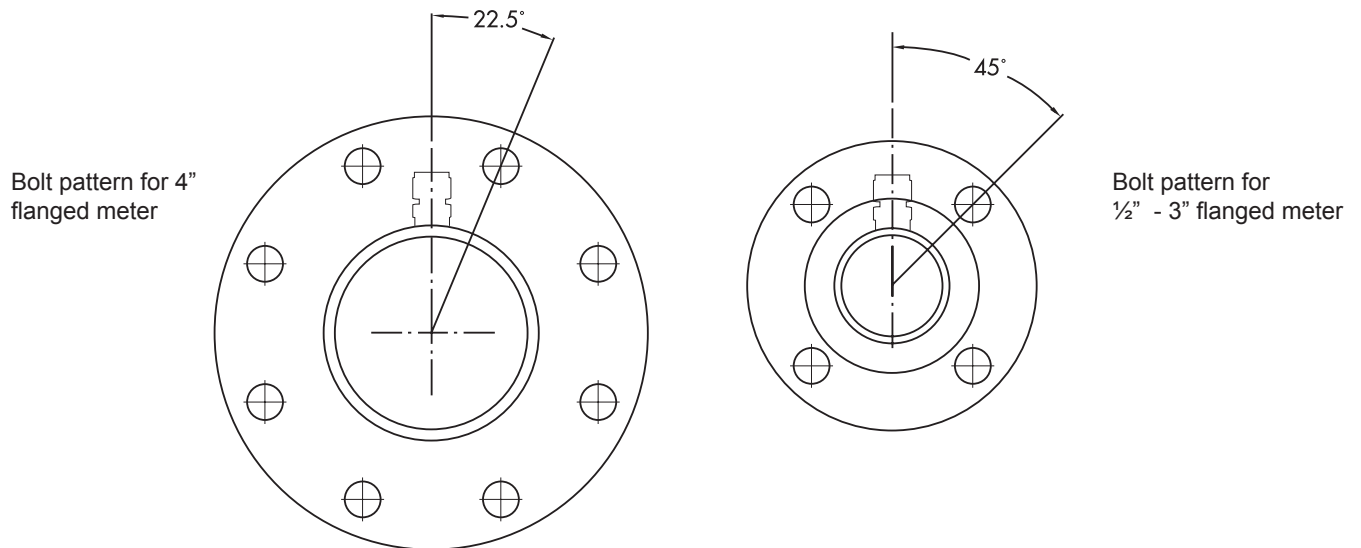

#### Installation Instructions

1. Thoroughly clean all flange surfaces removing all traces of any old gasket material or any adhesive residue.
2. Inspect all flange surfaces for warping, pitting or other surface imperfections that may prevent a good seal.
3. Use new bolts, nuts and hardened washers. Prior to installation,

lubricate the bolt threads, nuts, washer faces and the underside of each bolt head with lubricant (Fel Pro C5A or equivalent). This lubricant is necessary to ensure uniform stress distribution on the sealing surface. Use care not to get any lubricant on the gasket material.

4. Center the new gasket on the flange face. Do not allow the gaskets to protrude into the flow stream.
5. Use the torque specifications provided by the gasket manufacturer to determine the proper torque setting.
6. Using a torque wrench, tighten the bolts in at least three stages (30%, 60% & 100%) using a repeating pattern sequence of 12 o'clock to 6 o'clock to 3 o'clock to 9 o'clock around the flange as shown in the diagrams below.
7. Leak test all connections.

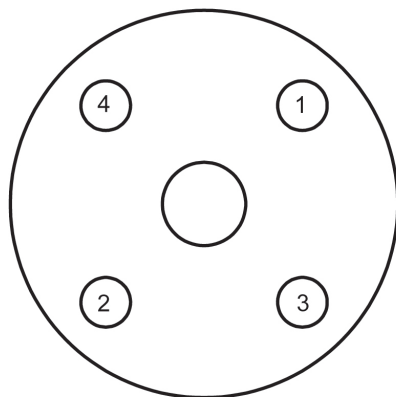

4-bolt

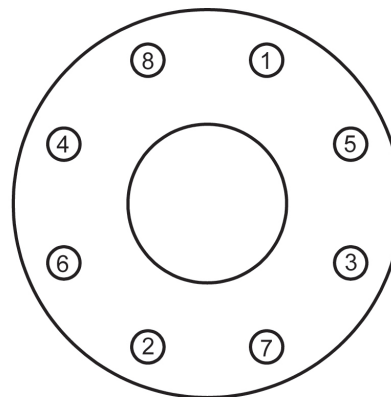

8-bolt

### Bolt Tightening Sequence

### 3.3 ELECTRICAL INSTALLATION

The electrical installation of this product must comply with all federal, state and local building codes. Connect and re-verify all output signal and safety earth wiring connections prior to connecting power.

All connections must be made through the (2) ½' NPT cable glands located on the enclosure. To access the terminal wiring connections, remove the rear cover from the enclosure.



#### CAUTION

Cable glands seals shipped with the meter are for shipping purposes only. Remove and replace with approved fittings when installing the meter.



#### WARNING

If the meter is being installed in a Class 1 hazardous location, the installation must comply with all appropriate electrical codes.



#### WARNING

The meter must be connected to a protective earth wire at the transmitter and at the sensor for remote mount meters as per electrical codes.

#### 3.3.1 Analog Output

The F-5100 is provided with a single 4-20 mA output for instantaneous rate. This output is electrically isolated from earth, but shares common with the scaled pulse output and, on DC versions of the meter, with input power.

The output is programmed at the factory. Refer to the attached laminated tag or the certificate of calibration for information regarding the programmed full scale flow. Contact ONICON for assistance if the full scale flow rate requires reprogramming.

#### 3.3.2 Pulse Output

The F-5100 is provided with a single scaled pulse output for totalizing flow. This is an active pulse output with a nominal pulse amplitude of 24VDC (12VDC for 12V versions of the meter). In all versions, the pulse duration is 500ms.

This DC pulse output is electrically isolated from earth, but shares common with the analog output and, on DC versions of the meter, with input power. This output is programmed at the factory. Refer to the attached laminated tag or the certificate of calibration for information regarding the programmed pulse value.

Contact ONICON for assistance if the scaled pulse output requires reprogramming.



#### IMPORTANT NOTICE

The nominal pulse output voltage from this meter is 24 VDC. Contact ONICON if you require a pulse output with a different voltage than the supply voltage.

### 3.3.3 Integral Mount Wiring

INSIDE REAR COVER LABEL

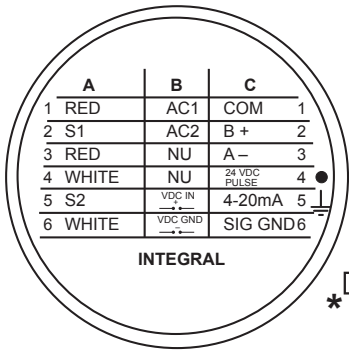

- A1 - RED - VELOCITY SENSOR WIRE (HEATED ELEMENT)
- A2 - NO WIRE
- A3 - RED - VELOCITY SENSOR WIRE (HEATED ELEMENT)
- A4 - WHITE - TEMPERATURE SENSOR WIRE
- A5 - NO WIRE
- A6 - WHITE - TEMPERATURE SENSOR WIRE

- B1 - AC1 - AC VOLTAGE
- B2 - AC2 - AC VOLTAGE
- B3 - NU - NOT USED
- B4 - 4 - 20 mA POWER
- B5 - VDC IN - VOLTAGE DC - POSITIVE (+)
- B6 - VDC GND - VOLTAGE DC - GROUND (-)

- C1 - NOT USED
- C2 - RS 485 (+)
- C3 - RS 485 (-)
- \* C4 - 24 VDC PULSE - 0 TO 24 DC PULSE OUTPUT
- C5 - 4 - 20 mA - 4 TO 20 mA ANALOG OUTPUT
- C6 - VDC GND - VOLTAGE DC - GROUND (-)

INSIDE BODY VIEW

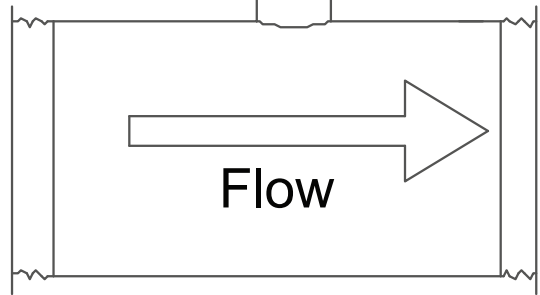
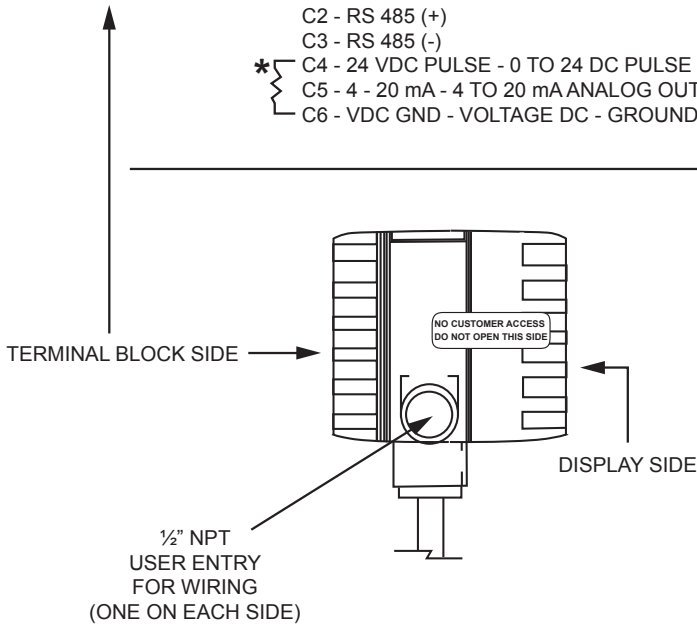
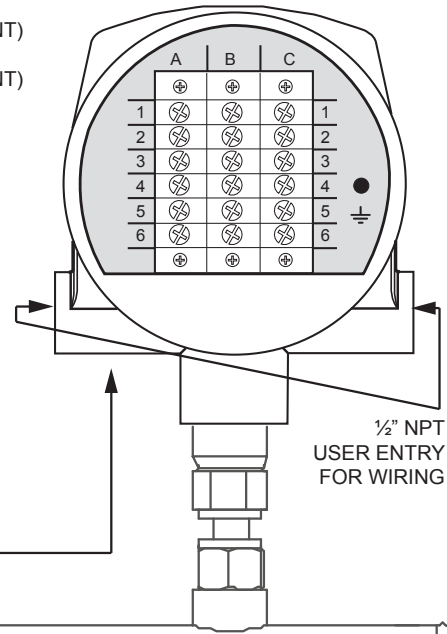

\* Factory installed jumper and resistor. Do not remove.

F-5100 Terminals

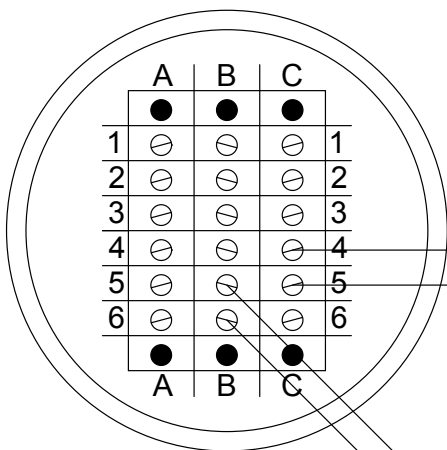

Control System

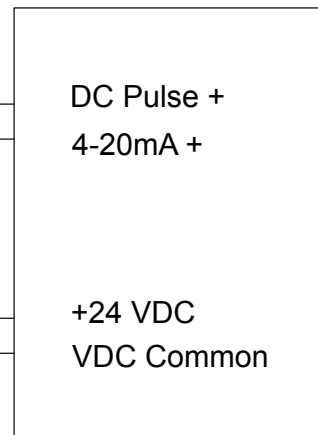

### 3.3.4. Remote Mount Wiring

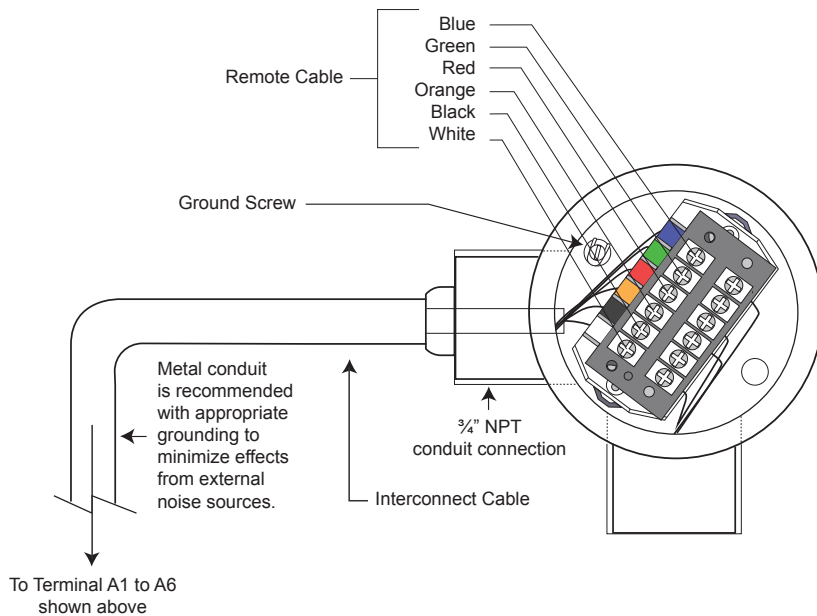
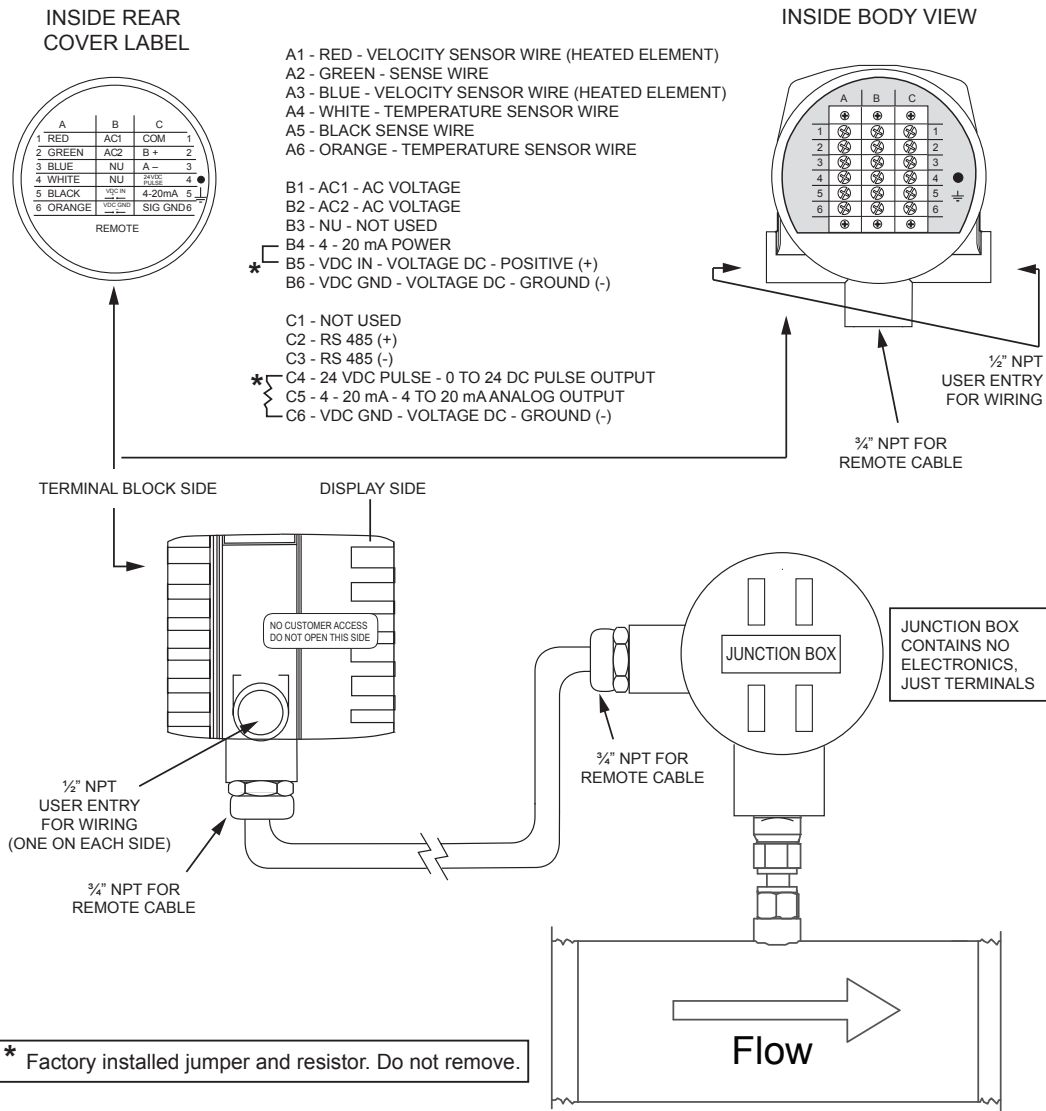

## SECTION 4.0: START-UP & COMMISSIONING FOR ONICON INLINE THERMAL MASS FLOW METERS

### 4.1 DISPLAY

The F-5100 flow meter features a bright easy-to-read graphic LED display that displays alphanumeric and graphical data.

This display is provided with a screen saver function that extends the life of the display. The display will revert to the normal display mode whenever the proximity sensor detects movement directly in front of the meter.

#### Displayed Information:

1. Energy reading used to valid calibration
2. Graphical indication of percentage of full scale flow rate
3. Flow rate
4. Flow total
5. Fluid temperature
6. Engineering units associated with flow rate and total
7. LED's for Power, Serial Communications, and Pulse Output

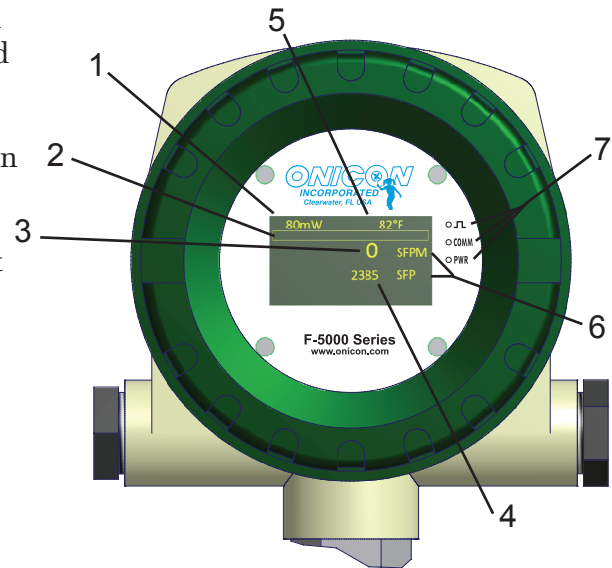

### 4.2 POWERING THE METER

Upon initial power up, the meter will indicate ONICON F-5000 Series along with the current firmware version and the serial number. Two additional messages will be displayed and then the meter will advance to the normal run mode screen. If the meter is installed in a pipe with flow, the meter will begin displaying flow and temperature data. After one minute of no movement, the screen saver message will appear.

### 4.3 HELPFUL HINTS FOR START-UP & COMMISSIONING

A step-by-step procedure and companion worksheet are located on the next two pages. Please read all installation instructions carefully before proceeding with start-up and commissioning.

Please read these helpful hints before proceeding with the start-up and commissioning procedure on the next page.

1. When measuring analog output signals, remember that current (mA) must be measured in series, while voltage is measured in parallel. If the 4-20 mA signal is already connected to a control system, you must break the connection and measure the signal in series.
2. Do not attempt to rotate the electronics enclosure on the stem.
3. Never connect power to analog or pulse output signal wires. Standard ONICON F-5100 Flow Meters are not configured from the factory as “loop powered” devices.

#### 4.4 START-UP & COMMISSIONING

Please read the entire procedure before proceeding. A worksheet for checking off the following steps and recording measured values is located on the next page.

1.	Confirm flow meter location.  Confirm adequate straight pipe run to achieve desired results.	Is the meter located in the correct location as required by the plans?  Compare actual straight pipe upstream and downstream of the meter location to recommended distances identified in this manual.
2.	Confirm orientation.	Refer to the information in section 3.1 of this manual to ensure that the meter is properly oriented with respect to the direction of flow.
3.	Confirm control system programming.	Confirm that the control system input point is properly configured for the analog range and/or scale factor identified on the calibration tag & certificate.
4.	Confirm connection to correct ONICON display	Confirm that the flow meter serial number matches the ONICON display (when ordered together).
5.	Verify wiring before connecting power.	Prior to connecting the power, verify that the wiring is correct as shown in this manual and/or on additional wiring diagrams provided with the ONICON display. If in doubt, contact ONICON for assistance before proceeding further.
6.	Confirm correct supply voltage.	Verify that the supply voltage matches the voltage listed on the meter tag.
7.	Connect power.	Wait approximately 45 seconds after power-on before proceeding further.
The following steps require flow in the pipe. Flow signal readings should be taken while holding the flow rate constant, if possible. Otherwise, take the various output readings as quickly as possible.		
8.	Measure and record analog and pulse outputs.  Current Output:  Scaled Output:	Refer to flow meter wiring diagram to locate the correct output terminals. Use the following formula to calculate the flow rate from the analog signal measurement:  $SCFM = \frac{(\text{measured current in mA} - 4) \times \text{Full Scale Flow Rate}}{16}$ Each 24VDC pulse = unit volume identified as "Scale Factor" (measure and record time interval between pulses)
9.	Compare output signals to each other and to the flow rate displayed by the control system.	Compare the flow rate calculated in step 8 to the flow rate indicated by the control system. Confirm that the control system is registering scaled output pulses as they occur.  Refer to troubleshooting guide when readings are inconsistent.

## 4.5 START-UP & COMMISSIONING WORKSHEET

Please read all installation instructions carefully prior to proceeding with these steps. Use the following worksheet for checking off the commissioning steps and recording measured values.

STEP	TEST/MEASUREMENT	S/N:	S/N:	S/N:	S/N:
1.	Meter location:				
2.	Confirm pipe size:				
3.	Confirm orientation:				
4.	Control system programming:				
5.	Match display serial number (S/N) if ordered:				
6.	Signal connections verified:				
7.	Supply voltage verified:				
8.	Connect power:				
<p>The following steps require flow in the pipe. Flow signal readings should be taken while holding the flow rate constant, if possible. Otherwise, take the various output readings as quickly as possible.</p>					
9.	Analog or pulse output(s)				
	4 - 20 mA signal:	_____ mA	_____ mA	_____ mA	_____ mA
	Scaled output interval:	_____	_____	_____	_____
	Calculated flow rate:	_____ SCFM	_____ SCFM	_____ SCFM	_____ SCFM
10.	Flow rate displayed by control system:	_____ SCFM	_____ SCFM	_____ SCFM	_____ SCFM

## **SECTION 5.0: TROUBLESHOOTING GUIDE**

NOTE: Also refer to the START-UP AND COMMISSIONING GUIDE located on page 18.

<b>REPORTED PROBLEM</b>	<b>POSSIBLE SOLUTIONS</b>
No signal	<ul style="list-style-type: none"><li>• Verify that the meter is properly installed in the pipe.</li><li>• Verify that the flow direction arrow is pointing in the right direction.</li><li>• Verify supply voltage.</li><li>• Verify correct wiring to control system (see wiring diagram).</li><li>• Verify that there is flow in the pipe.</li><li>• Please contact ONICON for further assistance.</li></ul>
Reading is too high or low	<ul style="list-style-type: none"><li>• Verify that the meter is properly installed in the pipe.</li><li>• Verify that the flow direction arrow is pointing in the right direction.</li><li>• Verify correct wiring to control system (see wiring diagram).</li><li>• Confirm that the control system is programmed for correct flow range or pulse scale factor.</li><li>• Verify that the meter cable shield is connected to earth at the control system. Lack of proper shielding can lead to excessive noise that can affect the flow reading.</li><li>• Verify that the meter is connected to earth.</li><li>• Check for ground loop or offset voltage:</li><li>• Disconnect analog signal input from control system and measure analog output directly from the flow meter.</li><li>• Reconnect signal input to control system and measure the analog signal again. Any difference between these readings indicates a potential ground loop or offset voltage.</li><li>• Meter is being used to measure flow of a different gas or gas mix than the meter was specified and calibrated for.</li><li>• Please contact ONICON for further assistance.</li></ul>
Erratic readings	<ul style="list-style-type: none"><li>• Confirm that the meter is connected to earth and all cabling is properly shielded.</li><li>• Please contact ONICON for further assistance.</li></ul>

REPORTED PROBLEM	POSSIBLE SOLUTIONS
<p>Meter will not communicate with the network controller.</p>	<ul style="list-style-type: none"> <li>• Is the Transmit LED flashing on the display? The Transmit LED will only flash when the device is responding to a poll. A unique address is required for each device on the network. Duplicate addresses will cause some or all of the devices on the network to quit working. (See section 1.6.1 of this manual for details.)</li> <li>• The RS485 network cable connections are polarity sensitive and must be connected the same way on every device (i.e. + to + and - to -). (See section 1.4.1 of this manual for details.)</li> <li>• The Baud rate setting must match the network Baud rate. (See section 1.5.1 of this manual for details.)</li> <li>• Shield drain connections should be daisy chained in the same manner as the signal cables for RS485. The shield drain wire should be left unterminated at the end of the cable and connected to earth only at the network master controller. Shield wires must not be connected to the RS485 connector on the System-10.</li> <li>• The maximum number of devices allowed on a RS485 network segment without a repeater is 32. Adding more than 32 devices to a single segment may reduce the transceiver output voltage to a level that is too low to be distinguished from background noise on the cable.</li> <li>• RS485 cable impedance should be matched to a termination resistor at the end of the cable. This resistor should only be used if the display is the last device on the network cable. (See section 1.5.2 of this manual for details.)</li> </ul>

<p>Network communications are disrupted when the device is connected.</p>	<ul style="list-style-type: none"><li>• The RS485 network cable connections are polarity sensitive and must be connected the same way on every device (i.e. + to + and - to -). (See section 1.4.1 of this manual for details.)</li><li>• Is the transmit LED flashing? The transmit LED will only flash when the device is responding to a poll. A unique address is required for each device on the network. Duplicate addresses will cause some or all of the devices on the network to quit working. (See section 1.6.1 of this manual for details.)</li><li>• Shield drain connections should be daisy chained in the same manner as the signal cables for RS485. The shield drain wire should be left unterminated at the end of the cable and connected to earth only at the network master controller. Shield wires must not be connected to the RS485 connector on the F-5100.</li></ul>
---	---

## **APPENDIX**

A-1 REMOTE MOUNT MECHANICAL HARDWARE

A-2 CONDITIONS OF SALE

A-3 USE OF THE INSERTION DEPTH GAGE

## MOUNTING OPTIONS

1. Overhead with U-bolts (customer supplied) across pipe on each leg
2. Vertically, as shown
3. Horizontally

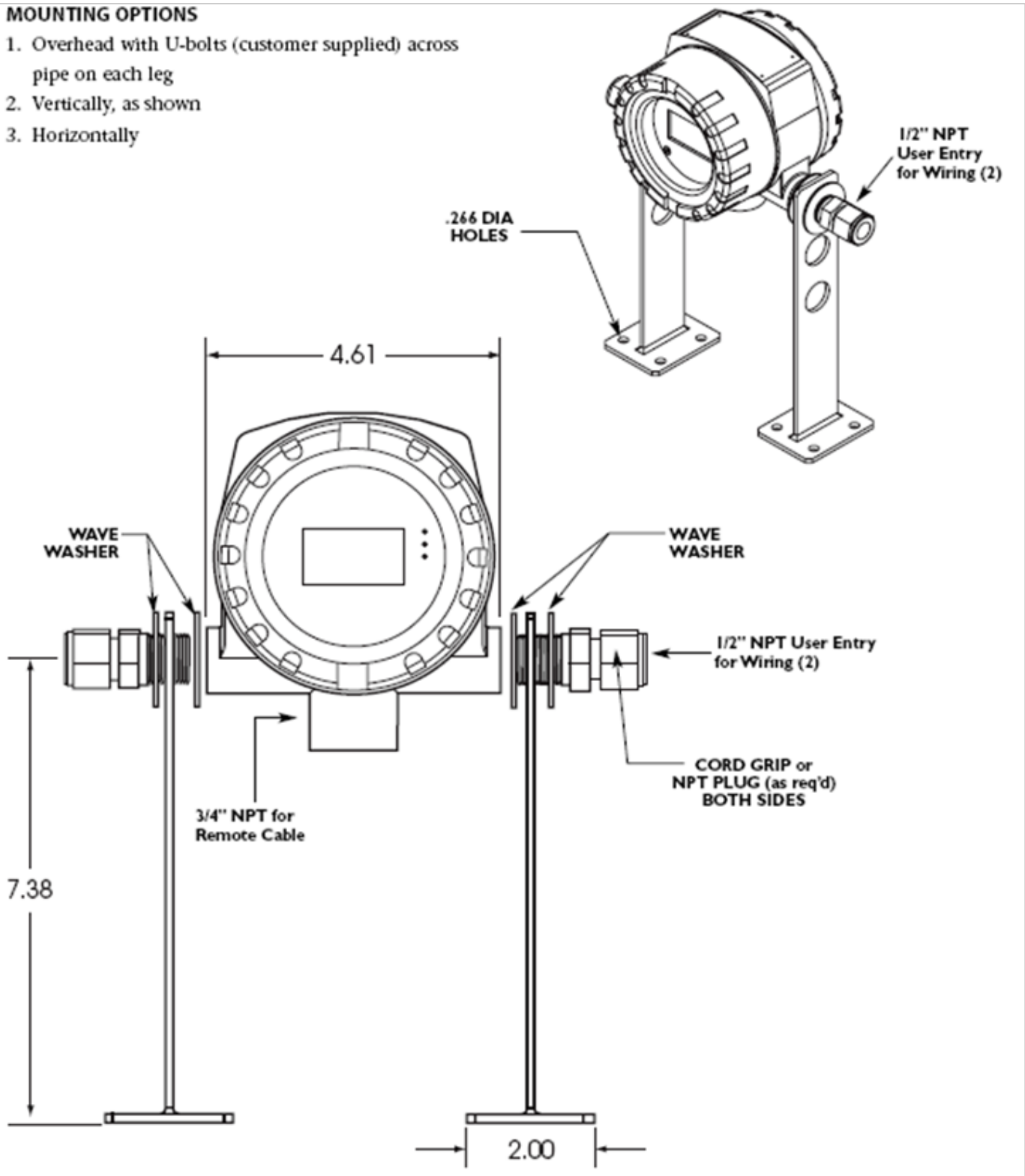

## Terms and Conditions

1. **ACCEPTANCE:** The following Conditions of Sale apply to all sales of ONICON's products. These provisions shall apply even if ONICON fails to object to provisions appearing on, incorporated by, referenced in, or attached to Buyer's purchase order form. Buyer's acceptance of delivery of ONICON's products constitutes its acceptance of these Conditions of Sale.
2. **DELIVERY AND TITLE:** All product shipments are F.O.B. shipping point and title passes to the Buyer at the time ONICON delivers the merchandise to the carrier. Risk of loss or damage to the product passes to the Buyer at the time ONICON delivers the product to the carrier. The Buyer immediately upon receipt should inspect all shipments, and should there be any evidence of damage or loss in transit, Buyer must file claims or tracers upon carrier. ONICON will assist in tracing shipments upon request.
3. **LIMITED WARRANTY:** ONICON warrants that for a period of two (2) year following the date of original shipment of an ONICON product: (i) the product will conform to ONICON's standard written specifications applicable to such product in effect on the date of Buyer's order, or as modified by ONICON's quotation or Buyer's purchase order accepted by ONICON, (ii) the product will be free from defects in workmanship, and (iii) that ONICON has title to the product prior to shipment to the Buyer; provided, however, that the warranties provided herein shall be void and may not apply in the event Buyer misuses or damages a product, including, but not limited to, any use by the Buyer of a product for an application other than one of a type approved by ONICON. ONICON's sole liability and Buyer's sole remedy for any breach of the foregoing warranty is for ONICON to repair or replace, at ONICON's option, any defective product that is returned to ONICON during the warranty period. EXCEPT AS MAY BE SPECIFICALLY AGREED BY ONICON IN WRITING IN RELATION TO EACH SALE, NO OTHER WARRANTIES SHALL APPLY, WHETHER EXPRESSED, IMPLIED OR STATUTORY, AND THERE SHALL BE NO IMPLIED WARRANTIES OF MERCHANTABILITY AND FITNESS FOR A PARTICULAR PURPOSE.
4. **REMEDIES:** ONICON's OBLIGATION UNDER THE FOREGOING WARRANTIES IS LIMITED SOLELY TO REPAIR OR REPLACEMENT, AT ONICON's OPTION, OF DEFECTIVE OR NONCONFORMING PRODUCTS. ONICON SHALL NOT BE LIABLE FOR CONSEQUENTIAL, INDIRECT, PUNITIVE, INCIDENTAL, OR SPECIAL DAMAGES WHETHER FOUND ON CONTRACT, TORT OR ANY OTHER THEORY OF LAW. No products shall be returned to ONICON without its prior consent and transportation and insurance costs shall be prepaid. Any repair or replacement of ONICON's products under the foregoing warranty will be at no charge to the Buyer provided such repair is done at the ONICON factory or authorized service center. ONICON products that are repaired or replaced under this warranty will be returned to Buyer via the same method of shipment use to return the product to ONICON. Repair or replacement of ONICON products is conditioned upon ONICON's acknowledgement of any alleged defect or nonconformance during the warranty period and issuance of a Return Authorization number. All product returns must reference the Return Authorization number on the outside of the shipping carton and on any paperwork referencing the return.
5. **PRICES AND PAYMENT TERMS:** The prices set forth in the most recent quote or acknowledgement as applicable, supersede all previous prices or quotations. All quotations are subject to change or withdrawal without notice except as may be specifically noted on the face of the quotation. The prices shown do not include sales, excise or government charges payable by ONICON to Federal, State, or local authority. Any such tax or charge now or hereafter imposed upon the sale or shipment of the products under this contract will be added to the purchase price. Buyer agrees to reimburse ONICON for such tax or charge or provide ONICON with an acceptable exemption certificate. Payment of invoices will be due 30 days from the date of shipment of the products contained therein. In the event that payment of an invoice is not received by the invoice due date, ONICON will assess a late fee not to exceed 1.5% per month or 18% per year, or the maximum allowable by law whichever is lower.
6. **CANCELLATION:** Buyer may cancel its order, or any part of it, by sending written notice of cancellation to ONICON and paying a reasonable cancellation fee as determined by ONICON. The reasonable cancellation fee will reflect, among other factors, the expenses already incurred and commitments made by ONICON, sales and administrative costs and profit as determined by ONICON. If Buyer received a reduced price based on the quantity of products ordered, but has not purchased the applicable quantity at the time of cancellation, Buyer will pay the price it would have paid had ONICON's sale price been based on the quantity actually purchased.
7. **CHANGES:** If Buyer makes any changes in its drawings, designs, or specifications applicable in any contract with ONICON that cause an increase or decrease in the cost of performance of the contract, or if such changes result in rework or obsolescence, an equitable adjustment shall be made to the contract. Such changes are subject to ONICON's prior written consent.
8. **EXCUSABLE DELAY:** ONICON shall under no circumstance be responsible for failure to fill any order or orders when due to: fires, floods, riots, strikes, freight embargoes or transportation delays, shortage of labor, inability to secure fuel, material supplies, or power at current price or on account of shortages thereof, acts of God or of the public enemy, any existing or future laws or acts of the Federal or State Government (including specifically, but not exclusively, and orders, rules or regulations issued by any official or agency of any such government) affecting the conduct of ONICON's business with which ONICON in its judgment and discretion deems it advisable to comply as a legal or patriotic duty, or due to any cause beyond ONICON's reasonable control.
9. **PATENTS:** ONICON shall defend all suits or proceedings brought against Buyer or its customers arising from claimed infringements of any patent, trademark, service mark or copyright for any product furnished by ONICON and shall indemnify it against all costs, fees, and damages on the condition Buyer promptly notifies ONICON in writing and provides information and assistance to enable ONICON to conduct the defense, provided that ONICON shall have no such obligation in case of infringement resulting from ONICON's conformance to special requirements of Buyer. If ONICON is not able to settle any such suit or proceeding on acceptable terms, ONICON may, at its option, require return of the infringing product and refund the purchase price to Buyer less a reasonable allowance for depreciation or use.
10. **FAIR LABOR STANDARDS ACT:** ONICON represents that all products delivered under this contract are furnished in accordance with the applicable provisions of the Fair Labor Standards Act as amended.
11. **APPLICABLE LAW:** This document and any resulting contract shall be governed by and construed in accordance with the laws of the State of Florida. The courts of the State of Florida and the federal courts located in Florida shall have jurisdiction and venue with respect to litigation to this contract. In the event of litigation, the prevailing party shall be entitled to recover attorney's fees and costs from the non-prevailing party, including appellate attorney's fees.
12. **MODIFICATIONS:** These Conditions of Sale along with the prices, quantities, delivery schedules and other provisions and instructions in applicable quotations by ONICON or Buyer's purchase orders accepted by ONICON shall constitute the entire agreement between ONICON and Buyer pertaining to any resulting contract. They can be modified only in writing.