

**D-100 FLOW DISPLAY**  
**Johnson Controls Metasys® N2**  
**Network Interface Installation and Operation Guide**





# TABLE OF CONTENTS

1.0	INTRODUCTION .....	5
1.1	PURPOSE OF THIS GUIDE .....	5
1.2	TYPICAL D-100 NETWORK INTERFACE MODULE .....	5
1.3	SPECIFICATIONS .....	5
1.4	NETWORK SIGNAL CONNECTIONS.....	6
1.4.1	RS485.....	6
1.4.2	Optional Network Interface with Isolated Auxiliary Pulse Input .....	7
1.5	RS485 BIASING AND TERMINATION.....	10
1.5.1	Biasing and Termination.....	10
1.6	NETWORK ADDRESSING.....	10
1.6.1	Changing the Device Address.....	10
2.0	POINT FILE (.ddl).....	12
2.1	UNIDIRECTIONAL FLOW POINT INFORMATION.....	12
2.2	BIDIRECTIONAL FLOW POINT INFORMATION.....	12
2.3	VOLUME OR MASS RATE (AI2) .....	13
2.4	VOLUME OR MASS TOTAL (ADF2 & ADF4).....	14
2.5	GENERIC ANALOG INPUT(S) (AI3 & AI4) .....	15
2.6	SAMPLE .ddl FILE.....	16
3.0	NETWORK TROUBLESHOOTING TIPS .....	18
3.1	TROUBLESHOOTING .....	18

## APPENDIX

### A-1 D-100 PROCESSOR BOARD



## SECTION 1: INTRODUCTION

### 1.1 PURPOSE OF THIS GUIDE

The purpose of this guide is to provide installation and commissioning procedures and basic installation and operating instructions for the ONICON D-100-N2 Display Module serial interface.

### 1.2 TYPICAL D-100 NETWORK INTERFACE MODULE

The D-100 is a totalizing display module that provides a local indication of liquid, gas or steam flow rate and total data. It can also be provided with an optional Metasys® N2 serial interface to communicate data to the building control network.

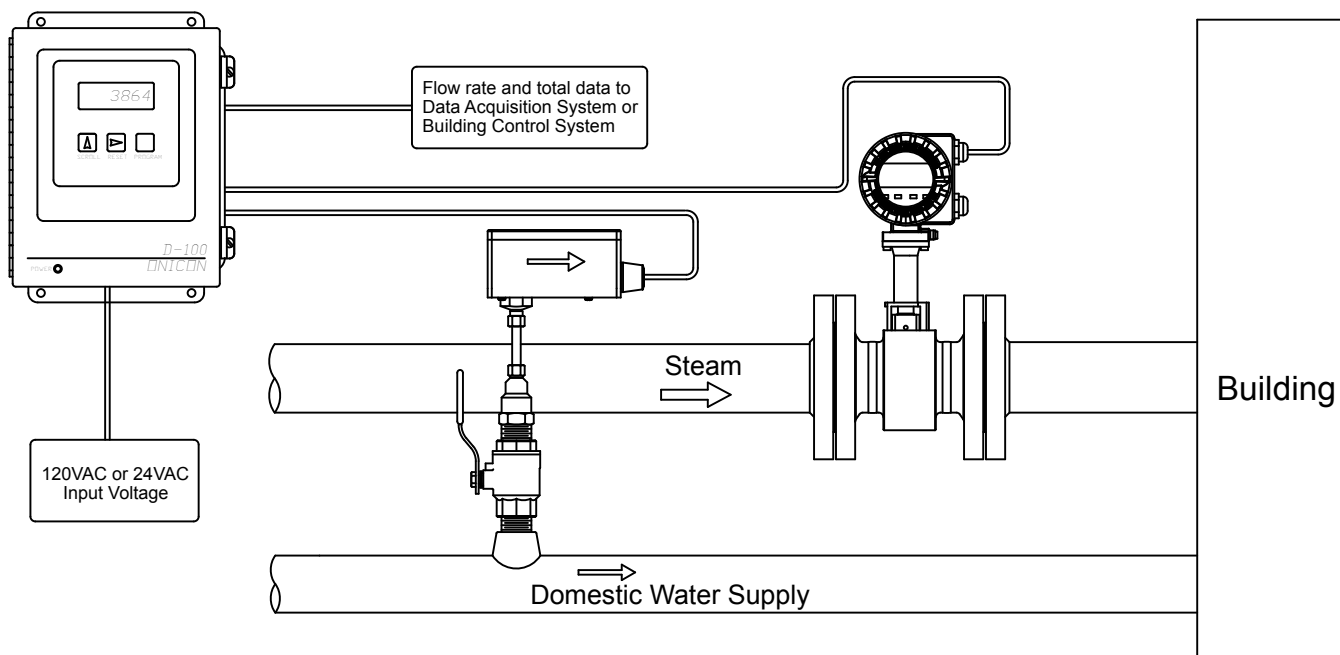

### 1.3 SPECIFICATIONS

#### METASYS® N2 NETWORK INTERFACE N2 RS485

Transceiver: 2-wire, half-duplex  
Device address range: 1 – 255 (Default: 017)  
Baud rate: 9600  
Termination: none  
Biasing: none

## 1.4 NETWORK SIGNAL CONNECTIONS

### 1.4.1 RS485

N2 RS485, 2-wire (half-duplex) serial output connections are connected to terminal as shown. Do not exceed 4.4 in-lb (0.5 Nm) of torque when tightening.



### CAUTION

Only qualified service personnel should make connections between the D-100-N2 Display and the user's external equipment. ONICON assumes no responsibility for damage caused to the external equipment as a result of an improper installation.

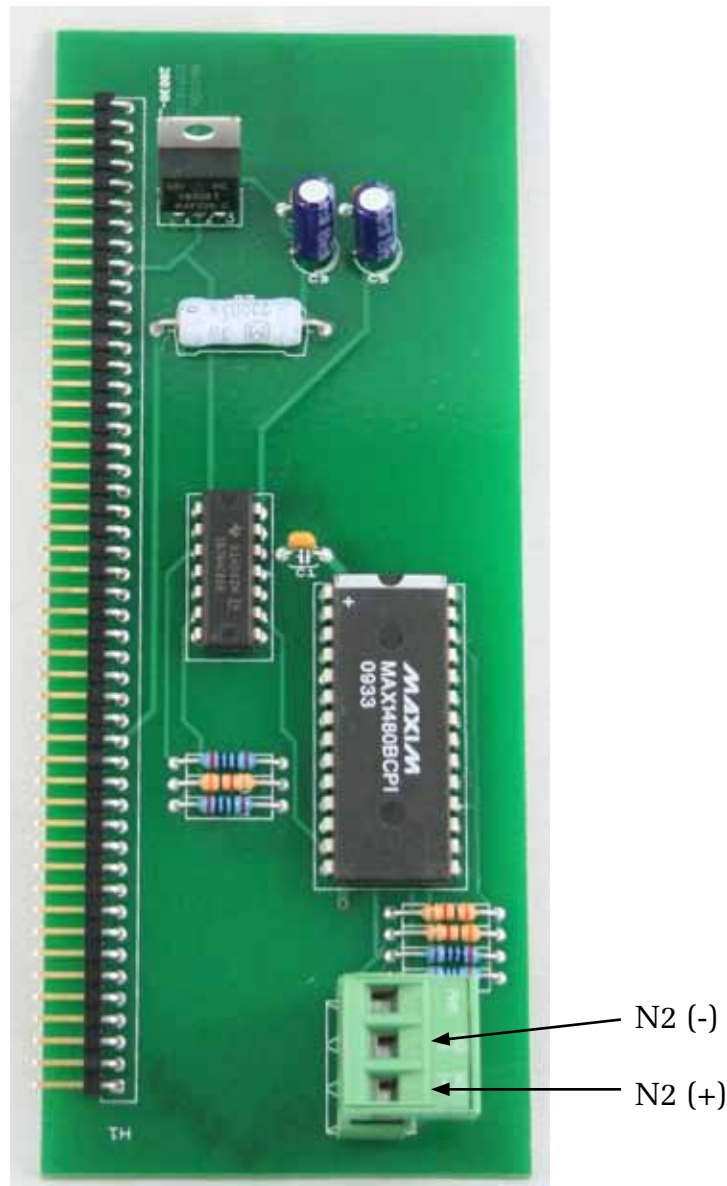

### CAUTION

Incoming and outgoing RS485 cable shield wires should be connected together, but must not be connected to the D-100.

### 1.4.2 Optional Network Interface With Optional Isolated Auxiliary Pulse Input

The D-100-N2 Display can be provided with an auxiliary input pulse for totalizing pulse outputs from external devices such as water or gas meters. Pulses are accumulated in an internal register, and the totalized value is available on the network. This register can be zeroed via the network.

If the auxiliary pulse input option was ordered at the same time the display was ordered, it will arrive fully configured and ready to use. If it was ordered after the display was delivered and is being installed as a field upgrade, it may be necessary to configure the pulse input. The information is provided below and on the following pages:

The input pulse must meet the following criteria:

1. Frequency input range, 50 Hz maximum
2. 10 millisecond minimum pulse duration

Input Pulse Definition:

In order to configure the communications card for an auxiliary input pulse, you must first determine which type of pulse your meter produces. The allowable types of input pulses are described on the following pages. Based on the type of pulse, set the selector switch (S1) on the communications circuit board (Fig. 1) to the correct setting.

Fig. 1

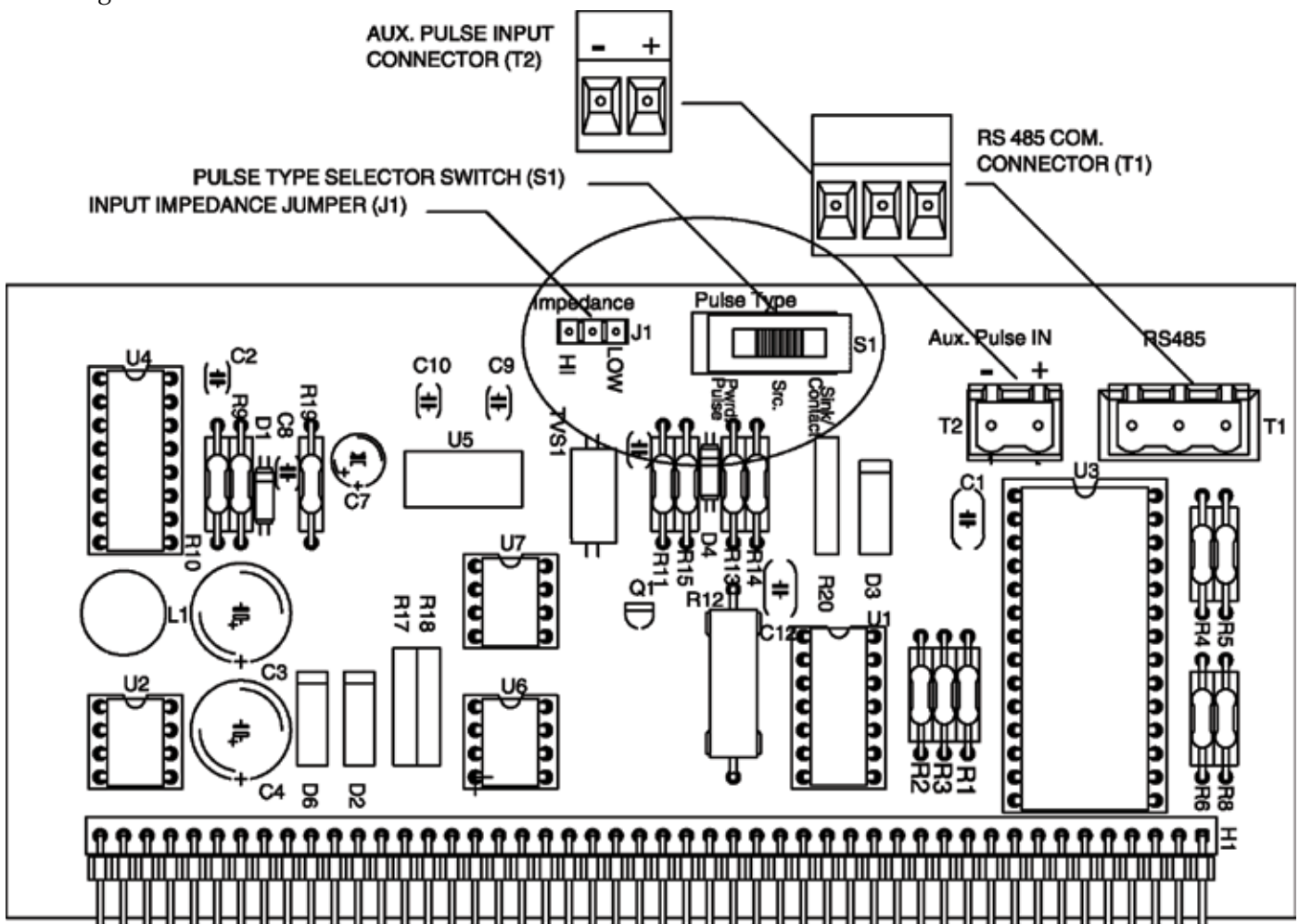

### Powered Pulse:

This type of output refers to a pulse which has an associated voltage with it (see Fig. 2). Set the selector switch, S1 to PwrD Pulse. The allowable voltage range is 5-24 VDC. The input impedance is set at the factory to be 11 KOHM via the impedance selector jumper (J1, see Fig. 1). A lower impedance, 3 KOHM can be selected if required by the instrument providing the pulse output. Consult the instrument manufacturer or ONICON if you are uncertain as to the proper jumper selection.

Fig. 2

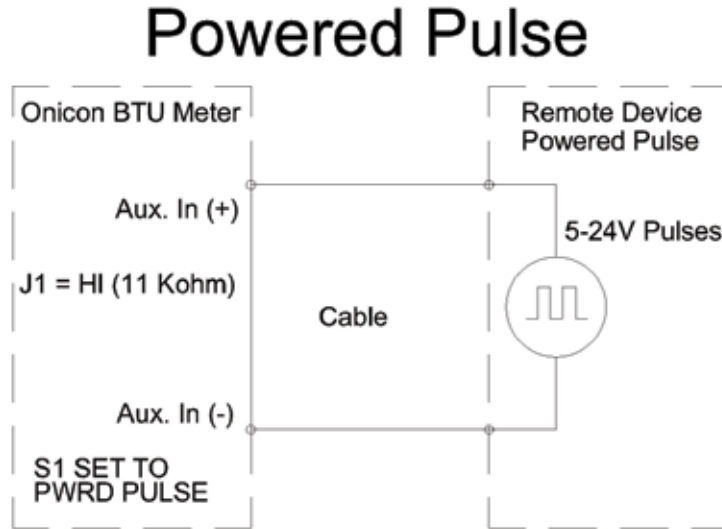

### Open Collector (Sourcing):

This type of output refers to an open Collector Switch configured for a sourcing function (see Fig. 3). Set the selector switch, S1 to SRC. The switch must be rated for at least 20mA at 20VDC.

Fig. 3

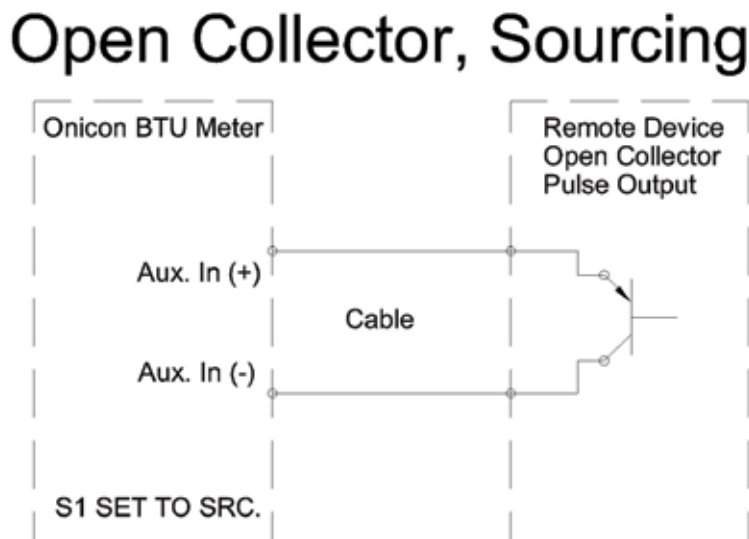

### Open Collector Sinking or Dry Contact:

This type of output refers to an open collector switch configured in a current sinking arrangement or a dry contact switch (see Fig. 4 and 5). Set the selector switch, S1 to Sink. In either case, the switch must be rated for at least 20mA at 20 VDC.

Fig. 4

## Open Collector, Sinking

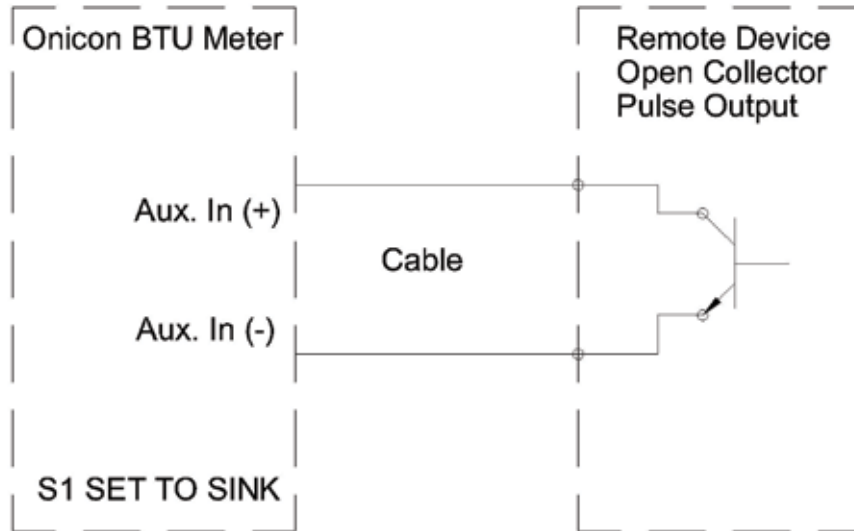
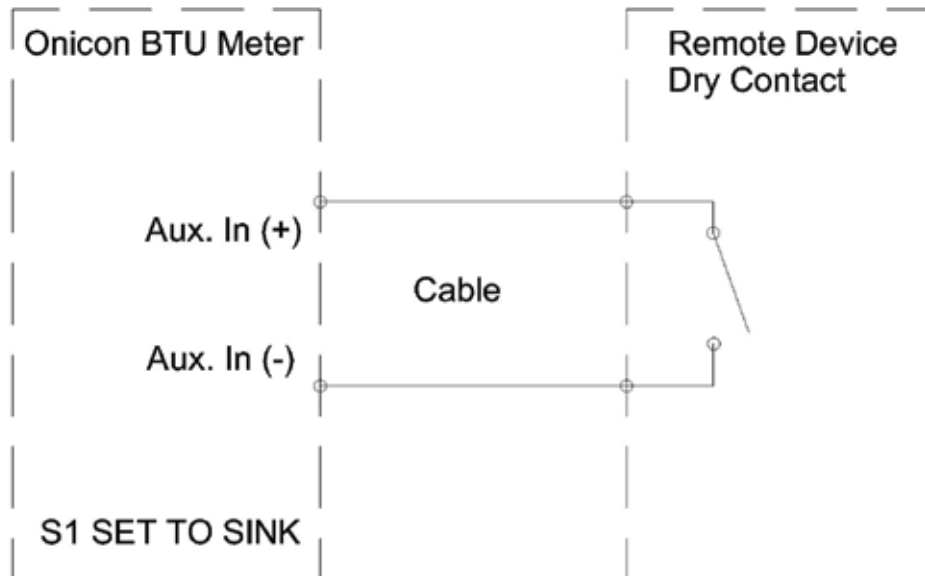

Fig. 5

## Contact Closure



## 1.5 RS485 BIASING AND TERMINATION

### 1.5.1 Biasing and Termination

The ONICON D-100-N2 does not provide biasing voltage or termination to the RS485 network. A 120Ω termination resistor should be used when the meter is installed at the end of the line.

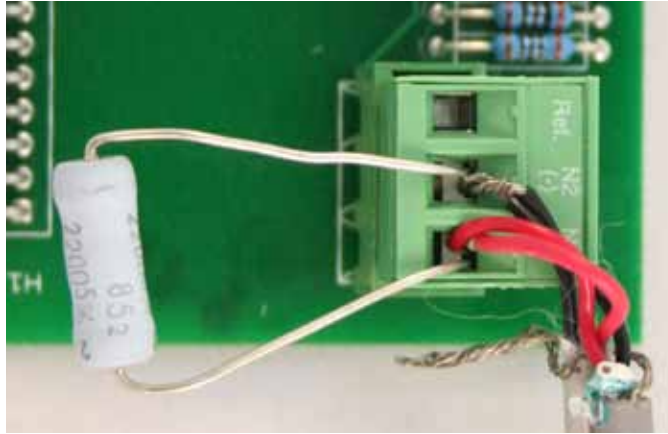

## 1.6 NETWORK ADDRESSING

Before the D-100 can communicate on the N2 network, the appropriate device address must be programmed into the display. The N2 network address for ONICON D-100 displays may be set to any address from 001 to 255. This address is set at the display. Section 1.6.1 details the procedure for changing this address.

### 1.6.1 Changing the Device Address

Every ONICON D-100 is individually programmed at the factory with application specific data provided by the customer during the ordering process, and this may include network addressing information. If the device address information was provided, the display will be programmed with that number. If no address is provided, ONICON displays are programmed with a default address of 017. The address may be changed at the D-100 using the procedure outlined in the table below.

STEP	ACTION	REACTION	COMMENT
0	Obtain a device address from the network administrator.		The device address is a three digit number between 001 - 255, excluding zero.
1	With the display running, open the front panel and locate switch DEV ADD/PROG ENAB. Press DEV ADD/PROG ENAB and then release it.	None	The DEV ADD/PROG ENAB is located in the lower left corner of the processor board. (See appendix page.)
2	Close the front panel.		
3	Press the PROGRAM button. (If you do not press the PROGRAM button, the display will revert to the RUN mode after 5 minutes.)	The D-100 changes to PROGRAM mode and the DEVICE ID page will appear with the first digit of the address flashing.	The PROGRAM button is on the front panel.
4	Successively press the SCROLL button to increment the number to the desired value from 0-9.	The number increments by one each time you press the button.	The SCROLL button is the left most button on the front panel.

<b>STEP</b>	<b>ACTION</b>	<b>REACTION</b>	<b>COMMENT</b>
5	Press the RESET button.	The second character blinks.	The RESET button is on the front panel.
6	Successively press the SCROLL button to increment the number to the desired value from 0-9.	The number increments by one each time you press the button.	The SCROLL button is on the front panel.
7	Press the RESET button.	The third character blinks.	The RESET button is on the front panel
8	Successively press the SCROLL button to increment the number to the desired value from 0-9.	The number increments by one each time you press the button.	The SCROLL button is on the front panel.
9	Once the correct value has been entered, press PROGRAM.	The FRONT PANEL RESET page appears.	It is not necessary to change anything on this page.
10	Press the PROGRAM button.	The SAVE CHANGES page appears.	The new device address must be saved to take effect.
11	Press the SCROLL button.	The N changes to Y on the SAVE CHANGES page.	The Y must be selected in order for the new address to take effect.
12	Press the PROGRAM button.	The new address is saved and the display reverts to the RUN mode.	
13	Open the front panel and locate the RESET switch. Press to reset the D-100.	When polled, the D-100 will automatically begin to communicate with the network.	RESET is located along the top of the processor board. (See appendix page.)

## SECTION 2.0: POINT FILE (.ddl)

The D-100 Display operates in one of two operating modes, unidirectional or bidirectional flow. The tables below contain point information for each operating mode.

The .ddl file contains the information that identifies the device to the N2 supervisory controller. It also specifies the variables that are available to be transmitted to and from the device on the network.

The tables below contain the .ddl information.

### 2.1 UNIDIRECTIONAL FLOW POINT INFORMATION

Point Type & Address	Engineering Units	Point Description	Range
AI2	Selectable (See volume/mass rate table)	Volume or mass rate	0-999,999
AI3	User defined	Generic analog input	0-999,999
AI4	User defined	Generic analog input	0-999,999
ADF2	Selectable (See volume/mass total table)	Volume or mass total	0-999,999
ADF5	User defined	Auxiliary pulse input total	0-999,999
BO2	None	Reset total for ADF2	OVERRIDE Binary Output, Object 2-ON
BO5	None	Reset total for ADF5	OVERRIDE Binary Output, Object 5-ON

### 2.2 BIDIRECTIONAL FLOW POINT INFORMATION

Point Type & Address	Engineering Units	Point Description	Range
AI2	Selectable (See volume/mass rate table)	Volume or mass rate	0-999,999
AI3	User defined	Generic analog input	0-999,999
AI4	User defined	Generic analog input	0-999,999
ADF2	Selectable (See volume/mass rate table)	Mode 1 volume or mass total	0-999,999
ADF4	Selectable (See volume/mass rate table)	Mode 2 volume or mass total	0-999,999
ADF5	User defined	Auxiliary pulse input total	0-999,999
BI1	None	Flow Direction Indication	0-Forward 1-Reverse
BO2	None	Reset total for ADF2	OVERRIDE Binary Output, Object 2-ON
BO4	None	Reset total for ADF4	OVERRIDE Binary Output, Object 2-ON
BO5	None	Reset total for ADF5	OVERRIDE Binary Output, Object 5-ON

## 2.3 VOLUME OR MASS RATE (AI2)

VOLUME OR MASS RATE		
D-100 LCD Display Engineering Units	D-100 Display Multiplier	Point File Engineering Units Description
L/S (L/Sec)	1	LPS
L/S	10	10LPS
L/M (L/Min)	1	LPM
L/M	10	10LPM
L/M	100	100LPM
L/M	1,000	KLPM
L/M	10,000	10KLPM
L/M	100,000	100KLM
L/M	1,000,000	MEGLPM
L/H (L/Hr)	1	LPH
L/H	10	10LPH
L/H	100	100LPH
L/H	1,000	KLPH
L/H	10,000	10KLPH
L/H	100,000	100KLH
L/H	1,000,000	MEGLPH
M <sup>3</sup> H (M <sup>3</sup> /Hr)	1	CMH
M <sup>3</sup> H	10	10CMH
M <sup>3</sup> H	100	100CMH
GPM (Gal/Min)	1	GPM
GPM	10	10GPM
GPH (Gal/Hr)	1	GPH
GPH	10	10GPH
GPH	100	100GPH
GPH	1,000	KGPH
GPH	10,000	10KGPH
GPH	100,000	100KGH
GPH	1,000,000	MEGGPH
MGD (Million Gallons/Day)	1	MGD
CFS (Ft <sup>3</sup> /Sec)	1	CFS
CFS	10	10CFS
CFS	100	100CFS
CFS	1,000	KCFS
CFS	10,000	10KCFS
CFS	100,000	100KCS
CFS	1,000,000	MEGCFS

CFM (Ft <sup>3</sup> /Min)	1	CFM
CFM	10	10CFM
CFM	100	100CFM
CFM	1,000	KCFM
CFM	10,000	10KCFM
CFM	100,000	100KCFM
CFM	1,000,000	MEGCFM
PPH (Lb/Hr)	1	PPH
PPH	10	10PPH
PPH	100	100PPH
PPH	1,000	KPPH
PPH	10,000	10KPPH
PPH	100,000	100KPPH
PPH	1,000,000	MEGPPH
KPH (Kg/Hr)	1	KPH
KPH	10	10KPH
KPH	100	100KPH
KPH	1,000	KKPH
KPH	10,000	10KKPH
KPH	100,000	100KKH
KPH	1,000,000	MEGKPH

#### 2.4 VOLUME OR MASS TOTAL (ADF2 & ADF4)

VOLUME OR MASS TOTAL		
D-100 LCD Display Engineering Units	D-100 Display Multiplier	Point File Engineering Units Description
GALLON	1	GAL
GALLON	10	10GAL
GALLON	100	100GAL
GALLON	1,000	KGAL
GALLON	10,000	10KGAL
GALLON	100,000	100KGL
GALLON	1,000,000	MEGGAL
LITER	1	LTR
LITER	10	10LTR
LITER	100	100LTR
LITER	1,000	KLTR
LITER	10,000	10KLTR
LITER	100,000	100KLR
LITER	1,000,000	MEGKLR

MTR^3 (M³)	1	M3
MTR^3	10	10M3
MTR^3	100	100M3
MTR^3	1,000	KM3
MTR^3	10,000	10KM3
MTR^3	100,000	100KM3
MTR^3	1,000,000	MEGKM3
FT^3 (Ft³)	1	FT3
FT^3	10	10FT3
FT^3	100	100FT3
FT^3	1,000	KFT3
FT^3	10,000	10KFT3
FT^3	100,000	100KF3
FT^3	1,000,000	MEGFT3
LBMASS (Lb Mass)	1	LB
LBMASS	10	10LB
LBMASS	100	100LB
LBMASS	1,000	KLB
LBMASS	10,000	10KLB
LBMASS	100,000	100KLB
LBMASS	1,000,000	MEGLB
KILOGM (Kilogram Mass)	1	KG
KILOGM	10	10KG
KILOGM	100	100KG
KILOGM	1,000	KKG
KILOGM	10,000	10KKG
KILOGM	100,000	100KKG
KILOGM	1,000,000	MEGKG

## 2.5 GENERIC ANALOG INPUT(S) (AI3 & AI4)

GENERIC ANALOG INPUT(S) AI3 & AI4		
Analog Device Engineering Units	Multiplier	Point File Engineering Units Description
Instantaneous Pressure		
PSI	1	PSI
BAR	1	BAR
KILOPASCAL	1	KPASC
Instantaneous Temperature		
DEG F	1	DEGF
DEG C	1	DEGC
Instantaneous Relative Humidity		
% RH	1	RH

Energy Rate		
KBTU/H	1	KBTUH
KW	1	KW
TONS	1	TONS
Volume Rate		
GPM (Gal/Min)	1	GPM
L/S (L/Sec)	1	LPS
M3H (M <sup>3</sup> /Hr)	1	M3H
CFS (Ft <sup>3</sup> /Sec)	1	CFS
CFM (Ft <sup>3</sup> /Min)	1	CFM
None (Not defined in N2)		
Any	Any	Any

## 2.6 SAMPLE .ddl FILES

### Sample Unidirectional Mode .ddl File

```

*****
* ONICON, D-100 Display: SERIAL NUMBER XXXXXX
* PROGRAM VERSION: DM2.022
* Metasys-N2 address: XXX
* Unidirectional Mode
*
* This DDL file is device specific to the above serial number
* This data is valid at time of creation (07/20/2005 05:27:42 PM) and can be rendered invalid due
* to field programming changes to engineering units or multipliers.
*****
@MODEL+
CSMODEL "ONICON", "VND"
*
AITITLE "Analog Inputs"
ADTITLE "Analog Data Points"
BOTITLE "Binary Outputs"
*
* ANALOG INPUTS COS AVAILABLE
CSAI "AI2",N,N,"VOLUMERT","GPM"
*
***** Unidirectional Mode Meters Only *****
* N2 READS ADF2 FOR VOLUME or MASS TOTALS.
* NOTE UNITS MULTIPLIER
CSAD "ADF2",N,N,"VOLUMTOT","10GAL"
*
*Reset Volume Totals with the command Override BO ON.
CSBO "BO2",Y,N,"RST_VOL","n/a","reset"
*
***** End Unidirectional Mode *****

```

Sample Bidirectional Mode .ddl File

\*\*\*\*\*

\* ONICON, D-100 Display: SERIAL NUMBER XXXXXX  
\* PROGRAM VERSION: DM2.022  
\* Metasys-N2 address: XXX  
\* Bidirectional Mode  
\*  
\* This DDL file is device specific to the above serial number  
\* This data is valid at time of creation (07/20/2005 05:27:42 PM) and can be rendered invalid due  
\* to field programming changes to engineering units or multipliers.  
\*

\*\*\*\*\*

@MODEL+

CSMODEL "ONICON", "VND"

\*

AITITLE "Analog Inputs"

BITITLE "Binary Inputs"

ADTITLE "Analog Data Points"

BOTITLE "Binary Outputs"

\*

\* ANALOG INPUTS COS AVAILABLE

CSAI "AI2",N,N,"VOLUMERT","GPM"

\*

\* BINARY INPUT COS AVAILABLE

CSBI "BI1",Y,Y,"MODEIND","N/A"

\*\*\*\*\* Unidirectional Mode Meters Only \*\*\*\*\*

\* N2 READS ADF2, ADF4 FOR VOLUME or MASS TOTALS.

\* NOTE UNITS MULTIPLIER

CSAD "ADF2",N,N,"M1VOLTOT","10GAL"

CSAD "ADF4",N,N,"M2VOLTOT","10GAL"

\*

\*Reset Volume Totals with the command Override BO ON.

CSBO "BO2",Y,N,"RST\_VOL","n/a","reset"

\*

\*\*\*\*\* End Bidirectional Mode \*\*\*\*\*

## **SECTION 3.0: NETWORK TROUBLESHOOTING TIPS**

### **3.1 TROUBLESHOOTING**

<b>Reported Problem</b>	<b>Possible Solutions</b>
Device will not communicate with the network controller.	<ul style="list-style-type: none"><li>• A unique address is required for each device on the network. Duplicate addresses will cause some or all of the devices on the network to quit working. (See section 1.6.1 of this manual for details.)</li><li>• The RS485 network cable connections are polarity sensitive and must be connected the same way on every device. (i.e. + to + and - to -). (See section 1.4.1 of this manual for details.)</li><li>• Shield drain connections should be daisy chained in the same manner as the signal cables for RS485. The shield drain wire should be left unterminated at the end of the cable and connected to earth only at the supervisory controller. Shield wires must not be connected to the RS485 connector on the D-100.</li><li>• The maximum number of devices allowed on a RS485 network segment without a repeater is 32. Adding more than 32 devices to a single segment may reduce the transceiver output voltage to a level that is too low to be distinguished from background noise on the cable.</li><li>• RS485 cable impedance should be matched to a termination resistor at the end of the cable. ONICON boards do not have a resistor for termination. A resistor should only be used if the display is the last device on the network cable. (See section 1.5.1 of this manual for details.)</li></ul>

<b>Reported Problem</b>	<b>Possible Solutions</b>
<p>Network communications are disrupted when the device is connected.</p>	<ul style="list-style-type: none"> <li>• The RS485 network cable connections are polarity sensitive and must be connected the same way on every device. (i.e. + to + and - to -). (See section 1.4.1 of this manual for details.)</li> <li>• A unique address is required for each device on the network. Duplicate addresses will cause some or all of the devices on the network to quit working. (See section 1.6.1 of this manual for details.)</li> <li>• Shield drain connections should be daisy chained in the same manner as the signal cables for RS485. The shield drain wire should be left unterminated at the end of the cable and connected to earth only at the network master controller. Shield wires must not be connected to the RS485 connector on the D-100.</li> </ul>

# D-100 PROCESSOR BOARD

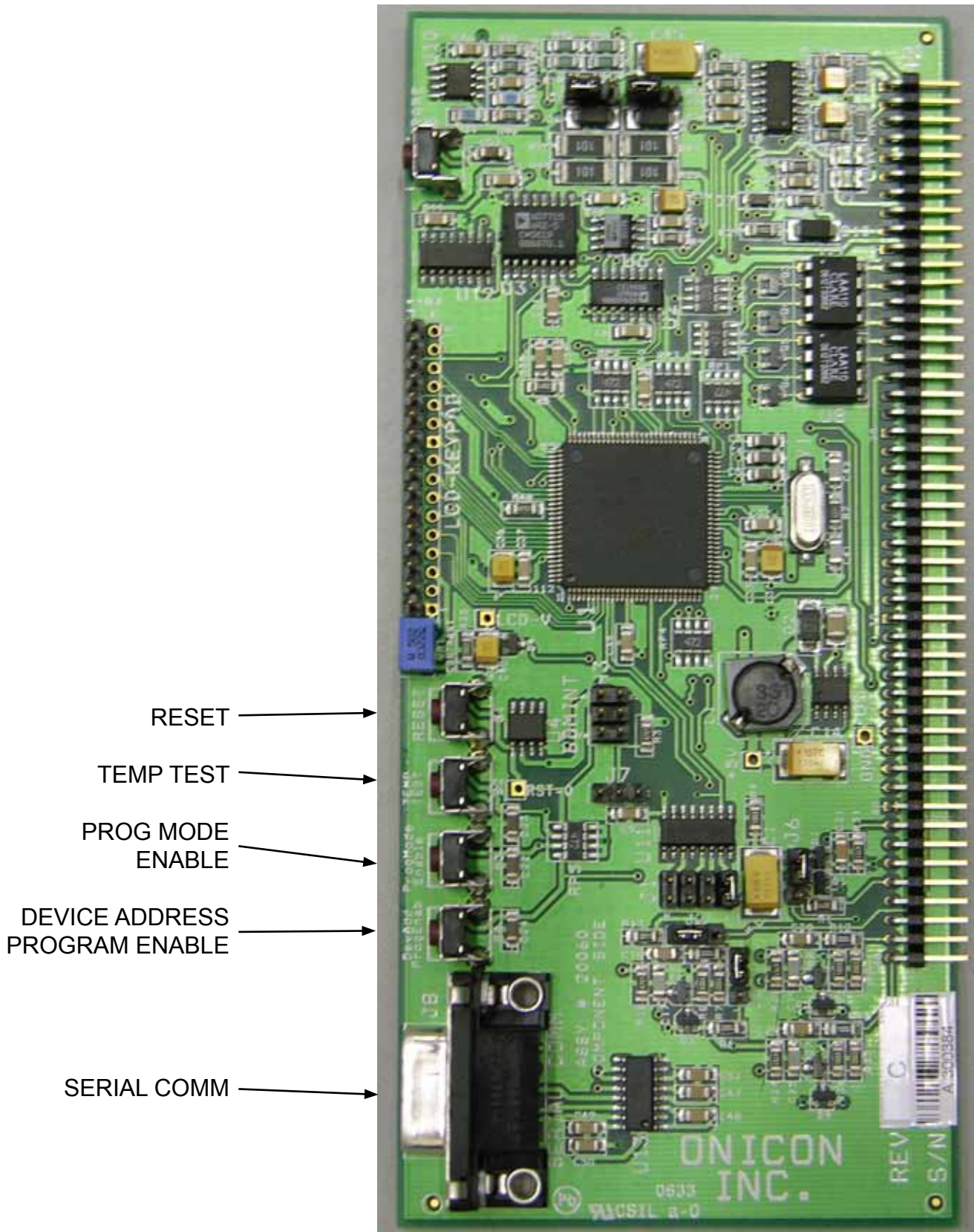

RESET

TEMP TEST

PROG MODE  
ENABLE

DEVICE ADDRESS  
PROGRAM ENABLE

SERIAL COMM