

**D-100 FLOW DISPLAY
MODBUS Network Interface Installation Guide**



TABLE OF CONTENTS

1.0	INTRODUCTION	5
1.1	PURPOSE OF THIS GUIDE	5
1.2	TYPICAL D-100 NETWORK INTERFACE MODULE	5
1.3	SPECIFICATIONS	5
1.4	NETWORK SIGNAL CONNECTIONS.....	6
1.4.1	RS485.....	6
1.4.2	TCP/IP	7
1.4.3	Optional Network Interface with Isolated Auxiliary Pulse Input	8
1.5	RS485 BAUD RATE, BIASING AND TERMINATION.....	11
1.5.1	Baud Rate	11
1.5.2	Biasing and Termination.....	12
1.6	NETWORK ADDRESSING.....	12
1.6.1	Changing the MAC (Device) Address.....	12
1.6.2	Changing the IP Address	14
1.6.3	Changing the Gateway Address.....	17
2.0	MODBUS MEMORY MAP.....	20
2.1	MODBUS REGISTER FORMAT AND NETWORKING INFORMATION	20
2.2	MODBUS MEMORY MAP TABLE	21
2.3	TOTALIZATION, RESETTING TOTALS, OVER-RANGE AND ROLLOVER	26
3.0	NETWORK TROUBLESHOOTING TIPS	28
3.1	TROUBLESHOOTING	28

APPENDIX

A-1	D-100 FLOW DISPLAY MODBUS TCP/IP BOARD
A-2	D-100 FLOW DISPLAY MODBUS RS485 BOARD
A-3	D-100 MODBUS TCP/IP AUXILIARY OUTPUT BOARD

SECTION 1: INTRODUCTION

1.1 PURPOSE OF THIS GUIDE

The purpose of this guide is to provide installation and commissioning procedures and basic operating and servicing instructions for the ONICON D-100 MODBUS RTU serial interface.

1.2 TYPICAL D-100 NETWORK INTERFACE MODULE

The D-100 is a totalizing display module that provides a local indication of liquid, gas or steam flow rate and total data. It can also be provided with an optional MODBUS RTU RS485 or MODBUS RTU TCP/IP serial interface to communicate data to the building control network.

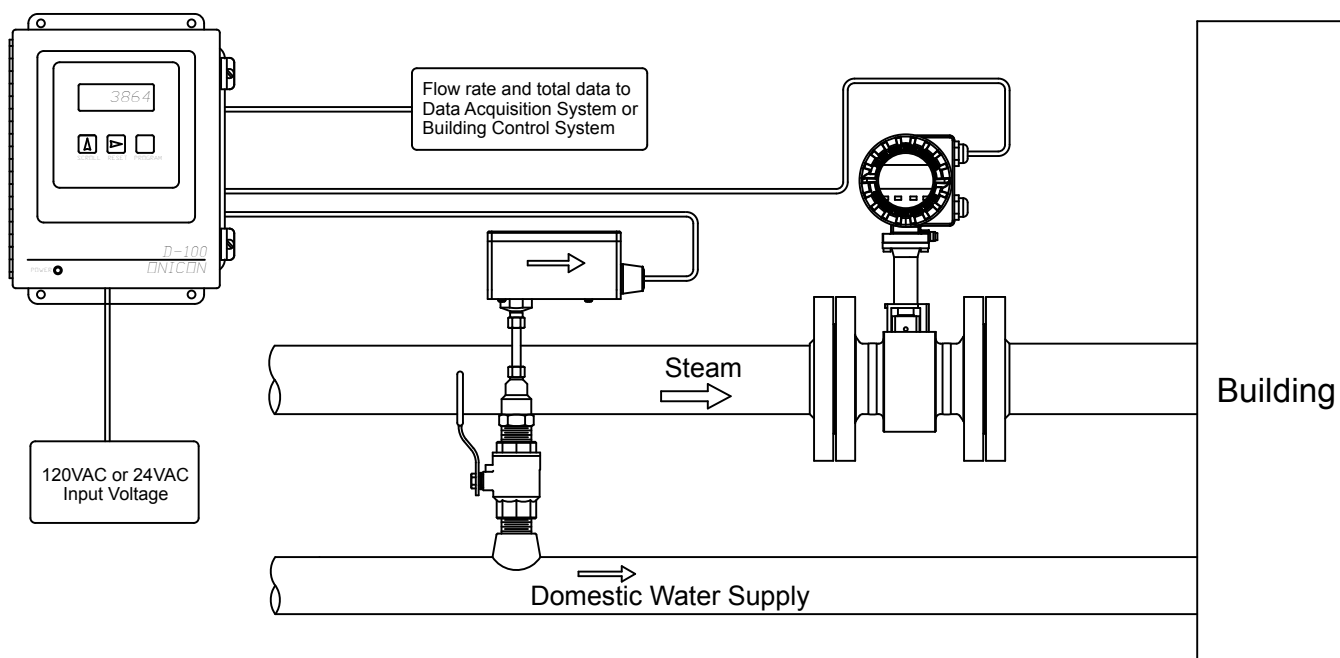

1.3 SPECIFICATIONS

MODBUS RTU NETWORK INTERFACE

RS485

Transceiver: 2-wire, half-duplex
Data format: 8 bit with 1 stop bit
Parity: None
MAC address (device address) range: 1 - 247 (Default: 017)
Baud rate: 1200, 2400, 4800, 9600, 19200, 38400, 57600 or 115200 (Default: 9600)
Termination: 120 ohms or none (Default: none)
Biasing: None
Flow control: None

TCP/IP

Transceiver: Base 10T, 10Mbps, Rj45 connection
Data format: 8 bit with 1 stop bit
Parity: None
MAC address (device address) range: 1 - 247 (Default: 017)
Default IP address: 192.168.1.24 (Port 502)
Flow control: None

1.4 NETWORK SIGNAL CONNECTIONS

1.4.1 RS485

MODBUS RS485, 2-wire (half-duplex) serial output connections are connected to terminal T1 as shown. Do not exceed 4.4 in-lb (0.5 Nm) of torque when tightening.



CAUTION

Only qualified service personnel should make connections between the D-100 Flow Display and the user's external equipment. ONICON assumes no responsibility for damage caused to the external equipment as a result of an improper installation.

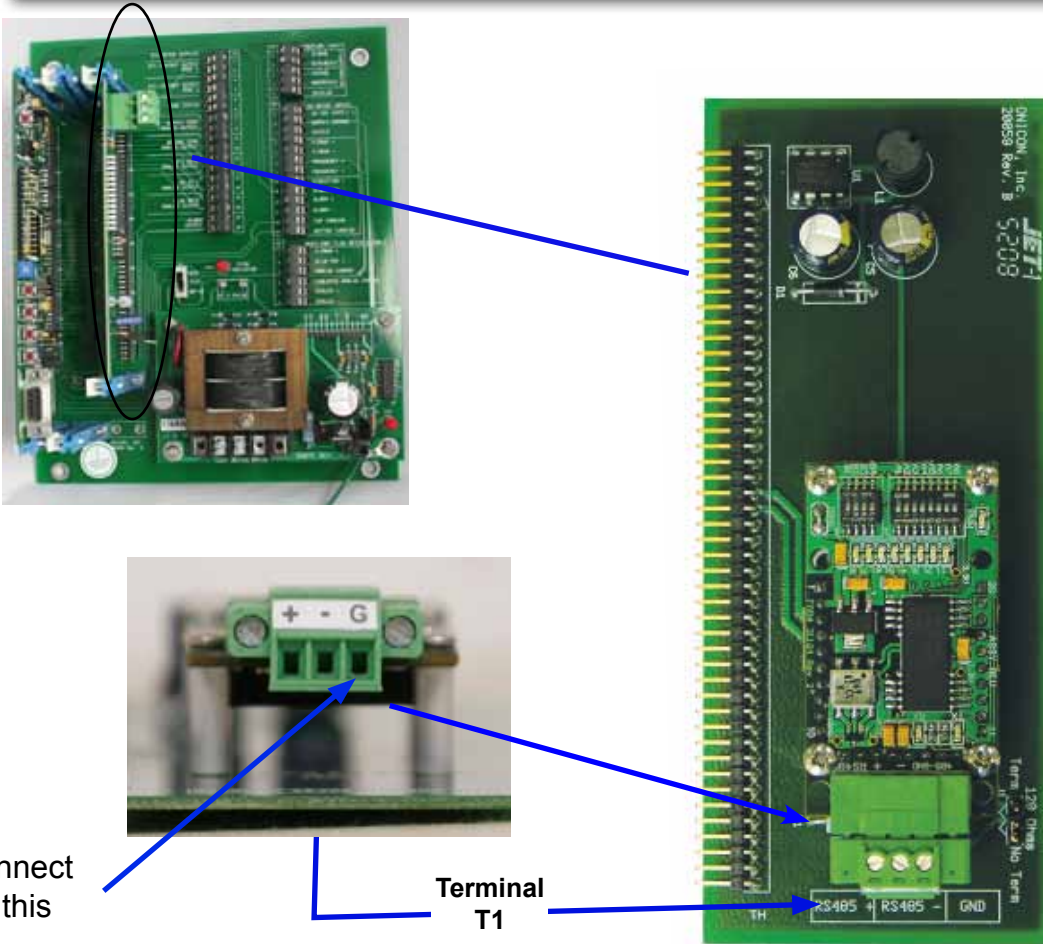

Do not connect shields to this terminal.

Terminal
T1



CAUTION

Incoming and outgoing RS485 cable shield wires should be connected together, but must not be connected to the display.

1.4.2 TCP/IP

MODBUS TCP, Base 10T output connections are made as shown. Requires Base 10T cable and RJ45 connector.



CAUTION

Only qualified service personnel should make connections between the D-100 Flow Display and the user's external equipment. ONICON assumes no responsibility for damage caused to the external equipment as a result of an improper installation.

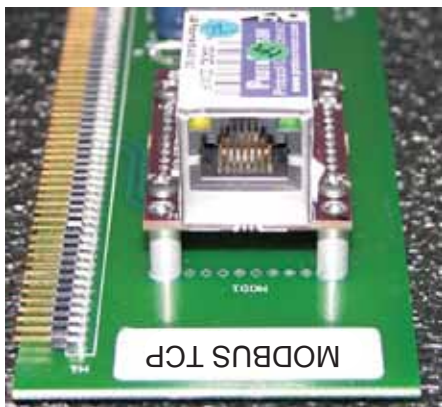
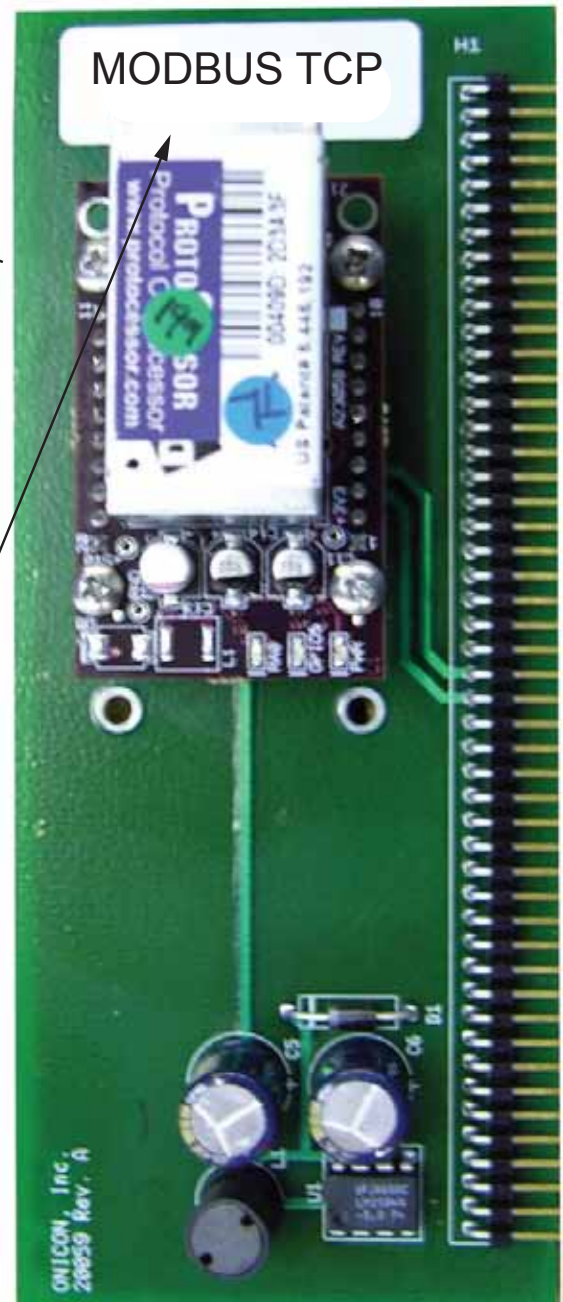

NOTE: RJ45 Connector

1.4.3 Optional Network Interface With Optional Isolated Auxiliary Pulse Input

The D-100-MODBUS Display can be provided with an auxiliary input pulse for totalizing pulse outputs from external devices such as water or gas meters. Pulses are accumulated in an internal register, and the totalized value is available on the network. This register can be zeroed via the network.

If the auxiliary pulse input option was ordered at the same time the display was ordered, it will arrive fully configured and ready to use. If it was ordered after the display was delivered and is being installed as a field upgrade, it may be necessary to configure the pulse input. The information is provided below and on the following pages:

The input pulse must meet the following criteria:

1. Frequency input range, 50 Hz maximum
2. 10 millisecond minimum pulse duration

Input Pulse Definition:

In order to configure the communications card for an auxiliary input pulse, you must first determine which type of pulse your meter produces. The allowable types of input pulses are described on the following pages. Based on the type of pulse, set the selector switch (S1) on the communications circuit board (Fig. 1) to the correct setting.

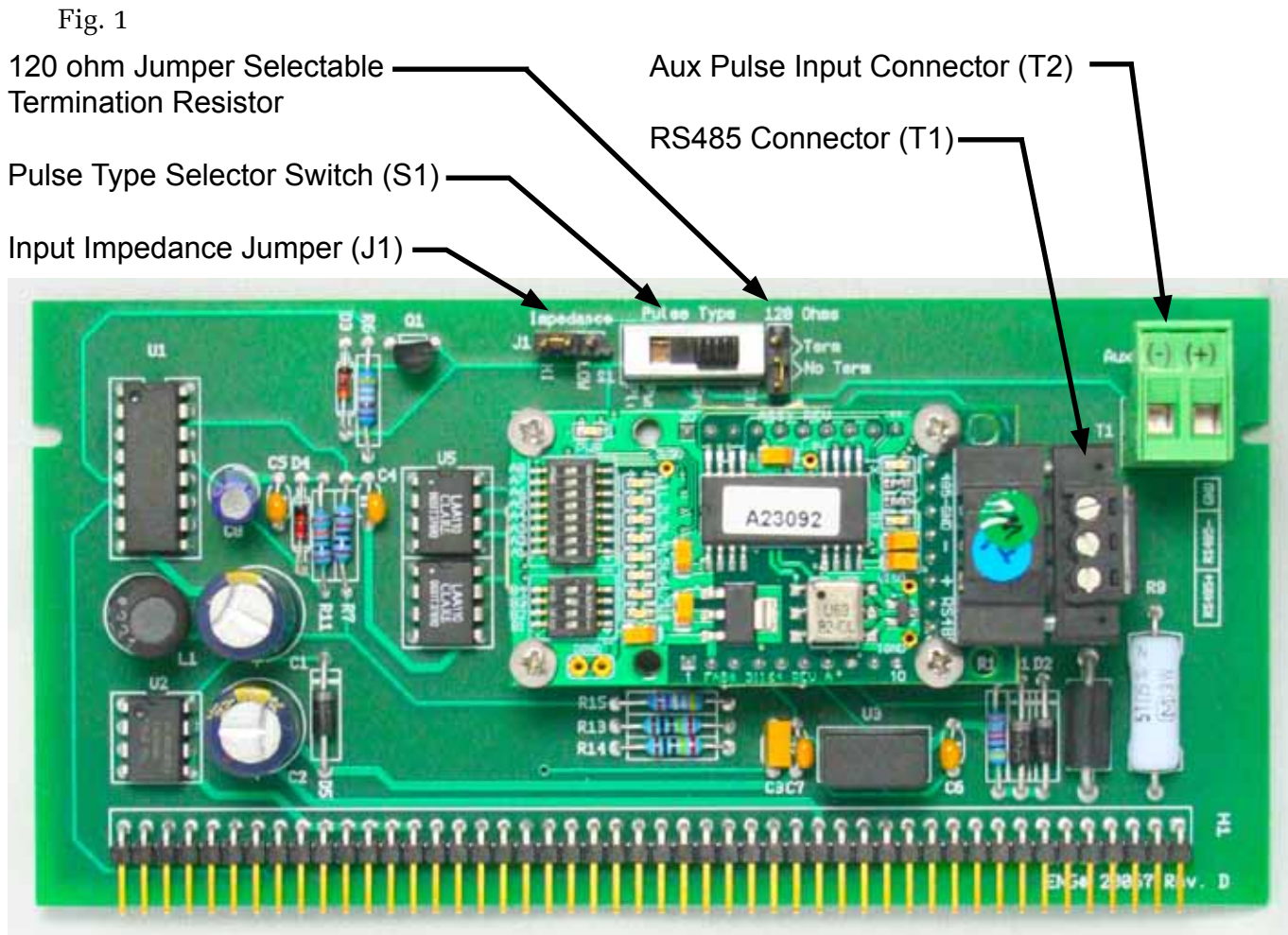

NOTE: MODBUS TCP shown above. See appendix A-3 for MODBUS TCP/IP auxiliary output board.

Powered Pulse:

This type of output refers to a pulse which has an associated voltage with it (see Fig. 2). Set the selector switch, S1 to PwrD Pulse. The allowable voltage range is 5-24 VDC. The input impedance is set at the factory to be 11 KOHM via the impedance selector jumper (J1, see Fig. 1). A lower impedance, 3 KOHM can be selected if required by the instrument providing the pulse output. Consult the instrument manufacturer or ONICON if you are uncertain as to the proper jumper selection.

Fig. 2

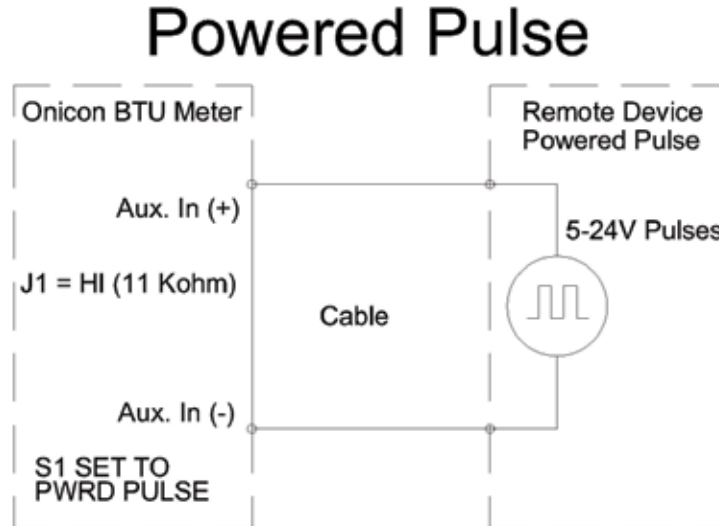

Open Collector (Sourcing):

This type of output refers to an open Collector Switch configured for a sourcing function (see Fig. 3). Set the selector switch, S1 to SRC. The switch must be rated for at least 20mA at 20VDC.

Fig. 3

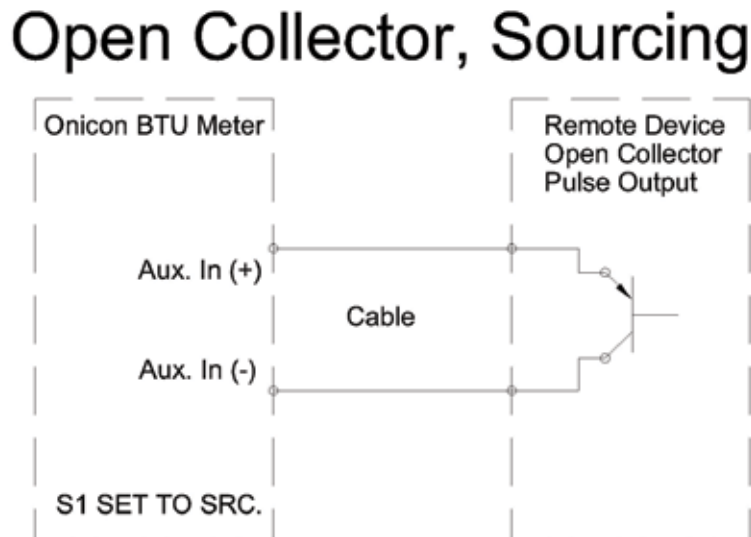

Open Collector Sinking or Dry Contact:

This type of output refers to an open collector switch configured in a current sinking arrangement or a dry contact switch (see Fig. 4 and 5). Set the selector switch, S1 to Sink. In either case, the switch must be rated for at least 20mA at 20 VDC.

Fig. 4

Open Collector, Sinking

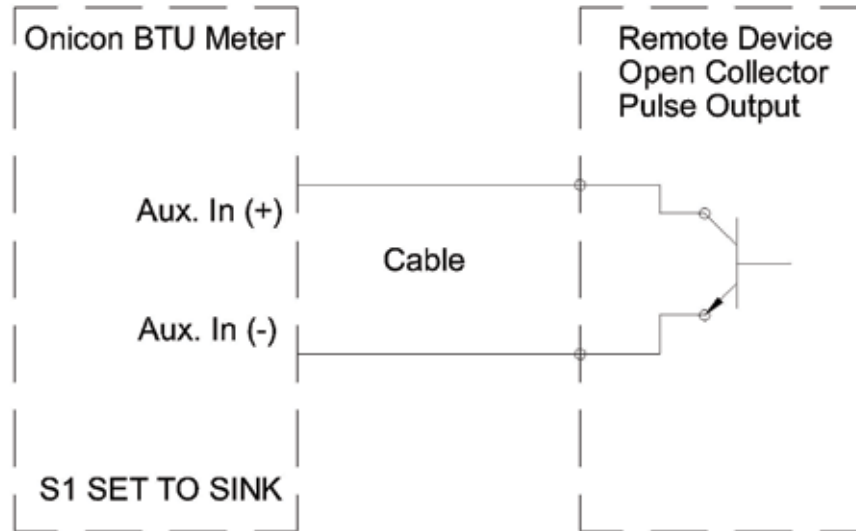
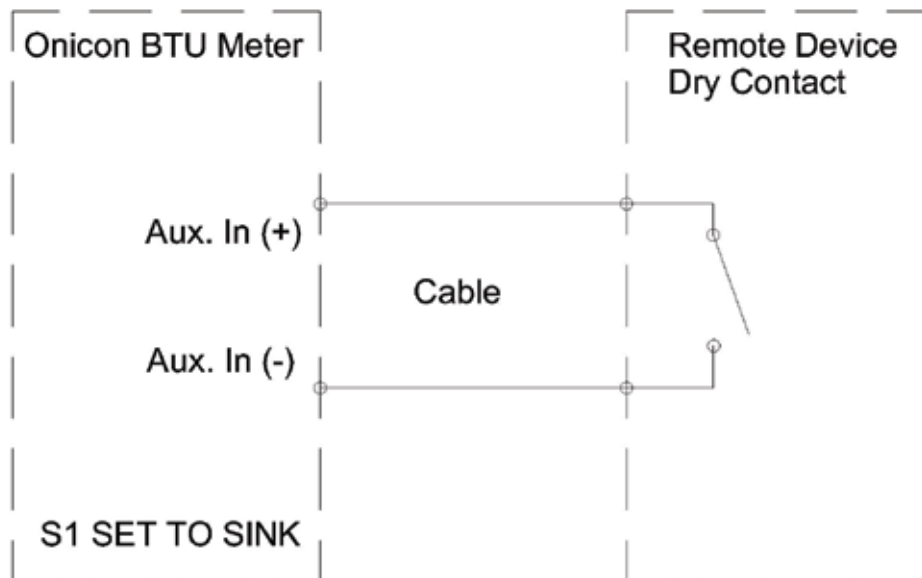

Fig. 5

Contact Closure



1.5 RS485 BAUD RATE, BIASING AND TERMINATION

1.5.1 Baud Rate

Every ONICON D-100 is individually programmed at the factory with application specific data provided by the customer during the process of ordering the display. This normally includes the Baud rate setting. If the Baud rate was provided, the display will be configured to operate at the specified rate. The available Baud rate settings are listed in the table below.

If the Baud rate setting was not provided to ONICON, the display will be configured to 9600.

The Baud rate setting can be manually changed in the field. The drawing and table below show the Baud rate dipswitch settings.

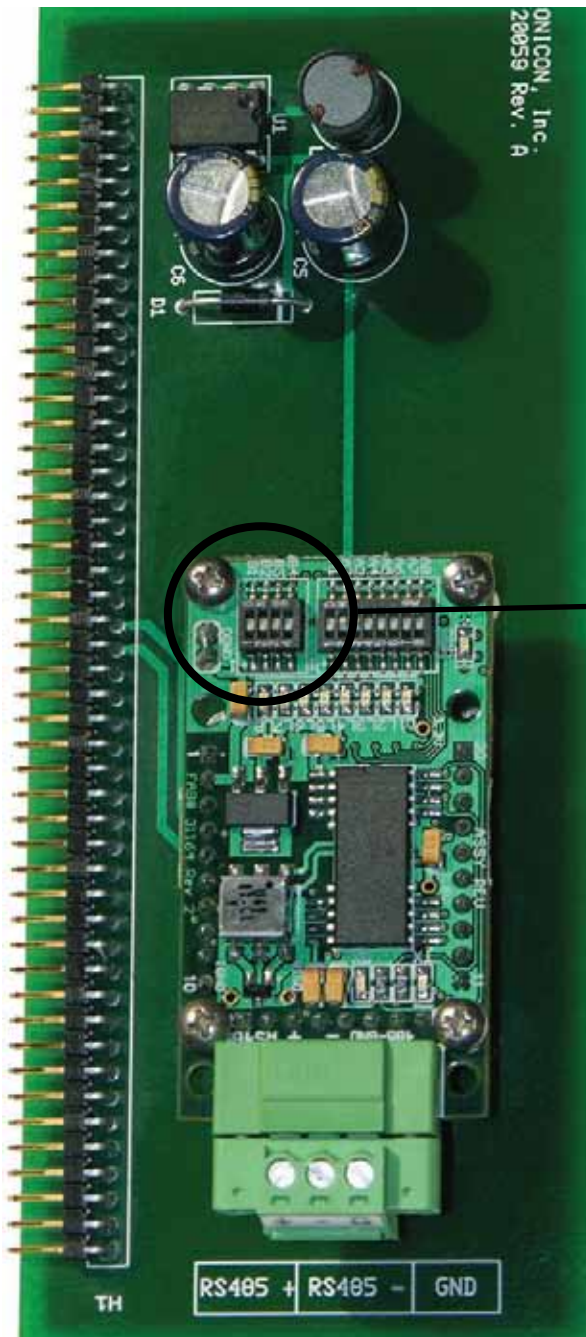

BAUD Rate	B1	B2	B3	B4
9600	OFF	OFF	OFF	OFF
1200	ON	OFF	OFF	OFF
2400	ON	ON	OFF	OFF
4800	ON	OFF	ON	OFF
9600	ON	ON	ON	OFF
19200	ON	OFF	OFF	ON
38400	ON	ON	OFF	ON
57600	ON	OFF	ON	ON
115200	ON	ON	ON	ON



Baud Rate Dip Switches

1.5.2 Biasing and Termination

The ONICON D-100 Flow Display does not provide biasing voltage to the RS485 network. A jumper selectable 120Ω resistor is provided as show below. The termination resistor should only be used when the meter is installed at the end of the line.

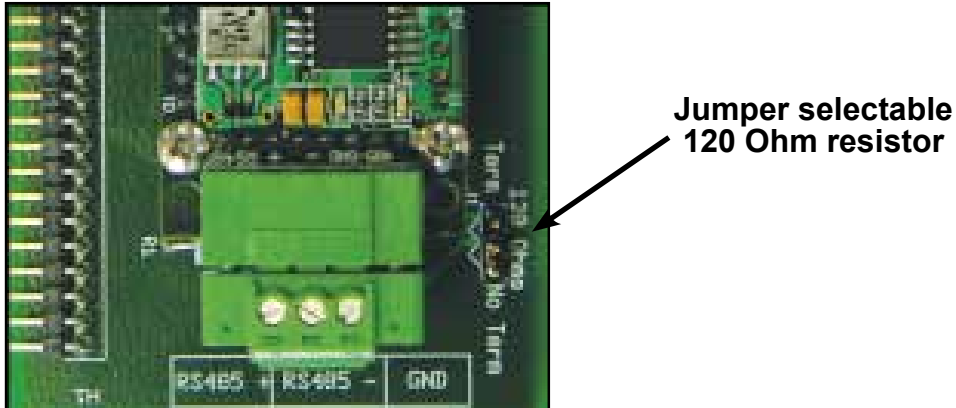

NOTE: See Fig. 1 on page 8 to locate the termination resistor on network interface board with auxiliary output.

1.6 NETWORK ADDRESSING

Before the D-100 can communicate on the MODBUS network, the appropriate device address must be programmed into the display. For TCP/IP networks an IP address must also be assigned to the display.

The MODBUS network address for ONICON D-100 displays may be set to any address from 001 to 247 in compliance with the MODBUS standard. This address is set at the display. Section 1.6.1 details the procedure for changing this address.

MODBUS TCP/IP displays also require an IP address to operate on the network. In addition, managed TCP/IP networks may require a gateway address. The procedures for entering the IP address and gateway address are detailed in sections 1.6.2 and 1.6.3. Both require the use of the RUInet utility program and a PC with an Ethernet card and an available port.

1.6.1 Changing the MAC (Device) Address

Every ONICON D-100 is individually programmed at the factory with application specific data provided by the customer during the ordering process, and this may include network addressing information. If the device address information was provided, the display will be programmed with that number. If no address is provided, ONICON displays are programmed with a default address of 017. The address may be changed at the D-100 using the procedure outlined in the table on the next page.

STEP	ACTION	REACTION	COMMENT
0	Obtain a device address from the network administrator.		The device address is a three digit number between 001-247, excluding zero.
1	With the display running, open the front panel and locate switch DEV ADD/PROG ENAB. Press DEV ADD/PROG ENAB and then release it.	None	The DEV ADD/PROG ENAB is located in the lower left corner of the processor board.
2	Close the front panel.		
3	Press the PROGRAM button. (If you do not press the PROGRAM button, the display will revert to the RUN mode after 5 minutes.)	The flow display changes to PROGRAM mode and the DEVICE ID page will appear with the first digit of the address flashing.	The PROGRAM button is on the front panel.
4	Successively press the SCROLL button to increment the number to the desired value from 0-9.	The number increments by one each time you press the button.	The SCROLL button is on the front panel.
5	Press the RESET button.	The second character blinks.	The RESET button is on the front panel.
6	Successively press the SCROLL button to increment the number to the desired value from 0-9.	The number increments by one each time you press the button.	The SCROLL button is on the front panel.
7	Press the RESET button.	The third character blinks.	The RESET button is on the front panel
8	Successively press the SCROLL button to increment the number to the desired value from 0-9.	The number increments by one each time you depress the button.	The SCROLL button is on the front panel.
9	Once the correct value has been entered, press PROGRAM.	The FRONT PANEL RESET page appears.	It is not necessary to change anything on this page.
10	Press the PROGRAM button.	The SAVE CHANGES page appears.	The new device address must be saved to take effect.
11	Press the SCROLL button.	The N changes to Y on the SAVE CHANGES page.	The Y must be selected in order for the new address to take effect.
12	Press the PROGRAM button.	The new address is saved and the display reverts to the RUN mode.	
13	Open the front panel and locate the RESET switch. Press to reset D-100.	When polled, the D-100 will automatically begin to communicate with the network.	RESET is located along the top of the processor board. (See appendix page A-2.)

1.6.2 Changing the IP Address

Changing the IP Address requires the use of RUInet utility software and a PC with an Ethernet card and an available port. Assuming the display is programmed with the default IP address (192.168.1.24), the host PC must be configured with an IP address of 192.168.1.1 and a subnet mask of 255.255.255.0. RUInet is supplied on a CD-ROM with a D-100-MOD Flow Display. It is also available for download from the ONICON website, www.onicon.com.

1. Load RUInet and configure the PC as necessary.
2. Connect and RJ45 Ethernet cable between the PC and the display and power the D-100. Allow 60 seconds for the display firmware to cycle through start-up diagnostic routines.
3. Open RUInet.
4. From the Remote User Interface main menu (shown on the next page) select option "I", Change IP Address.

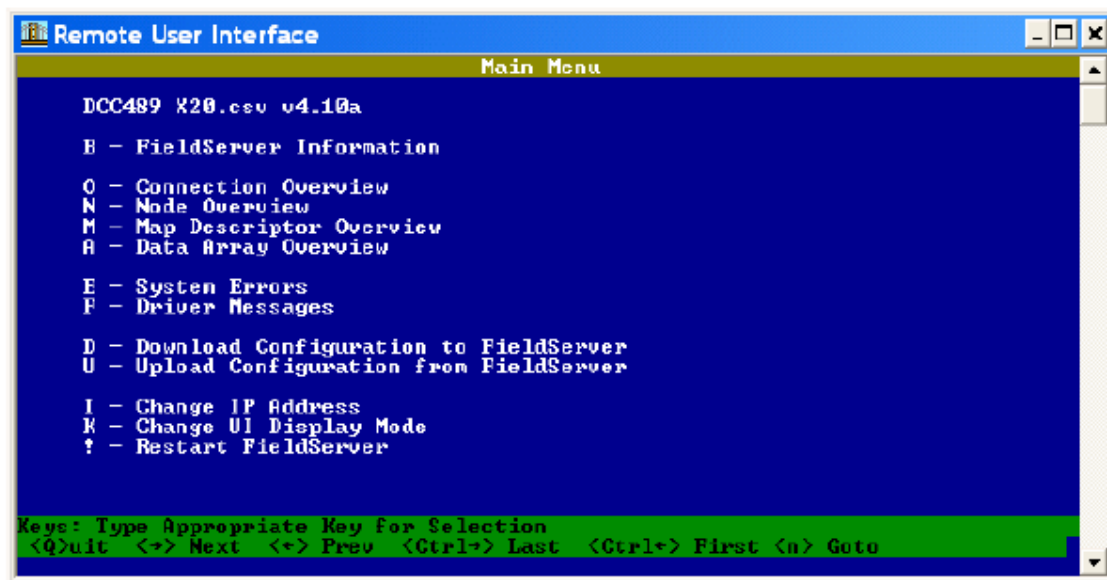

- From the Edit IP Address Settings menu (shown below) select option 1. Please note that the default subnet mask is 255.255.255.0 and should not be changed unless necessary.

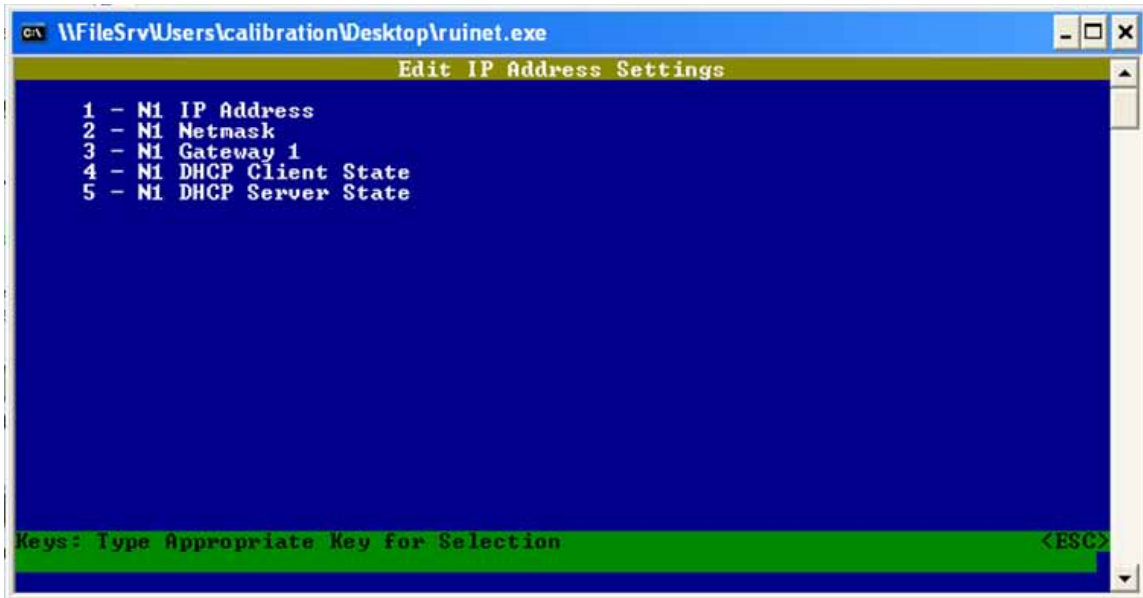

- Enter the new IP address as shown below and press enter.

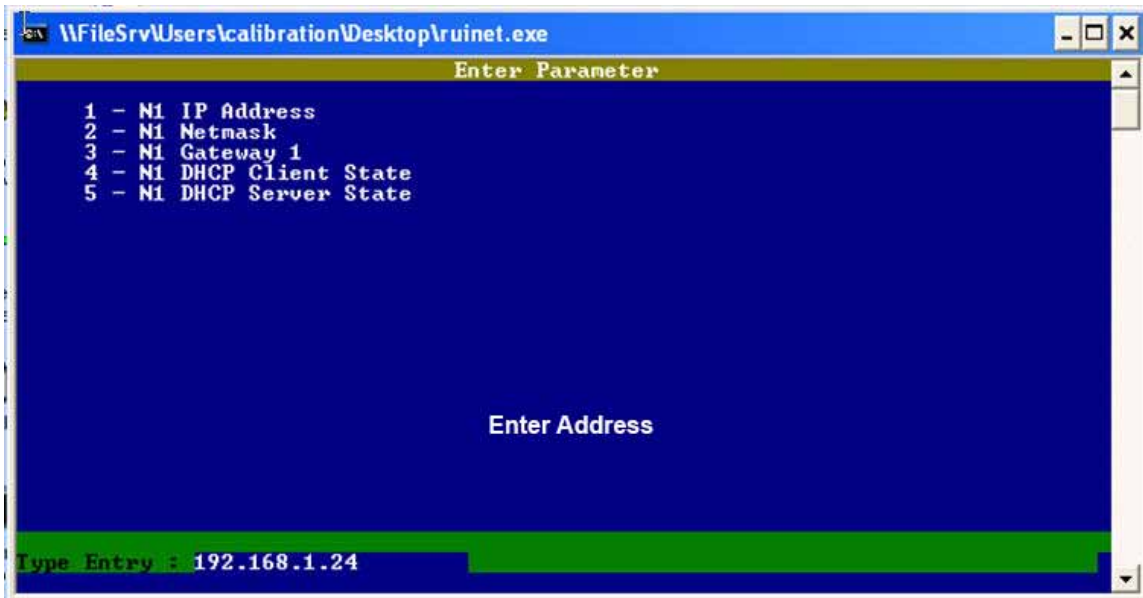

7. The following message will appear.

```
FileSrvUsers\calibration\Desktop\ruinet.exe
Enter Parameter

1 - N1 IP Address
2 - N1 Netmask
3 - N1 Gateway 1
4 - N1 DHCP Client State
5 - N1 DHCP Server State

Making changes, wait...

Type Entry : 192.168.1.24
```

8. When the address change is complete, the following message will appear. You must cycle power to the D-100 for the change to take effect.

```
FileSrvUsers\calibration\Desktop\ruinet.exe
Enter Parameter

1 - N1 IP Address
2 - N1 Netmask
3 - N1 Gateway 1
4 - N1 DHCP Client State
5 - N1 DHCP Server State

Changes only become active once
the FieldServer has been restarted.
Press any key to continue.

Type Entry : 192.168.1.24
```

1.6.3 Changing the Gateway Address

Changing the gateway address requires the use of RUInet utility software and a PC with an Ethernet card and an available port. Assuming the display is programmed with the default IP address (192.168.1.24), the host PC must be configured with an IP address of 192.168.1.1 and a subnet mask of 255.255.255.0. RUInet is available for download from the ONICON web site, www.onicon.com.

1. Load RUInet and configure the PC as necessary.
2. Connect an RJ45 Ethernet cable between the PC and the display and power the D-100. Allow 60 seconds for the display firmware to cycle through start-up diagnostic routines.
3. Open RUInet.
4. From the Remote User Interface main menu (shown below) select option "I", Change IP Address.

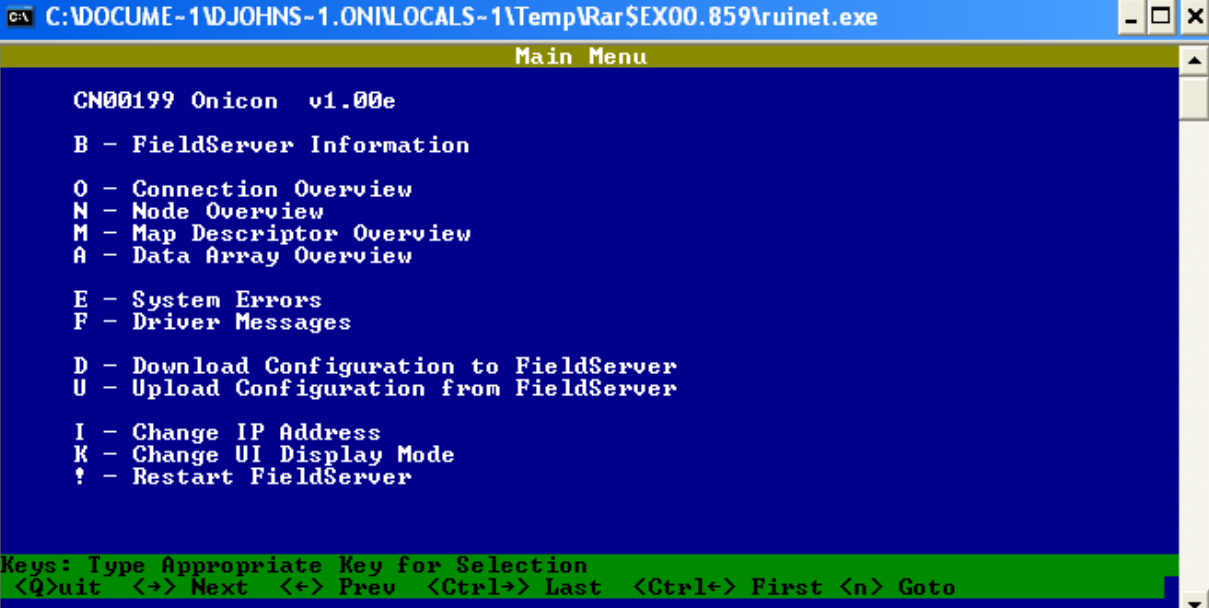

The screenshot shows a Windows application window titled "C:\DOCUME~1\DJOHNS-1\ONILOCALS~1\Temp\Rar\$EX00.859\ruinet.exe". The window content is a blue terminal-style interface with white text. At the top, it says "Main Menu". Below that, it displays "CN00199 Onicon v1.00e". A list of menu options follows: "B - FieldServer Information", "O - Connection Overview", "N - Node Overview", "M - Map Descriptor Overview", "A - Data Array Overview", "E - System Errors", "F - Driver Messages", "D - Download Configuration to FieldServer", "U - Upload Configuration from FieldServer", "I - Change IP Address", "K - Change UI Display Mode", and "? - Restart FieldServer". At the bottom, a green bar contains the text "Keys: Type Appropriate Key for Selection" followed by a list of keyboard shortcuts: "<Q>uit", "<=> Next", "<←> Prev", "<Ctrl+> Last", "<Ctrl+> First", and "<n> Goto".

```
C:\DOCUME~1\DJOHNS-1\ONILOCALS~1\Temp\Rar$EX00.859\ruinet.exe
Main Menu
CN00199 Onicon v1.00e
B - FieldServer Information
O - Connection Overview
N - Node Overview
M - Map Descriptor Overview
A - Data Array Overview
E - System Errors
F - Driver Messages
D - Download Configuration to FieldServer
U - Upload Configuration from FieldServer
I - Change IP Address
K - Change UI Display Mode
? - Restart FieldServer
Keys: Type Appropriate Key for Selection
<Q>uit <=> Next <←> Prev <Ctrl+> Last <Ctrl+> First <n> Goto
```

- From the Edit IP Address Settings menu (shown below) select option 3.

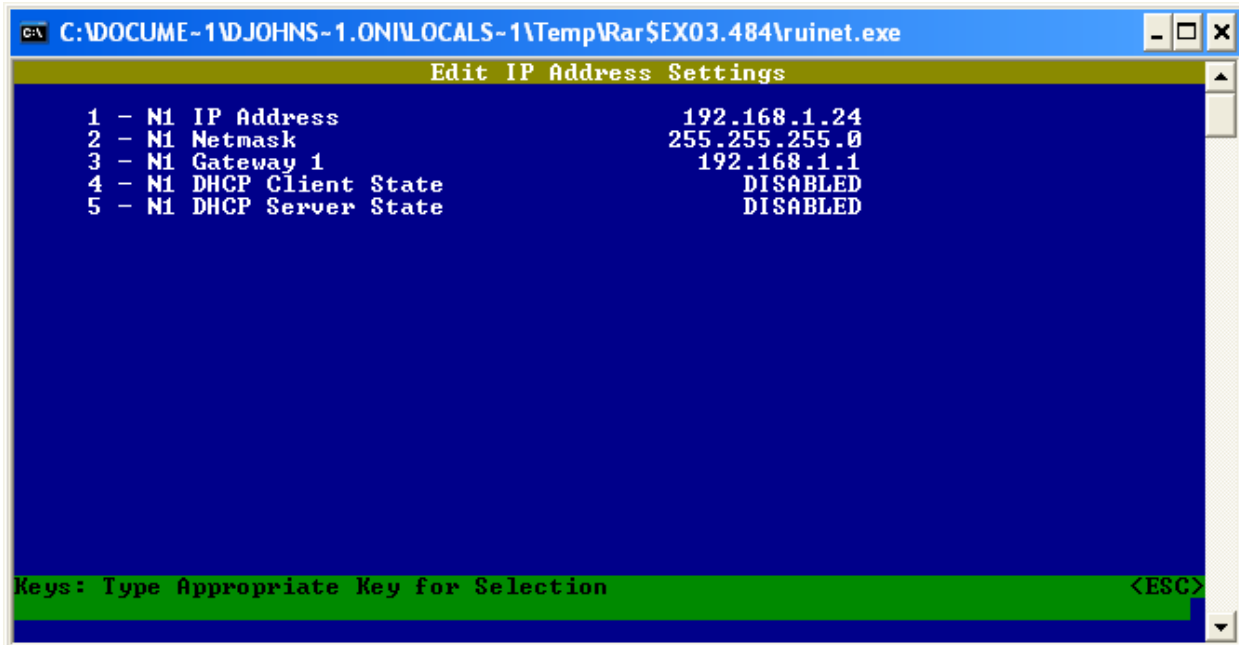

- Enter the new gateway address as shown below and press enter.

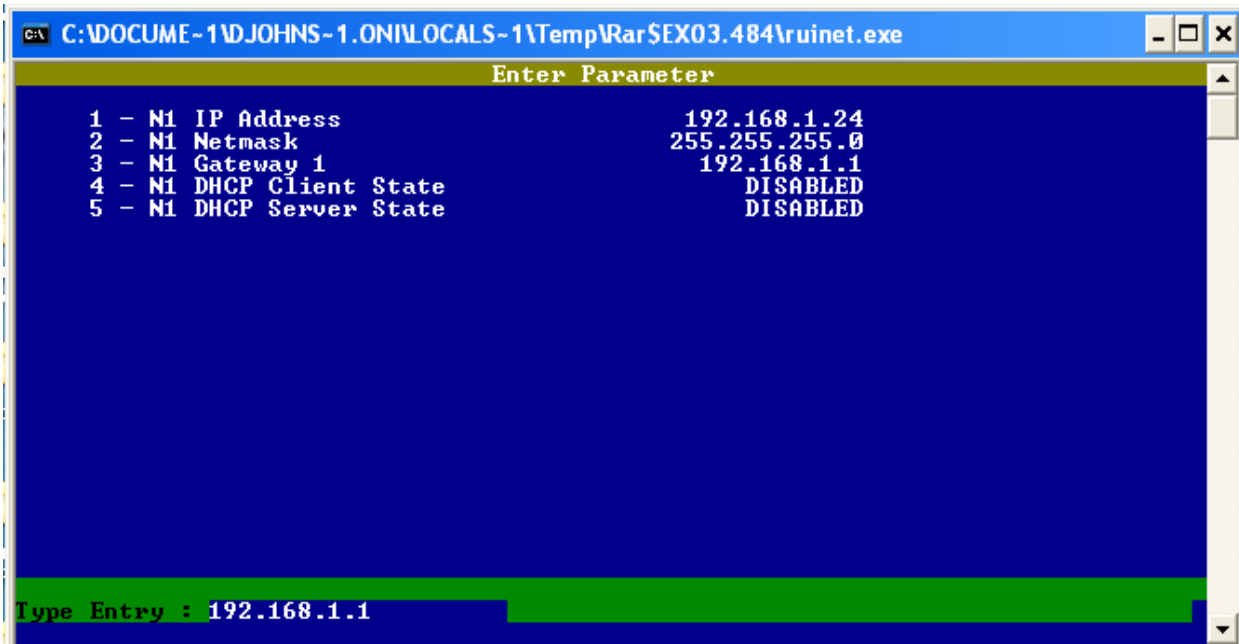

- The following message will appear.

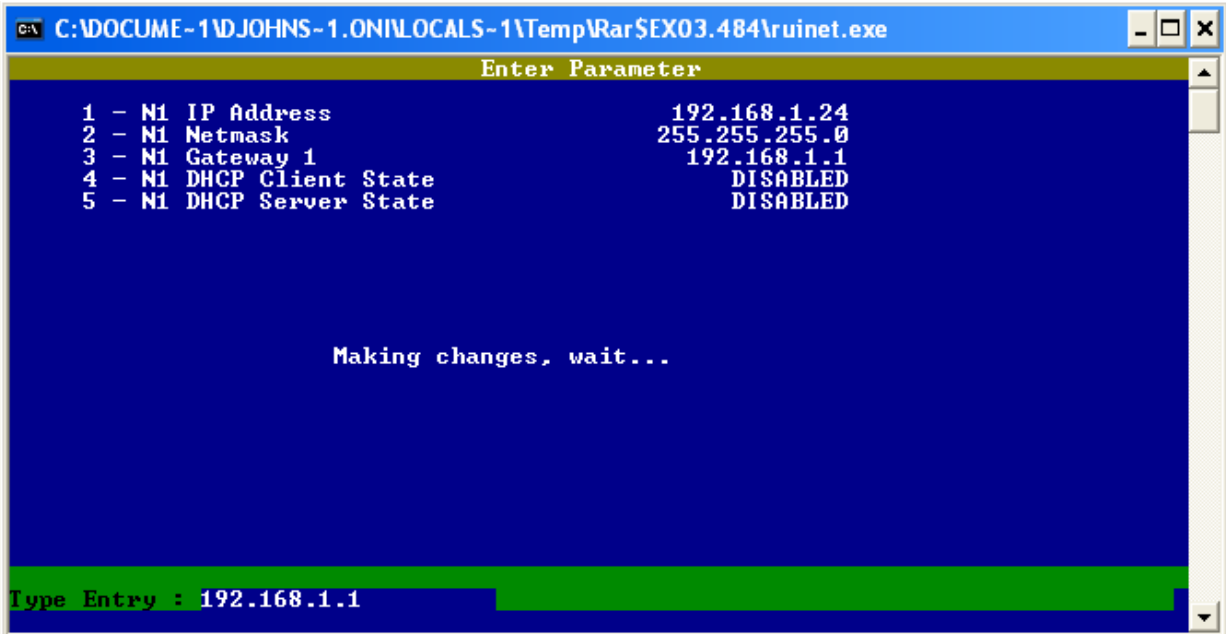

The screenshot shows a command window titled "C:\DOCUME-1\JOHNS-1\ONILLOCALS-1\Temp\Rar\$EX03.484\ruinet.exe". The window has a yellow title bar and a blue background. At the top, it says "Enter Parameter". Below that, there is a list of five parameters:

1 - N1 IP Address	192.168.1.24
2 - N1 Netmask	255.255.255.0
3 - N1 Gateway 1	192.168.1.1
4 - N1 DHCP Client State	DISABLED
5 - N1 DHCP Server State	DISABLED

Below the list, the text "Making changes, wait..." is displayed. At the bottom, there is a green input field with the text "Type Entry : 192.168.1.1".

- When the address change is complete, the following message will appear. You must cycle power to the D-100 for the change to take effect.

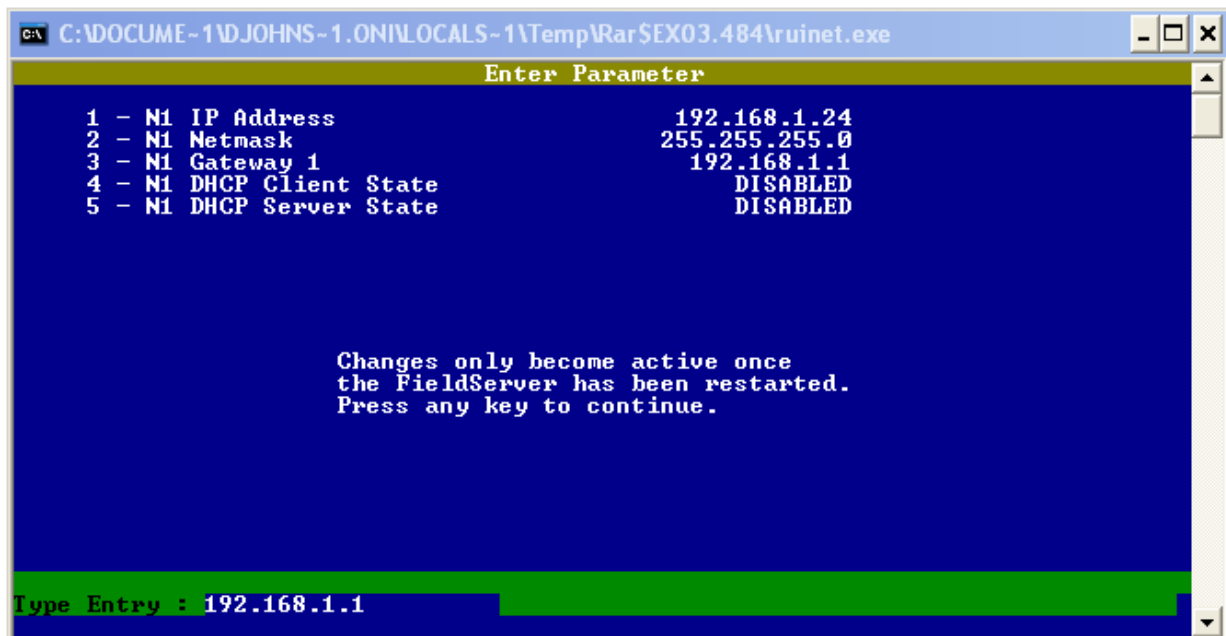

The screenshot shows the same command window as above. The text "Making changes, wait..." has been replaced by "Changes only become active once the FieldServer has been restarted. Press any key to continue." The green input field at the bottom still contains "Type Entry : 192.168.1.1".

SECTION 2.0: MODBUS MEMORY MAP

ONICON displays equipped with MODBUS serial communications provide volume rate data, and totalized volume data in a variety of engineering units. You select the engineering units you wish to use by mapping to the appropriate registers.

Also supplied with your D-100 is a document titled “Recommended MODBUS Configuration Data”. This document is different for each display. It provides a suggested list of registers to use. The recommendations are based on the calibration of the flow meter and the programming of units and multipliers displayed on the D-100.

2.1 MODBUS REGISTER FORMAT AND NETWORKING INFORMATION

1. All registers are 16 bit MODBUS Holding Registers.
2. MODBUS Holding Registers are used in 4 different ways.
 - A. As an Analog Value: In some cases these values are scaled by multiplying the register contents by a fixed multiplier.
 - B. As a status indicator where the register value can only be “1” or “2”.
 - C. As a mode indicator where the value indicates current operating mode such as “1” = single, “2” = dual, or “3” = bi-directional.
 - D. As a control register where the host can write a value to reset total(s).
3. Registers 40001 through 40068 are unsigned integer registers (0 to 65,535) except for 40024 and 40025. These are 16 bit signed integer values (-32,768 to +32,767). Registers 41003 through 41081 are 32 bit single precision floating point values. 41001, 41002 and 41065 through 41069 are unsigned integer registers.
4. D-100 MODBUS register addresses are formatted as follows:
Example: address **40001**
4 = Holding register
0001 = Address that corresponds to memory location 0000
5. MODBUS function codes supported:

CODE	DESCRIPTION
03	Read Holding Registers
06	Preset Single Registers
16	Preset Multiple Registers
17	Report Slave ID



IMPORTANT NOTE

ONICON provides data in integer and floating point format. We recommend the use of floating point registers to transmit data to the network. The use of floating point data eliminates the need for scaling and additional mathematical operations to totalize energy and flow.

Networking Information	MODBUS RTU	MODBUS TCP
Connection Information	RS485, 2-wire half-duplex	Base 10T, 10Mbps, RJ 45 Connection
Data format / Parity	8 bits, 1 stop bit / None	8 bits, 1 stop bit / None
Flow Control (handshaking)	None	None
Device Address Range	1 - 247	1 - 247
IP Address	Not required	Default address: 192.168.1.24
Termination (selectable)	120 Ω or none (default none)	None
Biasing	None	None

2.2 MODBUS MEMORY MAP TABLE

Available Engineering Units

Engineering Units	Abbreviation
Volume Rate (Flow)	
Gallons per minute	GPM
Gallons per minute x 10	GPM x 10
Gallons per hour	GPH
Million gallons per day	MGD
Liters per second	L/S
Liters per minute	L/M
Liters per hour	L/Hr
Cubic meters per hour	M ³ /Hr
Cubic meters per hour x 10	M ³ /Hr x 10
Cubic Feet per second	Ft ³ /S
Cubic Feet per minute	Ft ³ /M
Mass Rate (Mass Flow) – Only available with F-2000 Flow Meter	
Pounds per hour	Lb/Hr
Pounds per hour x 10	Lb/Hr x 10
Kilograms per hour	kg/Hr
Kilograms per hour x 10	kg/Hr x 10
Temperature	
Degrees Fahrenheit	°F
Degrees Celsius	°C
Generic	None

Engineering Units	Abbreviation
Volume Total	
Gallons x 1,000	kGal
Gallons x 1,000,000	MGal
Gallons x 1,000,000,000	GGal
Liters x 1,000	kLiters
Liters x 1,000,000	MLiters
Liters x 1,000,000,000	GLiters
Cubic Meters	M ³
Cubic Meters x 1,000	kM ³
Cubic Feet	Ft ³
Mass Total - Only available with F-2000 Flow Meter	
Pounds x 1,000	kLbs
Pounds x 1,000,000	MLbs
Kilograms x 1,000	Kkg
Kilograms x 1,000,000	Mkg

Register Address	Description	Register Range	Data Range	Over Range	Read/Write	Comment
41001	Meter Operating Mode Indicator		1 – 3	Not applicable	Read Only	1 – indicates single mode 2 – indicates dual mode 3 – indicates bi-directional mode
41002	Mode Status Indicator		1 – 2	Not applicable	Read Only	1 - indicates heating mode or forward direction 2 - indicates cooling mode or reverse direction

Register Address	Description	Register Type	Read/Write	Comment
41009	Volume Rate – GPM	Floating point register (1 of 2)	Read Only	
41010	Volume Rate – GPM	Floating point register (2 of 2)	Read Only	
41011	Volume Rate – GPH	Floating point register (1 of 2)	Read Only	
41012	Volume Rate – GPH	Floating point register (2 of 2)	Read Only	
41013	Volume Rate – MGD	Floating point register (1 of 2)	Read Only	
41014	Volume Rate – MGD	Floating point register (2 of 2)	Read Only	
41015	Volume Rate – L/S	Floating point register (1 of 2)	Read Only	
41016	Volume Rate – L/S	Floating point register (2 of 2)	Read Only	
41017	Volume Rate – L/M	Floating point register (1 of 2)	Read Only	
41018	Volume Rate – L/M	Floating point register (2 of 2)	Read Only	
41019	Volume Rate – L/Hr	Floating point register (1 of 2)	Read Only	
41020	Volume Rate – L/Hr	Floating point register (2 of 2)	Read Only	
41021	Volume Rate – M ³ /Hr	Floating point register (1 of 2)	Read Only	
41022	Volume Rate – M ³ /Hr	Floating point register (2 of 2)	Read Only	
41071	Volume Rate – Ft ³ /S	Floating point register (1 of 2)	Read Only	
41072	Volume Rate – Ft ³ /S	Floating point register (2 of 2)	Read Only	
41073	Volume Rate – Ft ³ /M	Floating point register (1 of 2)	Read Only	
41074	Volume Rate – Ft ³ /M	Floating point register (2 of 2)	Read Only	
41023	Mass Rate – Lb/Hr	Floating point register (1 of 2)	Read Only	Mass units are only available when using F-2000 Vortex Meter.
41024	Mass Rate – Lb/Hr	Floating point register (2 of 2)	Read Only	
41025	Mass Rate – Kg/Hr	Floating point register (1 of 2)	Read Only	
41026	Mass Rate – Kg/Hr	Floating point register (2 of 2)	Read Only	
41027	Supply Temperature – °F	Floating point register (1 of 2)	Read Only	
41028	Supply Temperature – °F	Floating point register (2 of 2)	Read Only	
41029	Return Temperature – °F	Floating point register (1 of 2)	Read Only	
41030	Return Temperature – °F	Floating point register (2 of 2)	Read Only	
41031	Supply Temperature – °C	Floating point register (1 of 2)	Read Only	
41032	Supply Temperature – °C	Floating point register (2 of 2)	Read Only	
41033	Return Temperature – °C	Floating point register (1 of 2)	Read Only	
41034	Return Temperature – °C	Floating point register (2 of 2)	Read Only	
41075	Generic Rate Ai3	Floating point register (1 of 2)	Read Only	There are no engineering units associated with these registers.
41076	Generic Rate Ai3	Floating point register (2 of 2)	Read Only	
41077	Generic Rate Ai4	Floating point register (1 of 2)	Read Only	
41078	Generic Rate Ai4	Floating point register (2 of 2)	Read Only	

Register Address	Description	Register Type			Read/Write	Comment
41047	Volume Total Mode 1 –Gal	Floating point register (1 of 2)			Read Only	
41048	Volume Total Mode 1 –Gal	Floating point register (2 of 2)			Read Only	
41049	Volume Total Mode 2 –Gal	Floating point register (1 of 2)			Read Only	
41050	Volume Total Mode 2 –Gal	Floating point register (2 of 2)			Read Only	
41051	Volume Total Mode 1 – Liters	Floating point register (1 of 2)			Read Only	
41052	Volume Total Mode 1 – Liters	Floating point register (2 of 2)			Read Only	
41053	Volume Total Mode 2 – Liters	Floating point register (1 of 2)			Read Only	
41054	Volume Total Mode 2 – Liters	Floating point register (2 of 2)			Read Only	
41055	Volume Total Mode 1 – M ³	Floating point register (1 of 2)			Read Only	
41056	Volume Total Mode 1 – M ³	Floating point register (2 of 2)			Read Only	
41057	Volume Total Mode 2 – M ³	Floating point register (1 of 2)			Read Only	
41058	Volume Total Mode 2 – M ³	Floating point register (2 of 2)			Read Only	
41079	Volume Total Mode 1 – Ft ³	Floating point register (1 of 2)			Read Only	
41080	Volume Total Mode 1 – Ft ³	Floating point register (2 of 2)			Read Only	
41081	Volume Total Mode 2 – Ft ³	Floating point register (1 of 2)			Read Only	
41082	Volume Total Mode 2 – Ft ³	Floating point register (2 of 2)			Read Only	
41059	Mass Total –Lbs	Floating point register (1 of 2)			Read Only	Mass units are only available when using F-2000 Vortex Meter.
41060	Mass Total –Lbs	Floating point register (2 of 2)			Read Only	
41061	Mass Total –kg	Floating point register (1 of 2)			Read Only	
41062	Mass Total –kg	Floating point register (2 of 2)			Read Only	
41063	Auxiliary Input Total	Floating point register (1 of 2)			Read Only	
41064	Auxiliary Input Total	Floating point register (2 of 2)			Read Only	
41066	Zero Mode 1 Volume Total	0 – 1	0 – 1	Not applicable	Read/Write	Write a value of 1 to registers to reset totals. Re-write a value of zero to the register once the totals reset.
41068	Zero Mode 2 Volume Total	0 – 1	0 – 1	Not applicable	Read/Write	
41069	Zero Auxiliary Input Total	0 – 1	0 – 1	Not applicable	Read/Write	
41070	Reserved for future use					

REGISTER ADDRESS	DESCRIPTION	REGISTER RANGE	DATA RANGE	OVER RANGE	READ/ WRITE	COMMENT
40001	Meter Operating Mode Indicator		1 – 3	Not applicable	Read Only	1 – indicates single mode 2 – indicates dual mode 3 – indicates bi-directional mode
40002	Mode Status Indicator		1 – 2	Not applicable	Read Only	1 - indicates heating mode or forward direction 2 - indicates cooling mode or reverse direction
40009	Volume Rate – GPM	0 – 65535	0 – 65534	65535	Read Only	
40010	Volume Rate – GPM x 10	0 – 65535	0 – 65534	65535	Read Only	
40011	Volume Rate – GPH	0 – 65535	0 – 65534	65535	Read Only	
40012	Volume Rate – MGD	0 – 65535	0 – 65534	65535	Read Only	
40013	Volume Rate – L/S	0 – 65535	0 – 65534	65535	Read Only	
40014	Volume Rate – L/M	0 – 65535	0 – 65534	65535	Read Only	
40015	Volume Rate – L/Hr	0 – 65535	0 – 65534	65535	Read Only	
40016	Volume Rate – M ³ /Hr	0 – 65535	0 – 65534	65535	Read Only	
40017	Volume Rate – M ³ /Hr x 10	0 – 65535	0 – 65534	65535	Read Only	
40018	Mass Rate – Lb/Hr	0 – 65535	0 – 65534	65535	Read Only	Mass units are only available when using F-2200 Vortex Meter.
40019	Mass Rate – Lb/Hr x 10	0 – 65535	0 – 65534	65535	Read Only	
40020	Mass Rate – kg/Hr	0 – 65535	0 – 65534	65535	Read Only	
40021	Mass Rate – kg/Hr x 10	0 – 65535	0 – 65534	65535	Read Only	
40022	Supply Temperature – °F	0 – 65535	0 - 655.35	Not applicable	Read Only	Multiply by 0.01 to read temperature to 2 decimal places.
40023	Return Temperature – °F	0 – 65535	0 - 655.35	Not applicable	Read Only	
40024	Supply Temperature – °C	-32768 to +32767	-327.68 to +327.67	Not applicable	Read Only	
40025	Return Temperature – °C	-32768 to +32767	-327.68 to +327.67	Not applicable	Read Only	

Register Address	Description	Register Range	Data Range	Over Range	Read/Write	Comment
40042	Volume Total Mode 1 - kGal	0 – 65535	0 – 999		Read Only	Low Order
40043	Volume Total Mode 1 - MGal	0 – 65535	0 – 999		Read Only	Middle Order
40044	Volume Total Mode 1 – GGal	0 – 65535	0 – 65534	65535	Read Only	High Order
40045	Volume Total Mode 2 – kGal	0 – 65535	0 – 999		Read Only	Low Order
40046	Volume Total Mode 2 – MGal	0 – 65535	0 – 999		Read Only	Middle Order
40047	Volume Total Mode 2 – GGal	0 – 65535	0 – 65534	65535	Read Only	High Order
40048	Volume Total Mode 1 – kLiters	0 – 65535	0 – 999		Read Only	Low Order
40049	Volume Total Mode 1 – MLiters	0 – 65535	0 – 999		Read Only	Middle Order
40050	Volume Total Mode 1 – GLiters	0 – 65535	0 – 65534	65535	Read Only	High Order
40051	Volume Total Mode 2 – kLiters	0 – 65535	0 – 999		Read Only	Low Order
40052	Volume Total Mode 2 – MLiters	0 – 65535	0 – 999		Read Only	Middle Order
40053	Volume Total Mode 2 – GLiters	0 – 65535	0 – 65534	65535	Read Only	High Order
40054	Volume Total Mode 1 – M ³	0 – 65535	0 – 999		Read Only	Low Order
40055	Volume Total Mode 1 – KM ³	0 – 65535	0 – 65534	65535	Read Only	High Order
40056	Volume Total Mode 2 – M ³	0 – 65535	0 – 999		Read Only	Low Order
40057	Volume Total Mode 2 – KM ³	0 – 65535	0 – 65534	65535	Read Only	High Order
40058	Mass Total – kLbs	0 – 65535	0 – 999		Read Only	Mass units are only available when using F-2200 Vortex Meter.
40059	Mass Total – MLbs	0 – 65535	0 – 65534	65535	Read Only	
40060	Mass Total – Kkgs	0 – 65535	0 – 999		Read Only	
40061	Mass Total – Mkgs	0 – 65535	0 – 65534	65535	Read Only	
40062	Auxiliary Input Total	0 – 65535	0 – 999		Read Only	Low Order
40063	Auxiliary Input Total (x1000)	0 – 65535	0 – 65534	65535	Read Only	High Order
40065	Zero Mode 1 Volume Total	0 – 1	0 – 1	Not applicable	Read/Write	Write a value of 1 to registers to reset totals. Re-write a value of zero to registers once the totals reset.
40067	Zero Mode 2 Volume Total	0 – 1	0 – 1	Not applicable	Read/Write	
40068	Zero Auxiliary Input Total	0 – 1	0 – 1	Not applicable	Read/Write	

2.3 TOTALIZATION, RESETTING TOTALS, OVER-RANGE & ROLLOVER

1. Integer Register Totalization

Holding registers 40026 through 40061 are integer registers that provide totalized, volume and mass flow data in a variety of engineering units. The registers are organized into pairs or groups of 3.

The first (low order) register is limited to a range of 0 – 999. This register rolls over to zero when the total value reaches 1,000. If the registers are in a group of 3, the second register (middle order) is also limited to a range of 0 – 999. This register also rolls over when the register value reaches 1,000.

The second, or in the case of groups of 3, third, (high order) register is scaled such that the smallest incremental value indicated is 1,000 times greater than the preceding register. An example of this is shown below.

Example - A group of 3 registers

<u>Register</u>	<u>Engineering Units & Scaling</u>	<u>Current Value</u>
40042	kGal (Gallons x 1,000)	00500
40043	MGal (Gallons x 1,000,000)	00015
40044	GGal (Gallons x 1,000,000,000)	00111

Low order + middle order + high order = Gallons Total = 111,015,500,000
or
kGal Total = 111,015,500

Registers 40062 and 40063 provide totalization for the optional auxiliary pulse input option of the D-100. There are no engineering units associated with these registers.

2. Floating Point Register Totalization

Registers 41003 through 41082 (except 41065 - 41069) provide energy, volume and mass flow data in 32 bit single precision floating point format. The registers are organized into pairs. Each pair must be concatenated according to IEEE 754.

Word order: Most significant value first, least significant value second.
Byte order within each word: Most significant byte first.
Bit order within each byte: Most significant bit first.

Registers 41063 and 41064 provide totalization for the optional auxiliary pulse input option of the D-100. There are no engineering units associated with these registers.

3. Resetting Totals

Registers 40064 through 40068 or 41065 through 41069 are integer registers that provide a mechanism to reset totals. Each reset register is associated with a group of totalizing registers and will reset all of the engineering units at the same time. Both integer and floating point registers will be reset at the same time regardless of which set of reset registers are used.

To reset the totals associated with the register write a value of 1 to the register. Once the totals are reset, re-write a value of 0 to the register.



IMPORTANT NOTE

The D-100 contains internal registers for totalization. These registers will also be reset by this action.

4. Over-range & Rollover Conditions for Totals

All low order and middle order integer registers are designed to rollover to 0 when their totals exceed 999. The maximum value that can be totalized in high order integer registers is 65,534. A value of 65,535 is considered an over-range condition.



CAUTION

The D-100 contains internal registers for totalization. These registers will eventually roll over to zero if the totals are not reset on a periodic basis. The associated MODBUS registers will also roll over to zero when this occurs. The engineering units and multipliers programmed in to the D-100 affect the point at which the totals roll over. The factory assigned engineering units and multipliers applied to the D-100 were chosen to eliminate the possibility of an over-range condition in the MODBUS integer registers before the display registers roll over. Changing the engineering units or multipliers at the display will affect the rollover point. Contact ONICON for technical service prior to making any changes.

SECTION 3.0: NETWORK TROUBLESHOOTING TIPS

3.1 TROUBLESHOOTING

Reported Problem	Possible Solutions
Device will not communicate with the network controller.	<ul style="list-style-type: none">• Is the receive LED flashing on the network board? This LED will flash whenever there is traffic on the network. If the LED is not flashing, look for an open network cable.• Is the transmit LED flashing? The transmit LED will only flash when the device is responding to a poll. A unique address is required for each device on the network. Duplicate addresses will cause some or all of the devices on the network to quit working. (See section 1.6.1 of this manual for details.)• The RS485 network cable connections are polarity sensitive and must be connected the same way on every device (i.e. + to + and - to -). (See section 1.4.1 of this manual for details.)• The Baud rate setting must match the network Baud rate. (See section 1.5.1 of this manual for details.)• Shield drain connections should be daisy chained in the same manner as the signal cables for RS485. The shield drain wire should be left unterminated at the end of the cable and connected to earth only at the network master controller. Shield wires must not be connected to the RS485 connector on the D-100.• The maximum number of devices allowed on a RS485 network segment without a repeater is 32. Adding more than 32 devices to a single segment may reduce the transceiver output voltage to a level that is too low to be distinguished from background noise on the cable.

Reported Problem	Possible Solutions
<p>Device will not communicate with the network controller (cont.)</p>	<ul style="list-style-type: none"> • RS485 cable impedance should be matched to a termination resistor at the end of the cable. ONICON boards have a jumper selectable 120 ohm resistor for termination. This resistor should only be used if the display is the last device on the network cable. (See section 1.5.2 of this manual for details.) • A unique IP address is required for each device on TCP/IP networks. Duplicate addresses will cause multiple devices to respond to the same poll. This will cause some or all of the devices on the network to quit working. (See section 1.6.2 of this manual for details.) • Managed TCP/IP networks may require that a gateway IP address be programmed into the ONICON TCP/IP device. (See section 1.6.3 of this manual for details.)
<p>Network communications are disrupted when the device is connected.</p>	<ul style="list-style-type: none"> • The RS485 network cable connections are polarity sensitive and must be connected the same way on every device (i.e. + to + and - to -). (See section 1.4.1 of this manual for details.) • Is the transmit LED flashing? The transmit LED will only flash when the device is responding to a poll. A unique address is required for each device on the network. Duplicate addresses will cause some or all of the devices on the network to quit working. (See section 1.6.1 of this manual for details.) • A unique IP address is required for each device on TCP/IP networks. Duplicate addresses will cause multiple devices to respond to the same poll. This will cause some or all of the devices on the network to quit working. (See section 1.6.2 of this manual for details.)

Reported Problem	Possible Solutions
Network communications are disrupted when the device is connected (cont.)	<ul style="list-style-type: none"> Shield drain connections should be daisy chained in the same manner as the signal cables for RS485. The shield drain wire should be left unterminated at the end of the cable and connected to earth only at the network master controller. Shield wires must not be connected to the RS485 connector on the D-100.
There are time out errors when polling the device.	<ul style="list-style-type: none"> What registers are you polling for? Polling for invalid registers will slow the response time. The range of valid integer registers is 40001 – 40068. The range of valid floating point registers is 41003 – 41081. Resetting totals requires the network controller to write a 1 to a register in our device. This takes longer to accomplish than simply reading registers. This can lead to time out issues. When dealing with time out errors, temporarily extend the allowable delay to see if the problem will go away.

D-100 FLOW DISPLAY MODBUS TCP/IP BOARD



Green - LED
Network
Activity

Yellow - LED
Network
Link

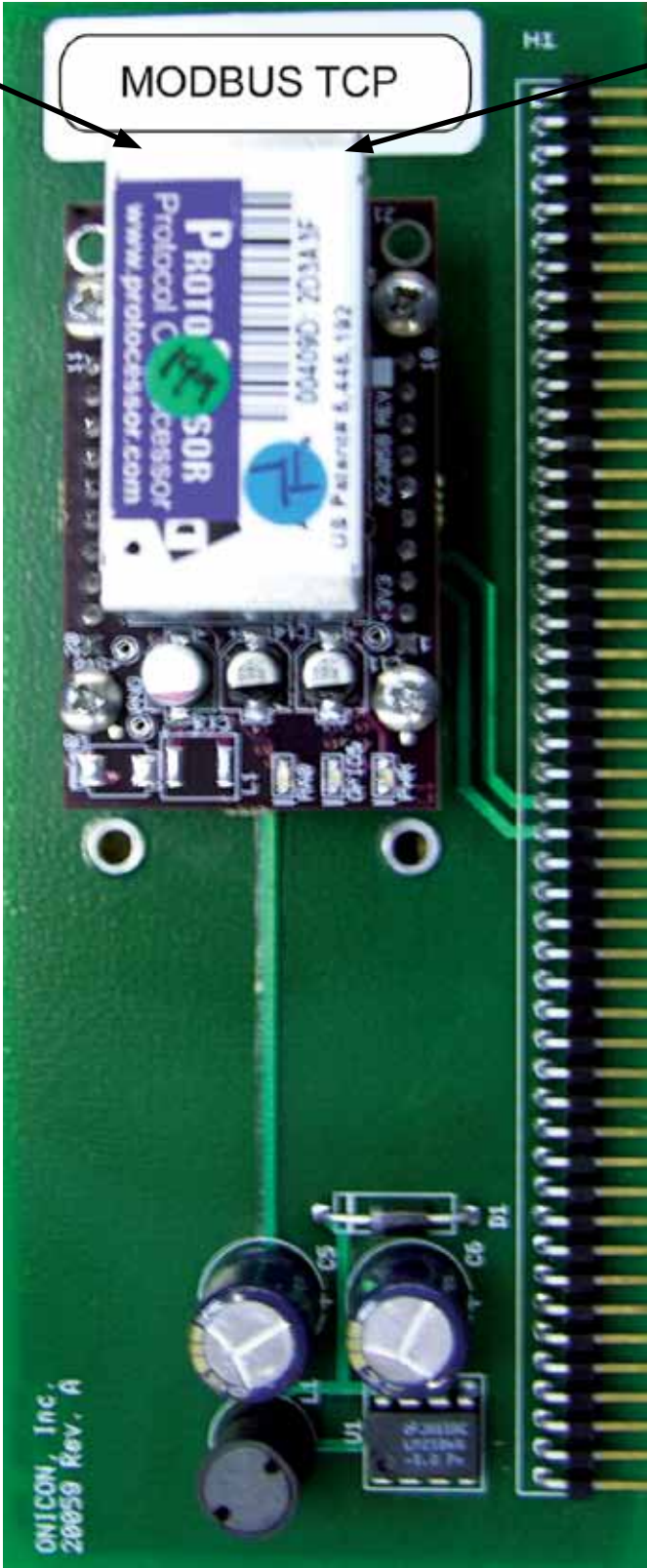

D-100 FLOW DISPLAY MODBUS RS485 BOARD

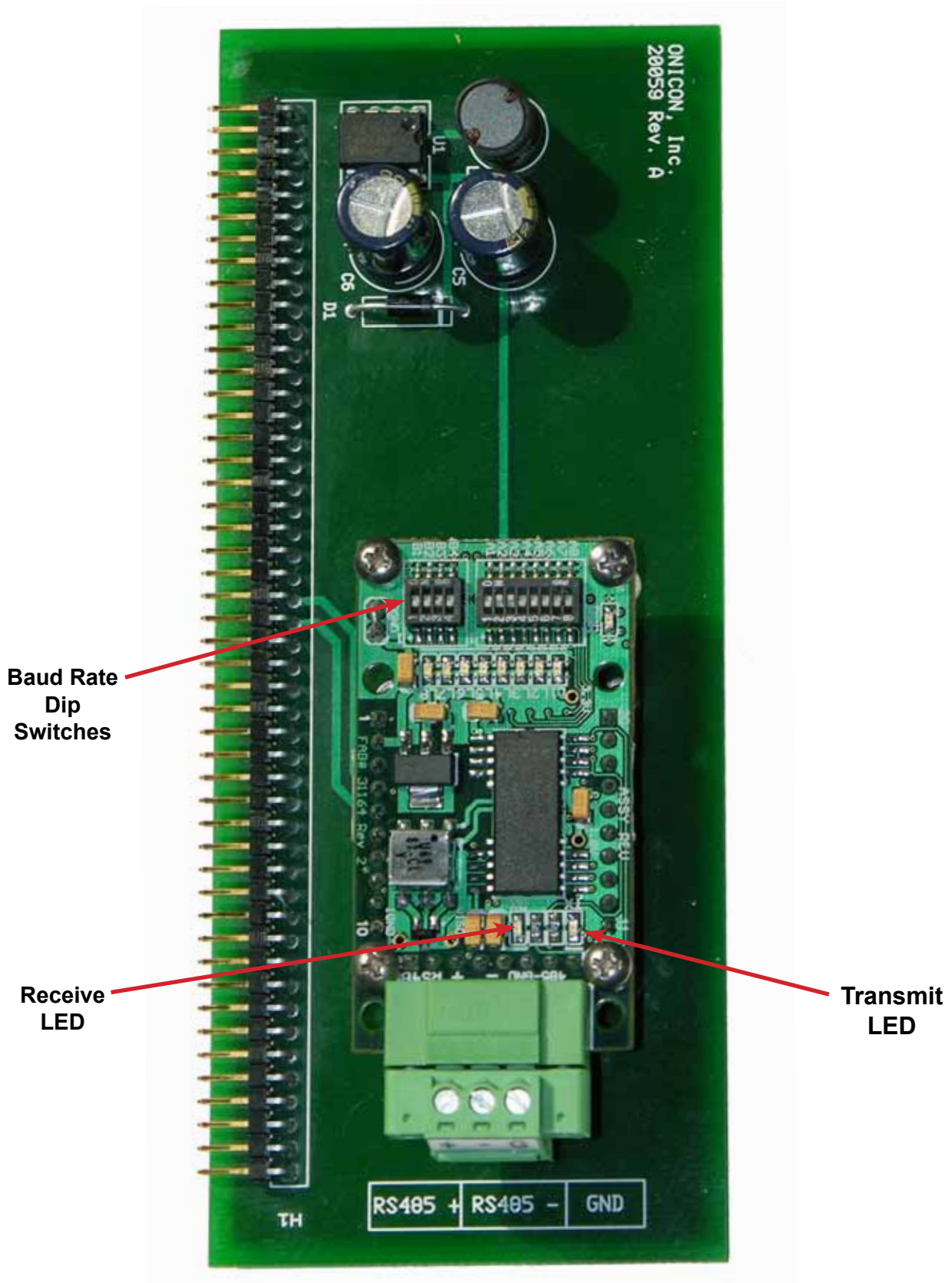

D-100-MOD MODBUS TCP Auxiliary Output Board



Aux Pulse Input Connector (T2)

RJ45 Connector (T1)

Pulse Type Selector Switch (S1)

Input Impedance Jumper (J1)

