

Installation Hardware Instructions for INSTL70, INSTL71 & INSTL72 High Pressure Hot Tap Installation Kit for Welded Steel Pipe



For F-5000 Series Insertion Thermal Mass Flow Meters

Kit #	INSTL70	INSTL71	INSTL72
Maximum Pressure (PSIG)	125	500	600
Maximum Temperature (°F)	200	140	600

This kit can be installed during a system shutdown or on a pressurized pipe. Once installed, this kit allows for insertion and removal of the flow meter without a system shutdown. For installations on a pressurized pipe, a hot tap drilling machine is used to create a 5/8" opening in the pipe wall.

Directions for installation during system shutdown:

1. Identify an appropriate location for the flow meter (see pages 2-3).
2. Weld the branch outlet onto the pipe.
3. Drill a 5/8" (minimum) access hole, centered in the branch outlet.
4. Install the close nipple, ball valve second close nipple, weldment and compression fitting as shown below; use a paste type thread sealant or Teflon® tape as needed.
5. Flush and pressurize the system.

Directions for installation in a pressurized system.

1. Identify an appropriate location for the flow meter (see pages 2-3).
2. Weld the branch outlet onto the pipe.
3. Install the close nipple and ball valve as shown below; use a paste type thread sealant or Teflon® tape as needed.
4. Use a hot tap drilling machine to create the 5/8" access hole.
5. Remove the drill and clear all debris out of the valve.
6. Install the second close nipple, weldment and compression fitting using paste type thread sealant or Teflon® tape as needed.

NOTE: Before installing the flow meter, read the entire installation manual.

Important Note

ONICON Insertion flow meters are precision measuring devices that must be installed according to the instructions contained in this document in order to maintain their accuracy and reliability. Failure to follow these instructions will result in erratic operation and reduced accuracy.

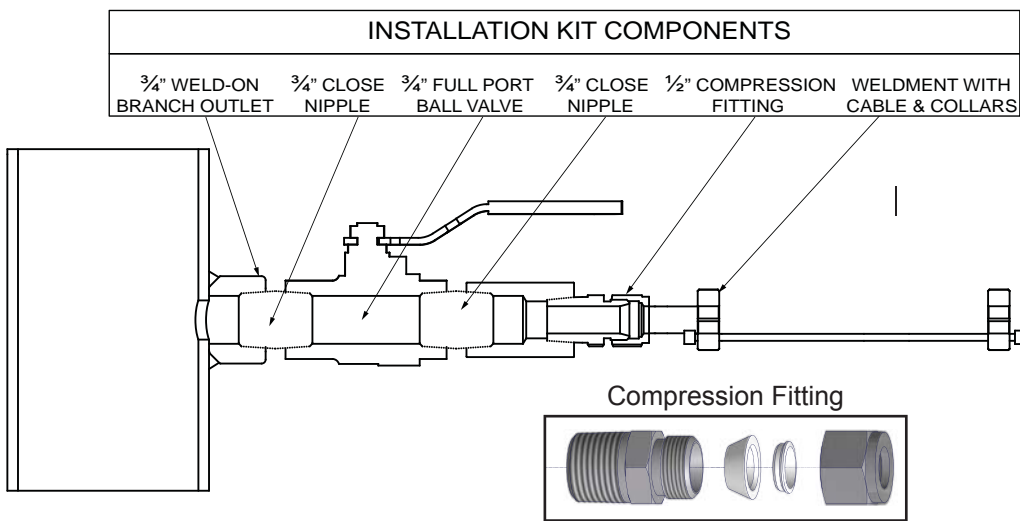

(Exploded view)

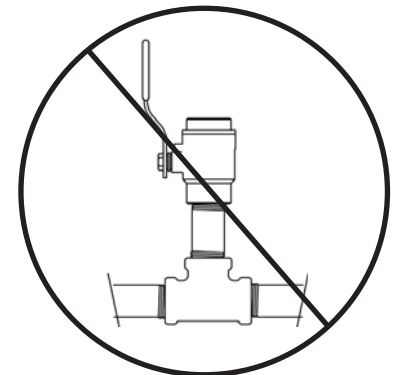

Do not substitute threaded tees for the welded branch outlet. Contact ONICON if you need installation hardware for threaded pipe.

FLOW METER SITE SELECTION GENERAL GUIDELINES

- For 1" and larger diameter pipes
- Install in vertical or horizontal pipe
- For horizontal pipe position meter anywhere in upper 180°

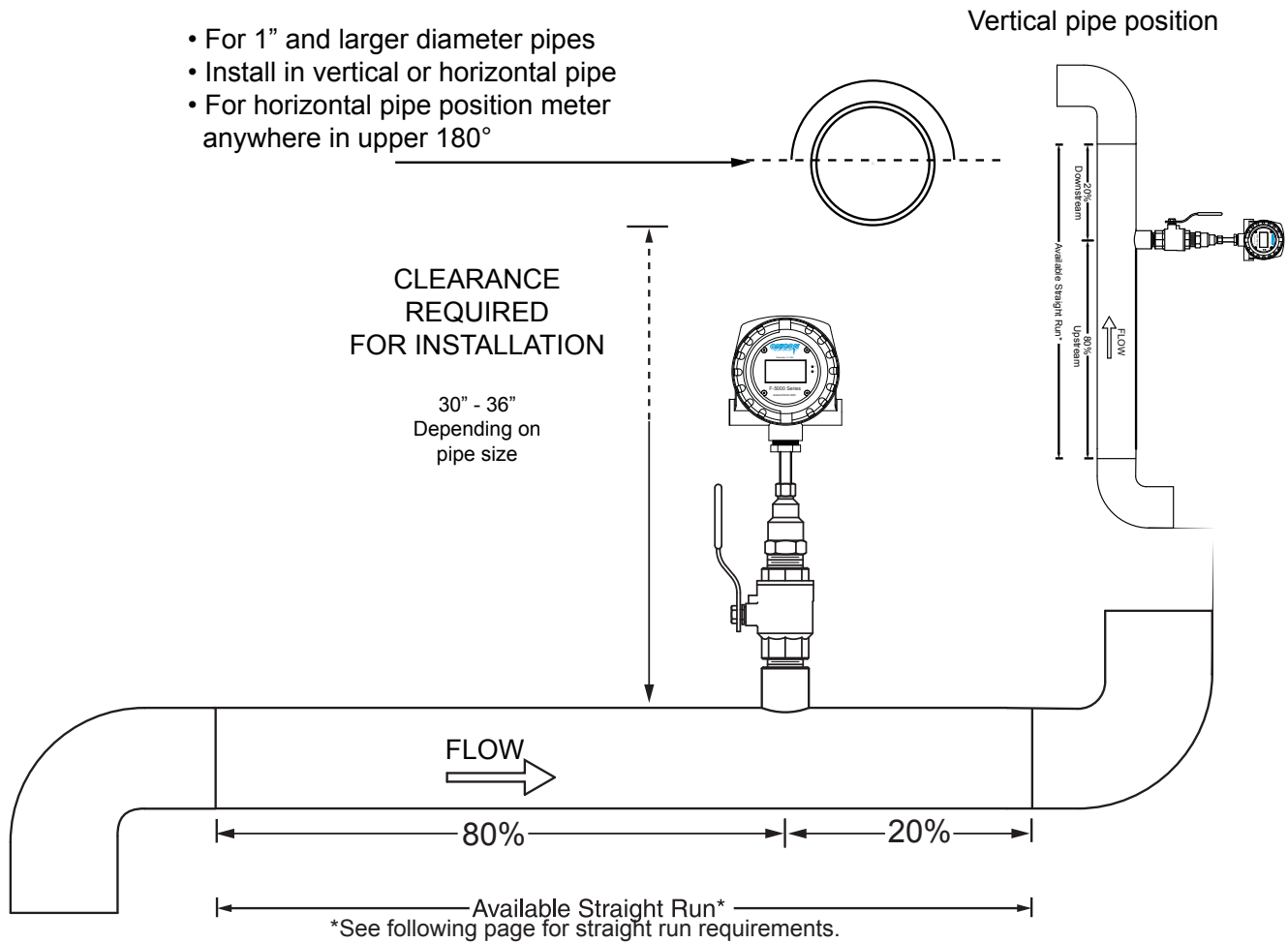

EVALUATING UPSTREAM PIPING CONDITIONS

Better ↑	Straight Pipe
	Single Bend
↓ Worse	Pipe Reduction
	Multiple Bends in Same Plane
	Pipe Expansions
	Tees
	Multiple Bends Out of Plane
	Modulating or Regulating Valve

How to determine the available straight pipe diameters:

For each application, locate the longest straight, unobstructed section of pipe (no bends, tees, valves, other insertion probes, size transitions). The longest straight pipe run in inches divided by nominal pipe size in inches equals "diameters of straight pipe."

STRAIGHT RUN REQUIREMENTS FOR INSERTION ELECTROMAGNETIC FLOW METERS

GENERAL PRACTICES:

1. For best results, install the flow meter in a straight run of pipe, free of bends, tees, valves, transitions and obstructions.
2. Straight run requirements vary based on the nature of the upstream obstruction. See the table below for guidelines in determining upstream straight run requirements based on the nature of the obstruction. Depending upon specific location details, more or less straight run may be required to produce a satisfactory flow profile.
3. If there is insufficient straight run, allow 80% of the run upstream and 20% of the run downstream. If the total length of straight run is less than 70% of the recommended distance, performance may seriously degrade, and consideration should be given to installing an ONICON flow conditioner.

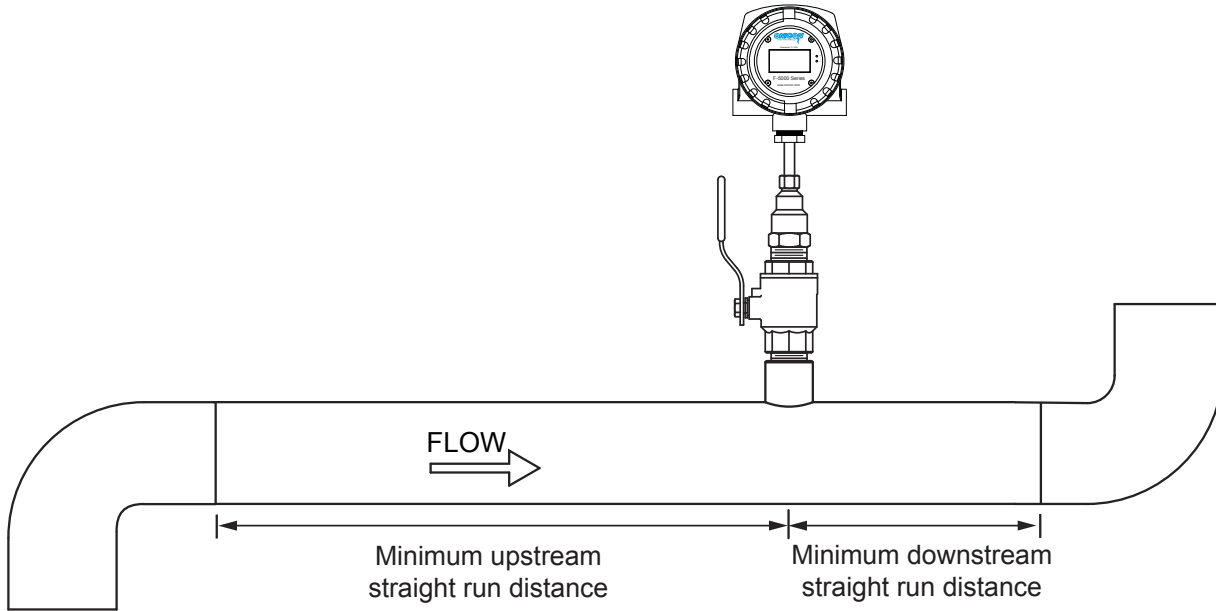

Upstream obstruction	Straight run required upstream of meter location	Straight run required upstream of meter location with flow conditioner	Straight run required downstream of meter location
Single bend preceded by ≥ 9 diameters of straight pipe	10 Diameters	3 Diameters	5 Diameters
Pipe size reduction in straight pipe run	10 Diameters	3 Diameters	5 Diameters
Multiple bends in plane with < 9 diameters of straight pipe between them	20 Diameters	5 Diameters	5 Diameters
Pipe size expansion in straight pipe run	20 Diameters	5 Diameters	5 Diameters
Tees	30 Diameters	5 Diameters	
Multiple bends out of plane	30 Diameters	9 Diameters	5 Diameters
Modulating or regulating valve	40 Diameters	10 Diameters	5 Diameters

IMPORTANT NOTE

Always use the maximum available straight run. When more than the minimum required straight run is available place the meter such that the excess straight run is upstream of the meter location.

NOTE TO INSTALLERS

Leave the compression nut FINGER TIGHT until the flow meter is installed. If the nut is too tight, the ferrules will deform.

