



Vortex flow meters detect the frequency of alternating low pressure vortices that are formed as flow is diverted around a bluff body. These swirling low pressure zones apply lateral pressure first to one side, then to the other side of the bluff body, which in turn causes the body to vibrate. The frequency of vibration is directly proportional to the flow velocity.

DESCRIPTION

The ONICON F-2500 Series Vortex Flow Meter is a flexible design that provides accurate, reliable flow measurement in a wide variety of demanding applications. A unique two stage bluff body/sensor design enhances signal sensitivity and extends the operating range of the meter while protecting the sensors from pressure shocks and solids suspended in the flow stream. The integral temperature sensor and optional pressure sensor allow for accurate direct mass flow measurement in steam and compensated flow measurement in compressed air and gases.

Operating as a loop powered device, each meter provides a 4 - 20 mA output signal for flow rate and a scalable pulse output for totalization. A built-in display provides flow rate and total data, instantaneous temperature, operating status and diagnostic data. Instantaneous pressure data is also provided for meters equipped with the optional pressure sensor. Digital data is available via Hart®.

APPLICATIONS

- Saturated steam
- Hot water to 464°F (240°C)

Applications with optional pressure sensor

- Superheated steam to 464°F (240°C)
- Compressed air
- Industrial gases

CALIBRATION

Each meter undergoes a 5-point calibration from 0 - 250 ft/sec (0 - 76 m/s). In addition, each meter is individually programmed using application specific data provided by the customer and arrives ready to install without the need for field programming.

FEATURES

- Mass flow measurement from a single instrument
- Integral 1,000Ω platinum RTD for precise temperature measurement
- Optional pressure transducer for accurate pressure readings at the meter location
- Loop powered operation
- Maintenance free non-moving parts design
- Wear resistant bluff body/sensor design
- Advanced signal processing algorithms ensure stable flow readings and reject noise.
- Easy-to-install meter arrives fully programmed and ready to use.

GENERAL SPECIFICATIONS

ACCURACY

Percent of reading accuracy to within:

- ± 0.75% for liquids (volumetric)
- ± 1% for steam and gases (volumetric)
- ± 1.5% for steam and gases (mass)

Re ≥ 20,000

Repeatability: ± 0.1%

Long term stability: ±0.1% over a period of 1 year

SENSING METHOD

- Vortex shedding with integral piezoelectric sensors.
- Integral 1,000Ω platinum RTD for instantaneous temperature.
- Pressure transducer (optional) provides instantaneous pressure.

GENERAL SPECIFICATIONS (cont.)



OPERATING TEMPERATURE RANGE

Ambient: -40°F (-40°C) to +185°F (+85°C)
 Medium: -40°F (-40°C) to 464°F (+240°C)

MAXIMUM OPERATING PRESSURE

≤ Flange rating or 1400psi (100 bar)

PRESSURE LOSS

Pressure loss varies with meter size and flow rate.
 Please contact ONICON for detailed information.

CONNECTION TYPE

- ANSI Class 150 Flange
- ANSI Class 300 Flange
- ANSI Class 600 Flange
- Wafer style

MATERIALS

- Sensor Body: 316L Stainless Steel
- Bluff/Sensor Body: 316L Stainless Steel
- Electronics Enclosure: Epoxy painted aluminum

ENCLOSURE

NEMA 6 (IP67)

DISPLAY

2 line, 10 character alphanumeric LCD

OUTPUT SIGNALS PROVIDED

- Rate: 2-wire, 4 - 20 mA, 14 - 36 VDC, maximum resistance: $R \leq ((V_{supply} - 14V) / 22 \text{ mA})$
- Totalization: 2-wire, scaled pulse, 0.5Hz, 30VDC and 100 mA maximum
- Digital: Hart®, FSK

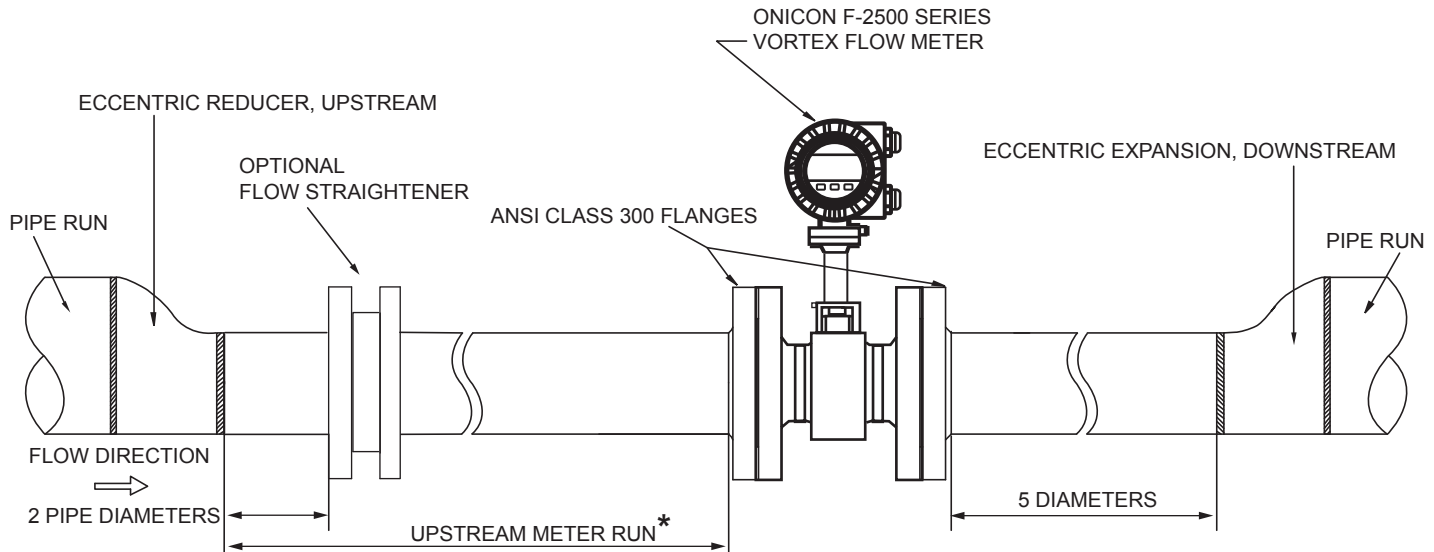

Model # Codification = F-25AA - BCD

F = Flow Meter

B = Wafer or Flange Connection

25 = In-line Vortex Meter

- 0 = Wafer
- 1 = ANSI Class 150 Flange
- 3 = ANSI Class 300 Flange
- 6 = ANSI Class 600 Flange

AA = Diameter in Inches

- 05 = 1/2" 04 = 4"
- 01 = 1" 06 = 6"
- 15 = 1.5" 08 = 8"
- 02 = 2" 10 = 10"
- 03 = 3" 12 = 12"

C = Compact or Remote Mount

- 1 = Compact Mount
- 2 = Remote Mount

D = Pressure Compensation

- 0 = None
- 1 = Pressure Compensation

Obstruction	* Minimum upstream pipe run required		** Minimum downstream run required
	Without flow straightener	With flow straightener	
Single 90	20 Dia	12 Dia	≥ 5 diameters
Tee	20 Dia	12 Dia	
RDCR/EXPNDR	20 Dia	12 Dia	
Two 90's Same Plane	30 Dia	17 Dia	
Ball/Gate Valve Fully Open	30 Dia	17 Dia	
Two 90's Out of Plane	40 Dia	22 Dia	
Control Valve	50 Dia	27 Dia	≥ 5 diameters
P.R.V.	50 Dia	27 Dia	

1500 North Belcher Road, Clearwater, FL 33765 • Tel (727) 447-6140 • Fax (727) 442-5699