

Installation Hardware Instructions
Hot Tap Installation Kit for Applications Requiring Pipe Saddles
 For F-3500 Series Insertion Electromagnetic Flow Meters



**For Use With Kits: INSTL19, INSTL20, INSTL22, INSTL23, INSTL24,
 INSTL25, INSTL26, INSTL27, INSTL28, INSTL29, INSTL30, INSTL75**

This kit can be installed on a pressurized pipe. A hot tap drilling machine is used to create a one inch opening in the pipe wall. Once installed, this kit allows for insertion and removal of the flow meter without a system shutdown.

Directions:

1. Identify an appropriate location for the flow meter (see pages 2-3).
2. Clamp the saddle onto the pipe; refer to manufacturer's instructions.
3. Install the close nipple and ball valve as shown below; use a paste type thread sealant or use Teflon® tape.
4. Use a hot tap drilling machine with a 1" hole saw to drill the access hole.
5. Remove the drill; then flush all debris out of the valve.
6. Use the 1" reducer provided in this kit when installing the flow meter

Important Note

ONICON Insertion flow meters are precision measuring devices that must be installed according to the instructions contained in this document in order to maintain their accuracy and reliability. Failure to follow these instructions will result in erratic operation and reduced accuracy.

NOTE: Before installing the flow meter, read the entire installation manual.

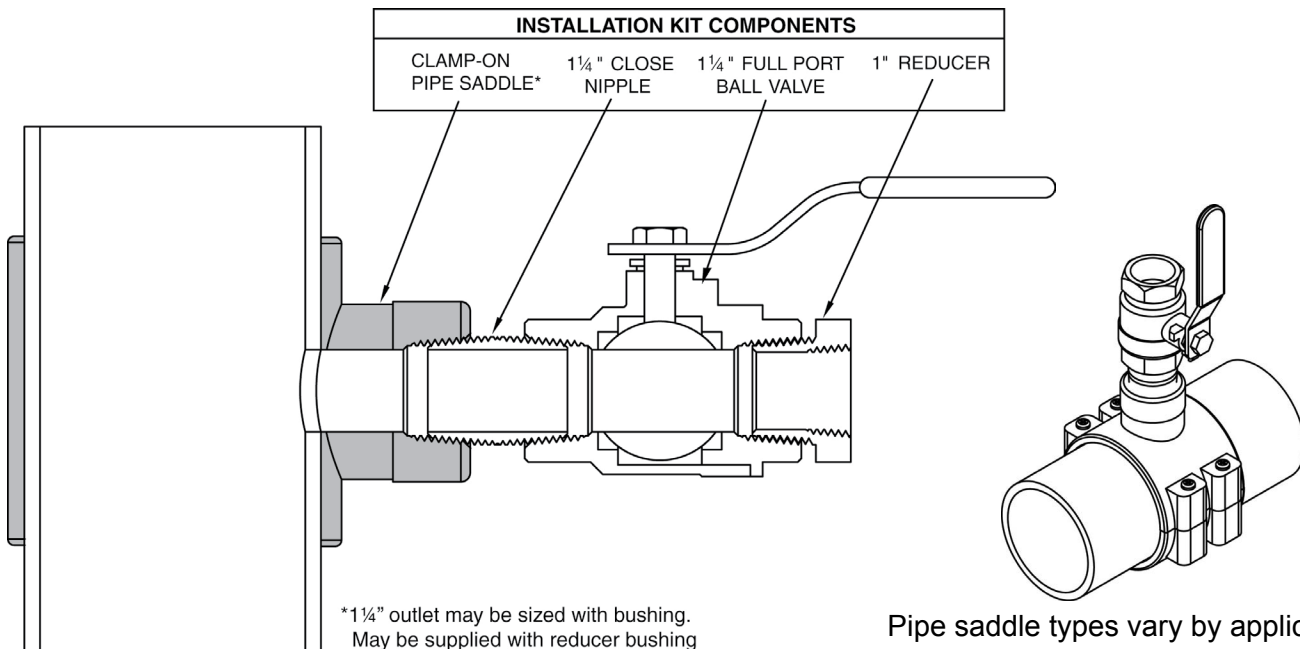

Important Note

ONICON provides pipe saddles to facilitate the installation of our flow meters. These saddles are purchased from leading manufacturers who provide quality products. Separate installation instructions accompany the saddle. Please follow these instructions when installing the saddle, with particular attention to bolt torque specifications.

FLOW METER SITE SELECTION GENERAL GUIDELINES



- For 3" and larger diameter pipes
- Install in vertical or horizontal pipe
- For horizontal pipe position meter anywhere in upper 240°

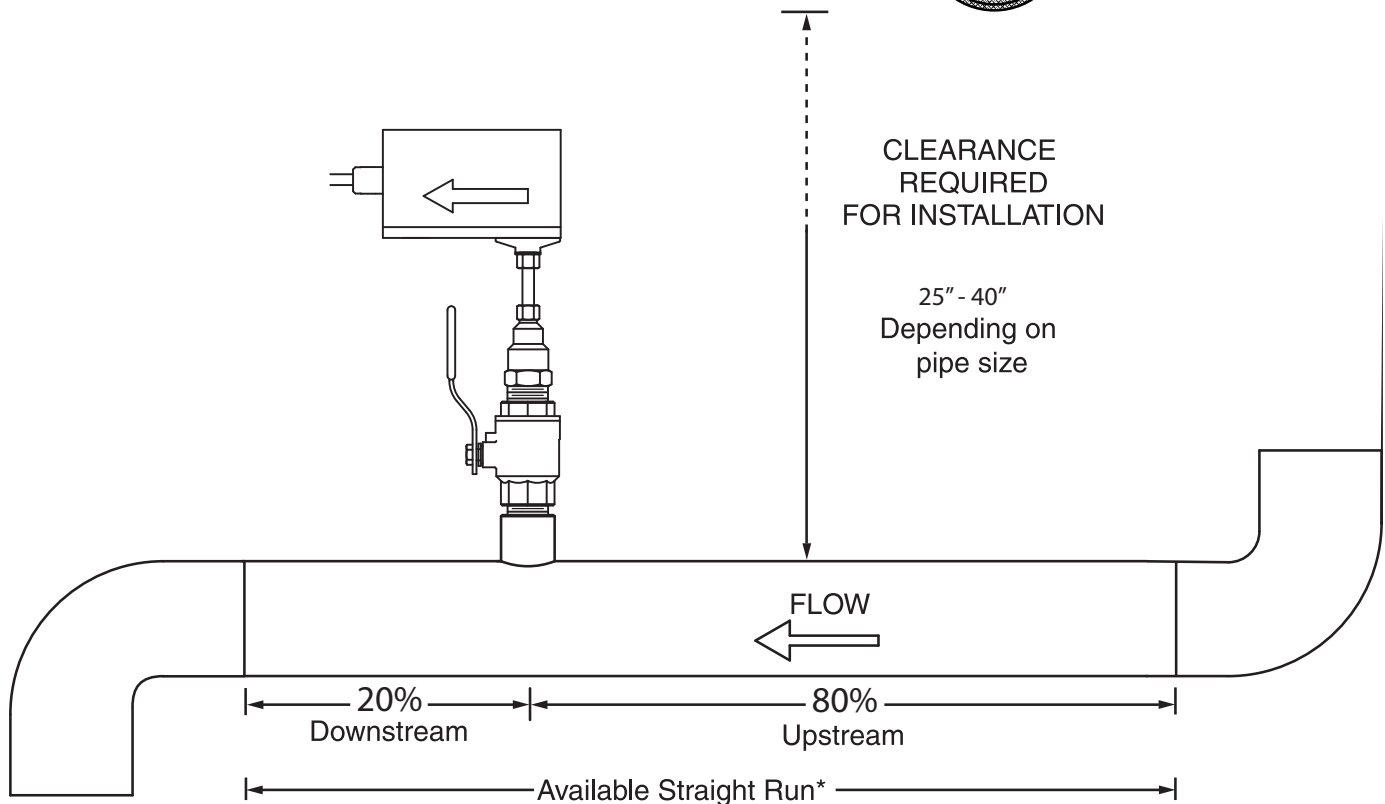
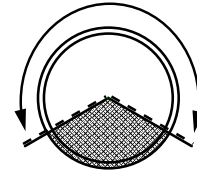

*See following page for straight run requirements.

EVALUATING UPSTREAM PIPING CONDITIONS

Better ↑ ↓ Worse	Straight Pipe
	Single Bend
	Pipe Reduction or Enlargement
	Outflowing Tees
	Multiple Bends in Same Plane
	Multiple Bends Out of Plane
	Inflowing Tees
	Control Valve

How to determine the available straight pipe diameters:

For each application, locate the longest straight, unobstructed section of pipe (no bends, tees, valves, other insertion probes, size transitions). The longest straight pipe run in inches divided by nominal pipe size in inches equals "diameters of straight pipe." For closed loop applications, consider both the supply and return lines as possible locations.

STRAIGHT RUN REQUIREMENTS FOR INSERTION ELECTROMAGNETIC FLOW METERS



GENERAL PRACTICES:

1. For best results, install the flow meter in a straight run of pipe, free of bends, tees, valves, transitions and obstructions.
2. Straight run requirements vary based on the nature of the upstream obstruction. See the table below for guidelines in determining upstream straight run requirements based on the nature of the obstruction.
3. If there is insufficient straight run, allow 80% of the run upstream and 20% of the run downstream. If the total length of straight run is less than 70% of the recommended distance, performance may seriously degrade, and consideration should be given to changing to the series F-3000 In-line Electromagnetic flow meter.

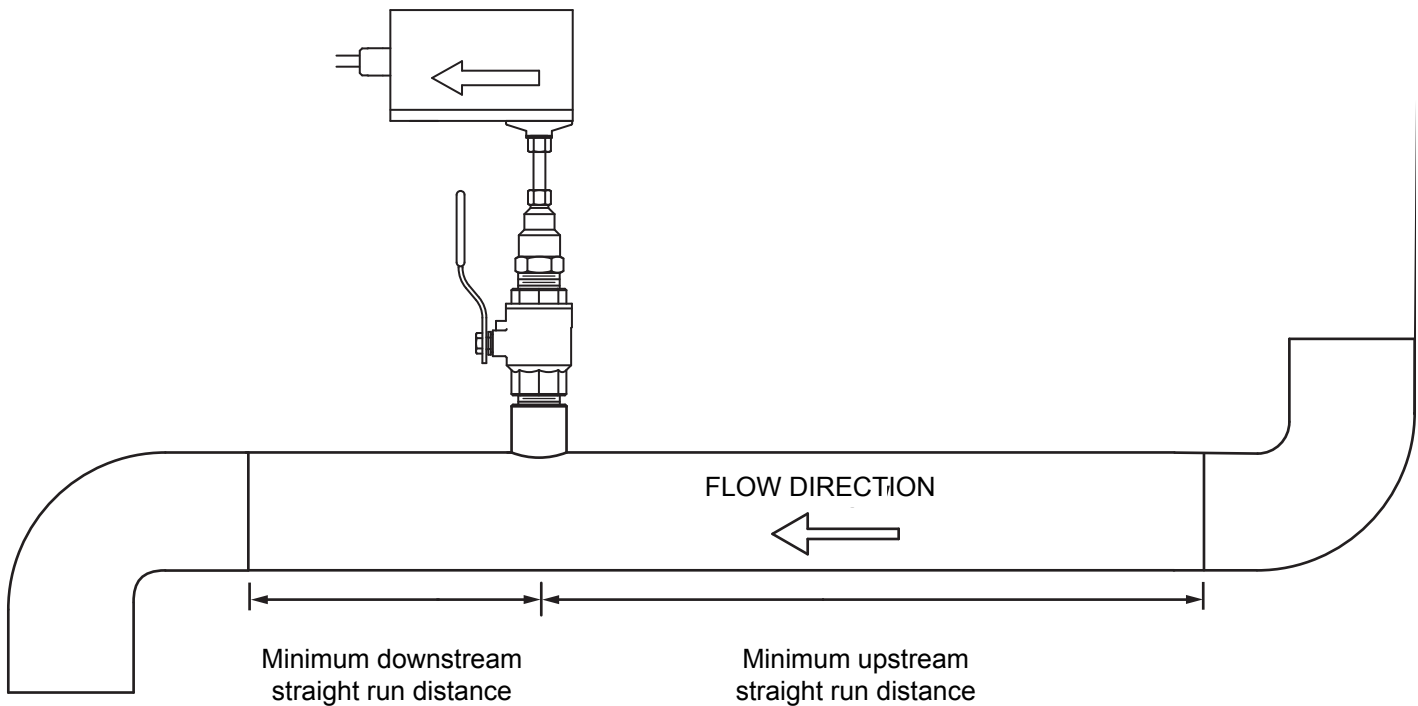

Upstream obstruction	Straight run required upstream of meter location	Straight run required downstream of meter location
Single bend preceded by ≥ 9 diameters of straight pipe	10 Diameters	5 Diameters
Pipe size reduction / expansion in straight pipe run	10 Diameters	5 Diameters
Single bend preceded by ≤ 9 diameters of straight pipe	15 Diameters	5 Diameters
Outflowing tee / Pump outflow	20 Diameters	5 Diameters
Multiple bends out of plane	30 Diameters	5 Diameters
Modulating valve	30 Diameters	5 Diameters

IMPORTANT NOTE

Always use the maximum available straight run. When more than the minimum required straight run is available place the meter such that the excess straight run is upstream of the meter location.



1500 North Belcher Road, Clearwater, FL 33765 • Tel (727) 447-6140 • Fax (727) 442-5699
www.onicon.com • customerservice@onicon.com