

Installation Hardware Instructions

Standard Installation Kit for Welded Steel Pipe

For F-1100, F-1200 & FB-1200 Series Insertion Turbine Flow Meters



For Use With Kits: INSTL1, INSTL5, INSTL18

This kit must be installed prior to filling the system, or into a section of pipe that is isolated from pressure and flow. Once installed, this kit allows for insertion and removal of the flow meter without a system shutdown.

Directions:

1. Identify an appropriate location for the flow meter (see pages 2-4).
2. Weld the branch outlet onto the pipe.
3. Drill a one inch (minimum) access hole, centered in the branch outlet.
4. Install the close nipple and ball valve as shown below. Use a paste type thread sealant. **DO NOT** use Teflon® tape.
5. Flush and fill the system.

NOTE: Before installing the flow meter, read the entire installation manual.

Important Note

ONICON insertion flow meters are precision measuring devices that must be installed according to the instructions contained in this document in order to maintain their accuracy and reliability. Failure to follow these instructions will result in erratic operation and reduced accuracy.

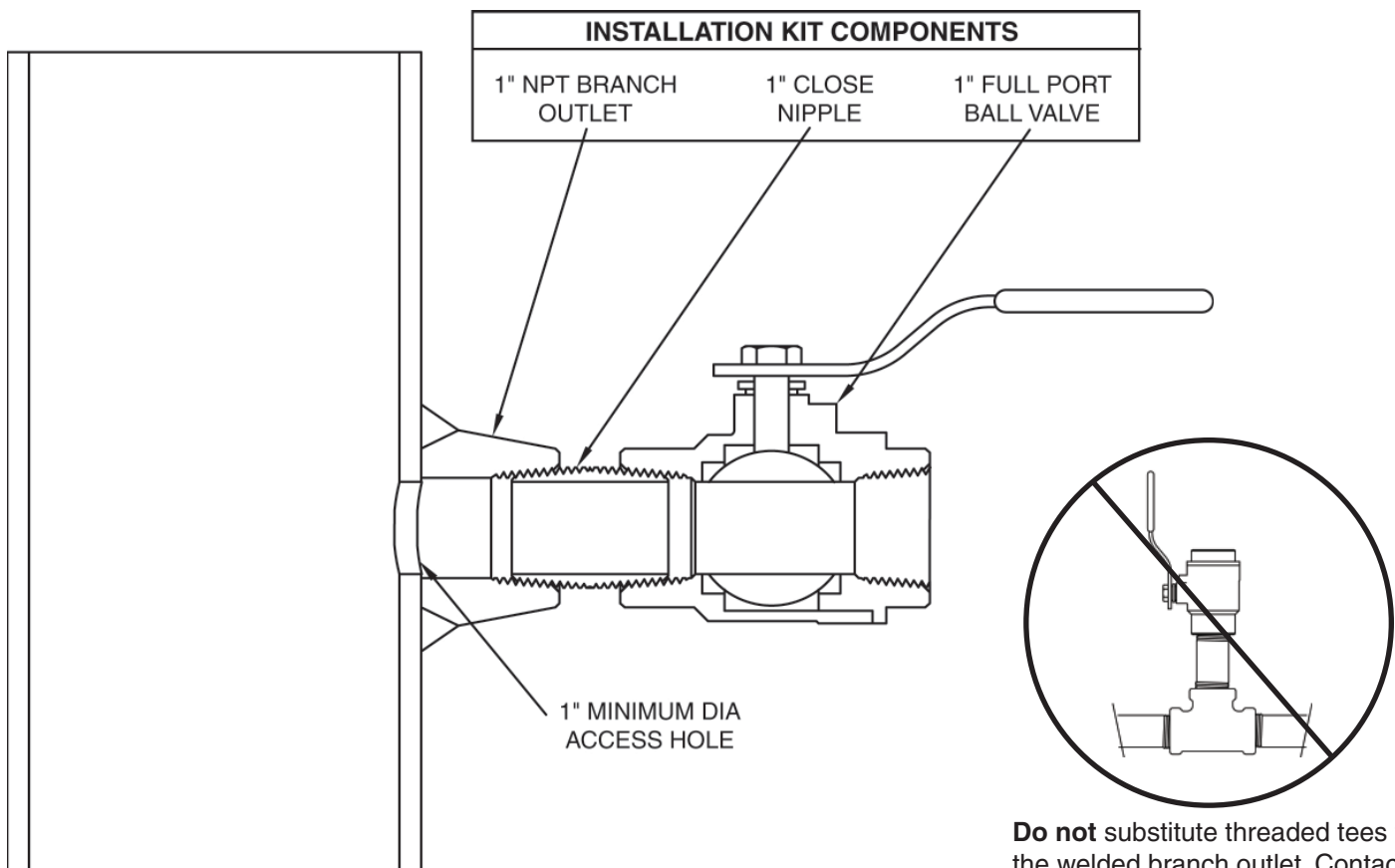

FLOW METER SITE SELECTION GENERAL GUIDELINES

- Install in vertical or horizontal pipe
- For horizontal pipe position meter anywhere in upper 240°

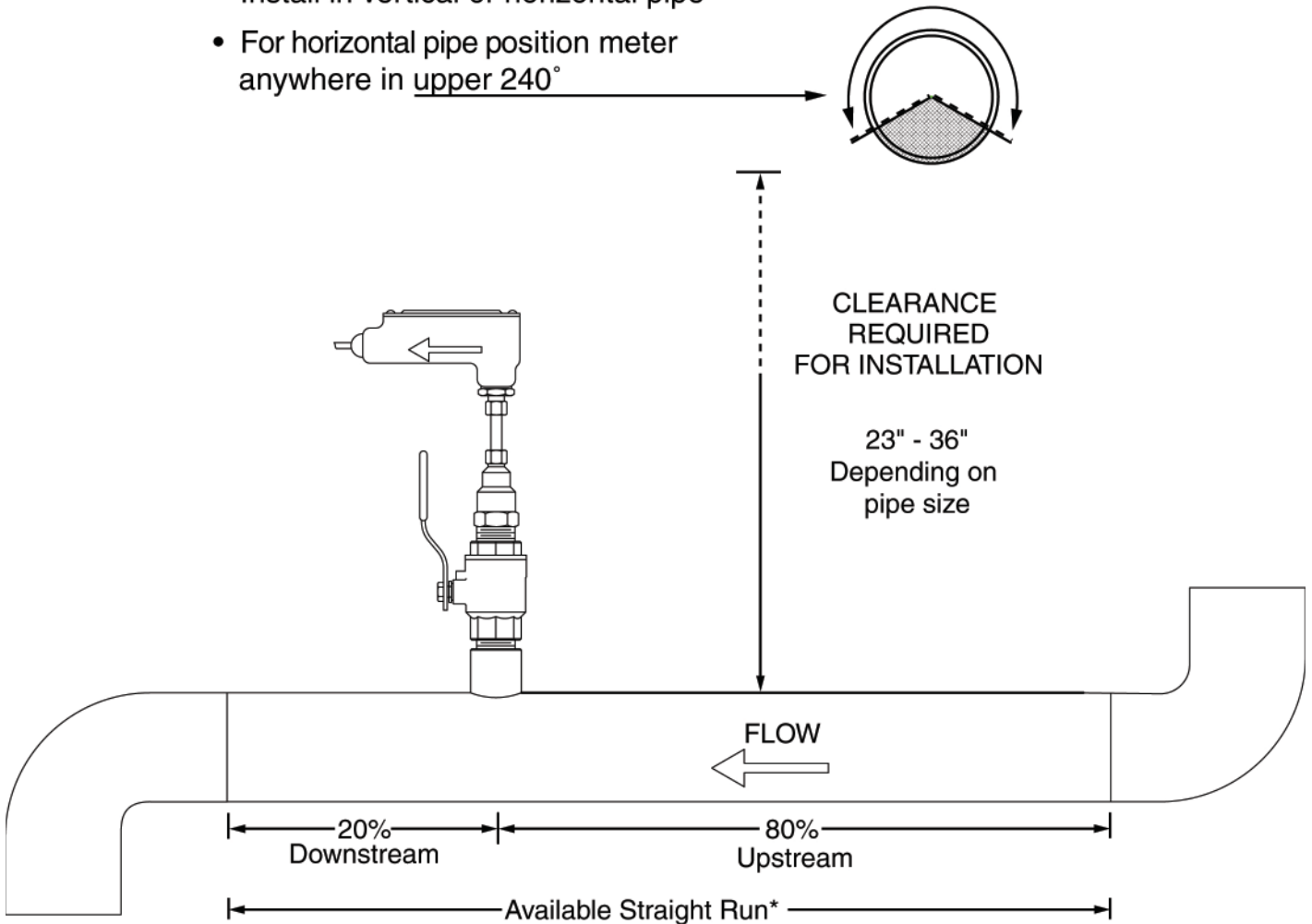

*See following pages for model specific straight run requirements.

EVALUATING UPSTREAM PIPING CONDITIONS

Better ↑ ↓ Worse	Straight Pipe
	Single Bend
	Pipe Reduction or Enlargement
	Outflowing Tees
	Multiple Bends in Same Plane
	Multiple Bends Out of Plane
	Inflowing Tees
	Control Valves

How to determine the available straight pipe diameters:

For each application, locate the longest straight, unobstructed section of pipe (no bends, tees, valves, other insertion probes, size transitions). The longest straight pipe run in inches divided by nominal pipe size in inches equals "diameters of straight pipe." For closed loop applications, consider both the supply and return lines as possible locations.

DETERMINING WHICH FLOW METER STRAIGHT RUN REQUIREMENTS TO USE

The label on the flow meter installation hardware kit package identifies the flow meter model number and the pipe diameter range for the kit. Confirm that the kit is appropriate for the actual pipe diameter and use the straight run requirements for the flow meter model number identified on the label.

- F-1100 series flow meters must be installed in 1¼" or larger diameter pipes.
- F-1200 series flow meters must be installed in 2½" or larger diameter pipes.

Refer to the information provided below if the kit is provided without identifying a specific flow meter model number.

- Refer to the label on the installation hardware for the pipe diameter range appropriate for the kit. Confirm that the actual pipe diameter is within the range of the kit provided.
- Assume model F-1100 series flow meters for pipe diameters between 1¼" and 2½".
- For kits provided for pipe diameters ≥ 2.5 " that do not specify a flow meter model number, assume F-1100 series straight run requirements.

STRAIGHT RUN REQUIREMENTS FOR INSERTION TURBINE FLOW METERS

Series F-1100 Single Turbine Flow Meters

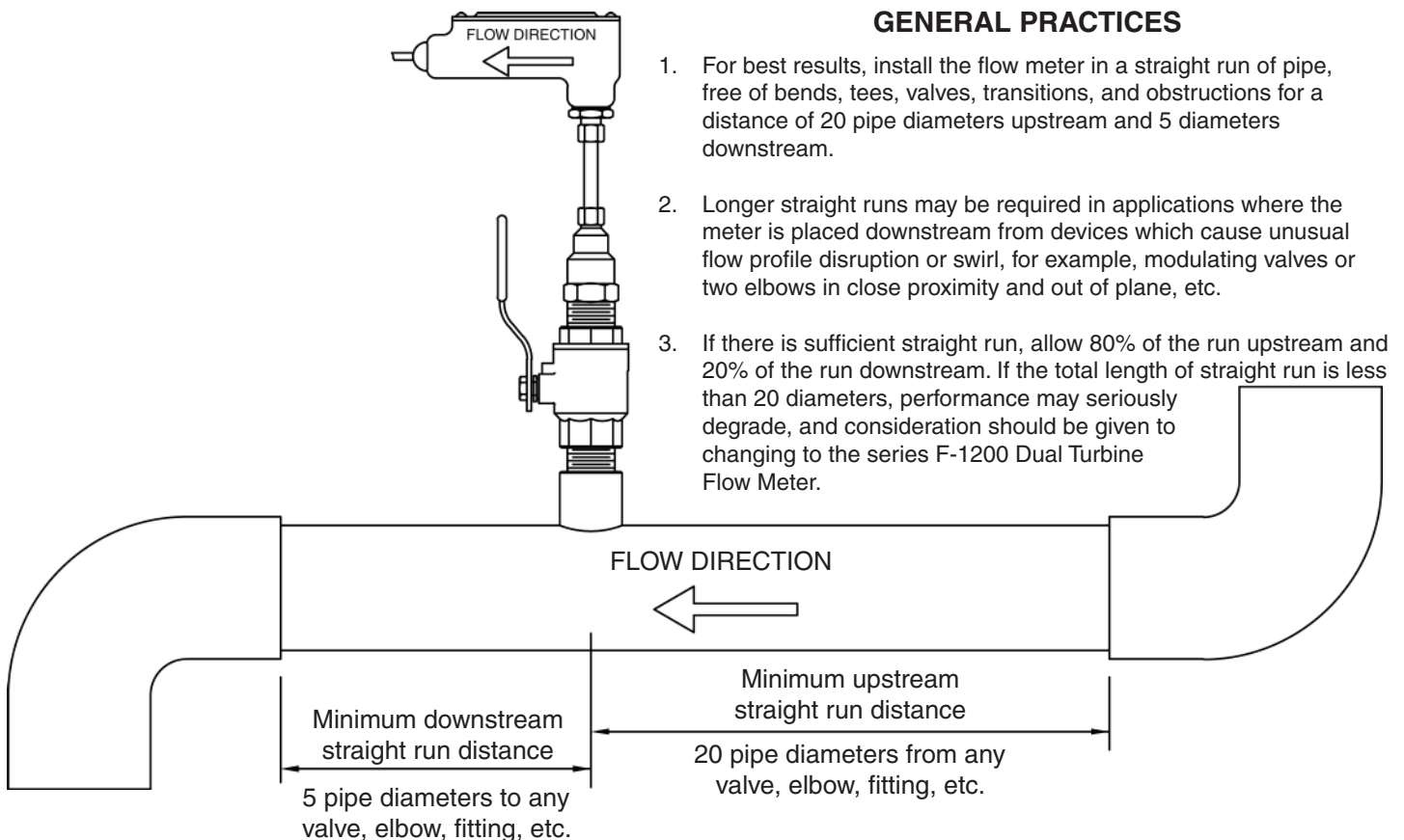

Series F-1200 Dual Turbine Flow Meters

GENERAL PRACTICES

1. For best results, install the flow meter in a straight run of pipe, free of bends, tees, valves, transitions, and obstructions for a distance of 10 pipe diameters upstream and 5 diameters downstream.
2. Longer straight runs may be required in applications where the meter is placed downstream from devices which cause unusual flow profile disruption or swirl, for example, modulating valves or two elbows in close proximity and out of plane, etc.
3. If there is sufficient straight run, allow 80% of the run upstream and 20% of the run downstream. If the total length of straight run is less than 12 diameters, performance may degrade.

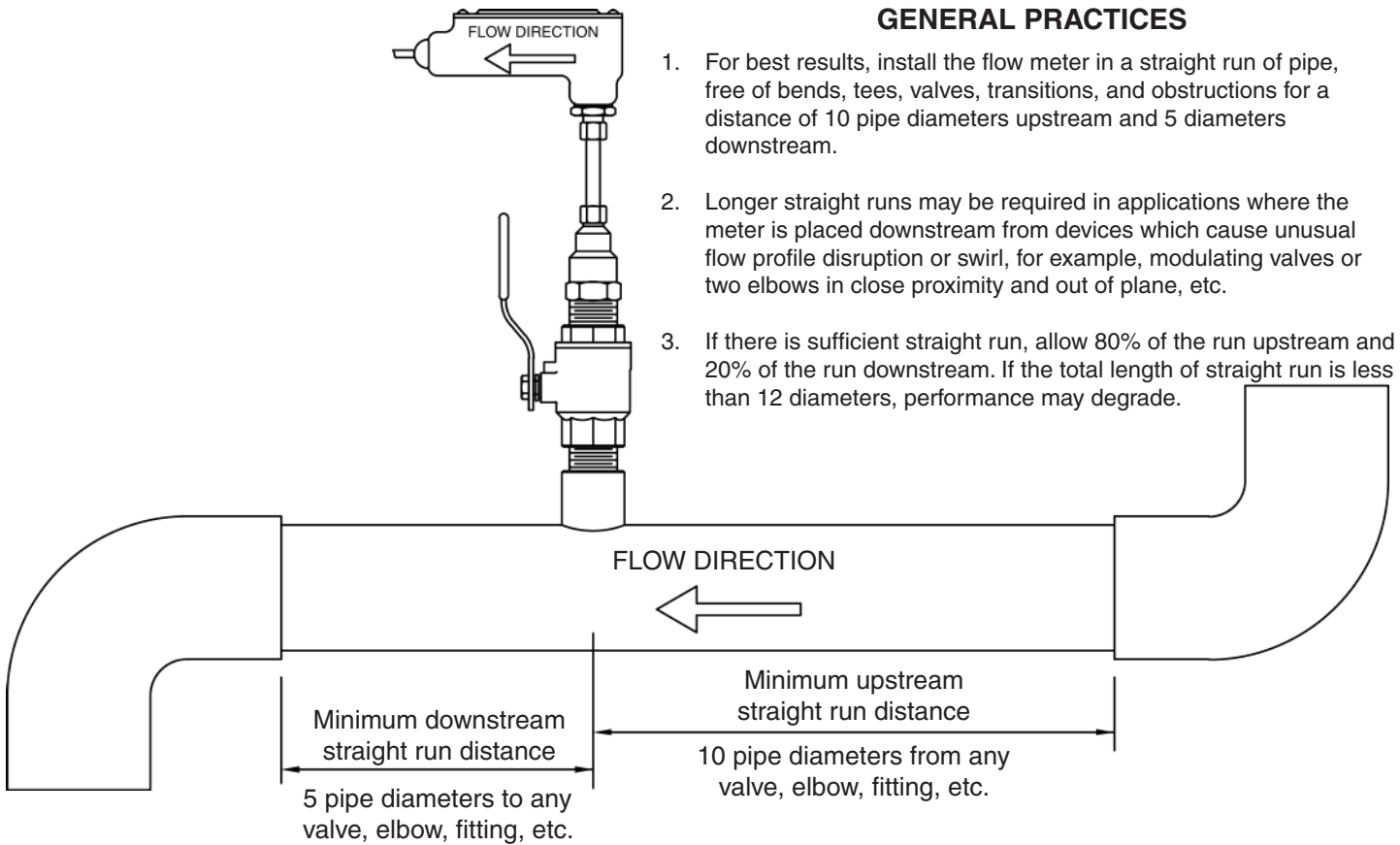

Series FB-1200 Dual Turbine Flow Meters Bi-Directional Flow Applications

GENERAL PRACTICES

1. For best results, install the flow meter in a straight run of pipe, free of bends, tees, valves, transitions, and obstructions for a distance of 10 pipe diameters on each side of the flow meter.
2. Longer straight runs may be required in applications where the meter is placed downstream from devices which cause unusual flow profile disruption or swirl, for example, modulating valves or two elbows in close proximity and out of plane, etc.
3. If there is sufficient straight run, allow 50% of the run upstream and 50% of the run downstream. If the total length of straight run is less than 20 diameters, performance may degrade.

