

F-2200 Series Steam Meter

Vortex Mass Flow Meter for Saturated Steam



Accurate cost effective
mass flow measurement
for saturated steam
in a **single instrument**

ONICON
INCORPORATED



DESCRIPTION



The ONICON F-2200 Series Steam Meter is designed for accurate, cost effective mass flow measurement of saturated steam. Utilizing advanced vortex sensing technology, the F-2200 is equipped with internal density compensation providing highly accurate direct mass flow measurement. Operating as a loop powered device, each meter provides a 4 – 20mA analog output, a scaled pulse output, and a built-in local display.

ONICON's F-2200 Series Steam Meter offers a simplified, cost effective alternative to the use of expensive mass flow computers and a dramatic improvement in accuracy, especially when compared to uncompensated meters.

FEATURES

Provides Direct Mass Flow Measurement for Saturated Steam – the use of a precision platinum RTD and the ability to perform complex density calculations allow the meter to provide a direct mass flow measurement without the need for a separate mass flow computer with external temperature and pressure transmitters.

Highly Accurate – mass flow measurement accuracy for saturated steam exceeds 1.5% of reading in the most common pipe sizes.

Simple Installation and Commissioning – loop powered design simplifies wiring and signal processing. Additionally, each meter is factory programmed and ready for use upon delivery. The built-in user interface provides access to all programming functions, including a comprehensive self diagnostic capability. This self diagnostic function can detect bi-phase flow and flow rates outside the programmed operating parameters. It can also identify common installation problems.

State-of-the-Art Vortex Flow Sensing – the use of titanium in the construction of the shedder bar offers both improved durability and improved sensitivity. Titanium is stronger, lighter and more flexible than steel. Durability is improved by using a stronger more flexible material. Lighter weight and increased flexibility also improve the ability to sense the lower amplitude vortices associated with low velocity flow.

Advanced Signal Processing Enhances Accuracy– every meter is supplied with advanced filtering algorithms. These algorithms allow the meter to establish continuous real-time norms for signal strength and quality. Sudden changes to the anticipated strength or quality of the incoming signal is rejected as noise. Additional signal processing cancels out the effect of common mode noise. Common mode noise is the type of noise most often associated with vibration in the piping system.

CALIBRATION

Individually Calibrated and Programmed for Each Application - every meter undergoes a 5 point calibration from 0-250 ft/sec. In addition, each meter is individually programmed using application specific data supplied by the customer.

● SPECIFICATIONS

Accuracy*

- 1" - 8" Diameter
 - Volumetric Flow: ±1% of Reading
 - Mass Flow: ±1.5% of Reading
- 3/8" - 3/4" Diameter
 - Volumetric Flow: ±2% of Reading
 - Mass Flow: ±2.5% of Reading

*Applies to entire operating range, see table below

Sensing Method

Vortex shedding using a titanium shedder body with integral piezoelectric pressure sensors and an integral 1000 ohm platinum RTD.

Meter Size Range

3/8" to 8" diameter

Maximum Temperature

Medium: 464° F
Ambient: 140° F

Maximum Operating Pressure

Standard: 300 PSI
Optional: 600 PSI

Pressure Loss

Varies with meter size, density and flow rate. Please contact ONICON for detailed information

Output Signals Provided

Rate: Loop powered 4-20 mA signal for mass flow
Total: Scaled pulse output, open collector

Supply Voltage

Standard (loop powered, 2 wire connection):
14 to 36 volts DC, 20 mA maximum

Materials

Housing:
3/8" to 4": Stainless Steel, 316 L
6" to 8": Stainless Steel, 304
Vortex Shedding Body: Unalloyed Titanium
Seal for Shedding Body: Inconel, Nickel Plated
Electronics Enclosure: Cast Aluminum, NEMA 4X

Display

2 Line Dotmatrix LCD

Specifications are subject to change without notice.

● FLOW RANGES (lbs/hr) FOR SATURATED STEAM

at various pressures (psig) and densities (lb/ft³)

Meter Size inches	Model Number	ID inches	15 PSIG		30 PSIG		50 PSIG		75 PSIG		100 PSIG		150 PSIG		300 PSIG	
			0.072 lbs/ft ³		0.106 lbs/ft ³		0.150 lbs/ft ³		0.204 lbs/ft ³		0.257 lbs/ft ³		0.363 lbs/ft ³		0.679 lbs/ft ³	
			min	max	min	max	min	max	min	max	min	max	min	max	min	max
3/8"	F-2204	0.50	12.4	85.3	16.1	108	20.5	128	25.6	149	30.3	168	39.2	199	63.4	273
1/2"	F-2205	0.59	14.5	119	18.8	151	23.9	179	29.8	209	35.4	235	45.7	279	74	381
3/4"	F-2208	0.82	20.2	235	26.2	296	33.3	352	41.6	411	49.3	461	63.8	548	103	750
1"	F-2210	1.05	31.3	383	40.5	563	51.6	797	64.4	1083	76.4	1219	98.8	1448	160	1982
1 1/2"	F-2215	1.61	73.5	898	95.1	1321	121	1869	151	2541	179	2860	232	3398	375	4650
2"	F-2220	2.07	122	1486	157	2184	200	3091	250	4203	297	4730	383	5621	620	7692
3"	F-2230	3.07	267	3268	346	4803	441	6798	550	9243	652	10402	843	12360	1364	16914
4"	F-2240	4.03	461	5632	596	8278	759	11716	948	15930	1124	17928	1453	21302	2351	29151
6"	F-2260	6.07	1045	12771	1352	18772	1722	26568	2149	36123	2549	40653	3295	48306	5331	66103
8"	F-2280	7.98	1806	22068	2337	32437	2976	45909	3713	62420	4405	70248	5693	83471	9212	114225

APPLICATIONS

- Central Plant Steam Output
- Individual Boiler Monitoring
- Campus Steam Distribution
- Sub-metering for Tenant Billing
- Cogeneration & Heat Recovery
- Hot Water Generators
- Absorption Chillers
- Process Heating



The use of titanium in the construction of the shedder bar offers both improved durability and improved sensitivity.

TYPICAL STEAM INSTALLATION DRAWING

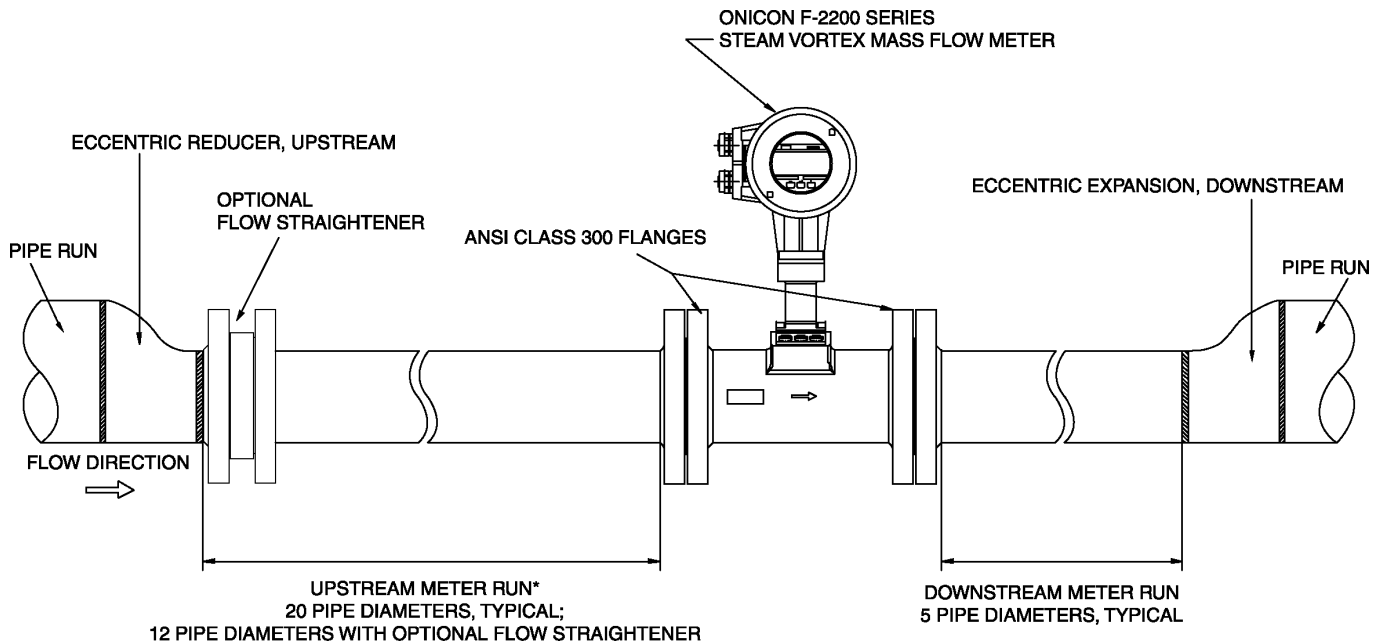

*Upstream meter run requirements vary according to entering conditions. Please see installation manual for installation recommendations based on specific piping configurations.

• • • DIMENSIONS AND WEIGHTS

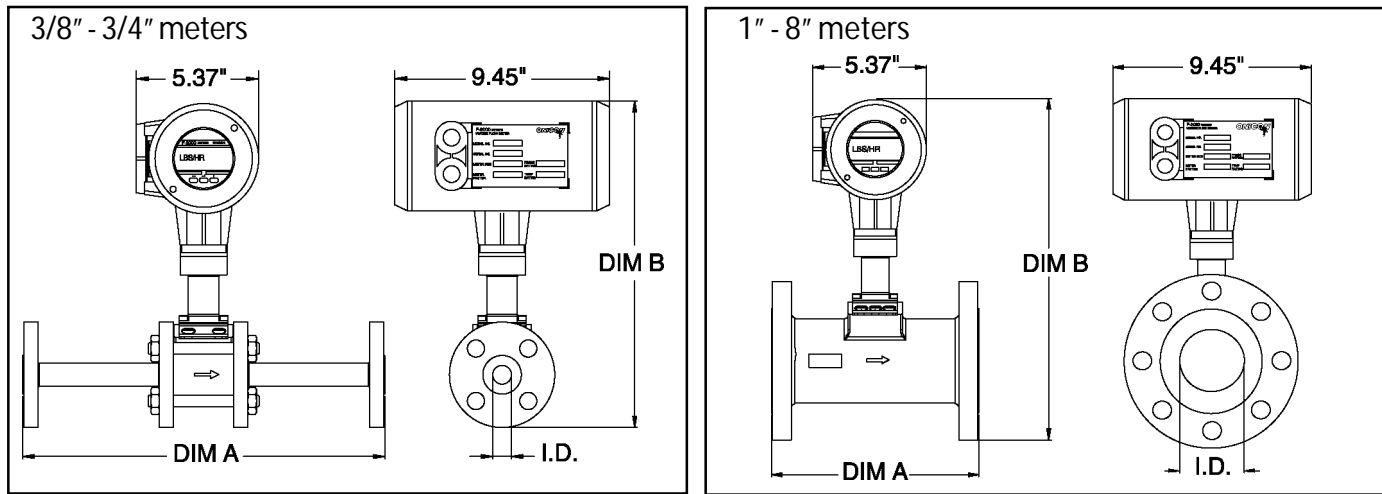

Meter Size	Model	Dimensions			Approximate Meter Weight lbs	Approximate Shipping Weight lbs
		ID	A	B		
		inch	inch	inch		
3/8"	F-2204	0.50	32.50	17.96	30.3	45
1/2"	F-2205	0.59	38.00	18.00	30.9	46
3/4"	F-2208	0.82	52.20	18.13	32.8	48
1"	F-2210	1.05	9.84	17.58	14.8	30
1 1/2"	F-2215	1.61	9.84	18.64	21.1	37
2"	F-2220	2.07	9.84	18.96	24.0	40
3"	F-2230	3.07	9.84	20.60	43.9	62
4"	F-2240	4.03	9.84	21.89	61.1	80
6"	F-2260	6.07	9.84	24.64	94.2	160
8"	F-2280	7.98	11.81	27.37	159.2	250

• • • ORDERING INFORMATION

ONICON is committed to providing you with quality products that meet your needs. Our sales engineers will work with you to perform a detailed application review for each order. This review will ensure that we provide the best, most cost effective, product for your application. It will also allow us to avoid any potential applications problems and deliver a product that is ready to use right out of the box.

During the review process we will need to identify and confirm the following information: pipe size, operating pressure (psig), design maximum flow rate (lbs/hr), minimum flow rate (lbs/hr), and system pressure rating (psi).

F-22XX-XS-00

Meter Size

04 - 3/8"	15 - 1.5"	60 - 6"
05 - 1/2"	20 - 2"	80 - 8"
08 - 3/4"	30 - 3"	
10 - 1"	40 - 4"	

Process Connections

M - 300 lb flange
H - 600 lb flange



1500 North Belcher Road, Clearwater, Florida 33765 Tel: 727-447-6140 Fax: 727-442-5699
www.onicon.com E-mail: sales@onicon.com

