

SYSTEM-30 BTU MEASUREMENT SYSTEM Installation and Operation Guide

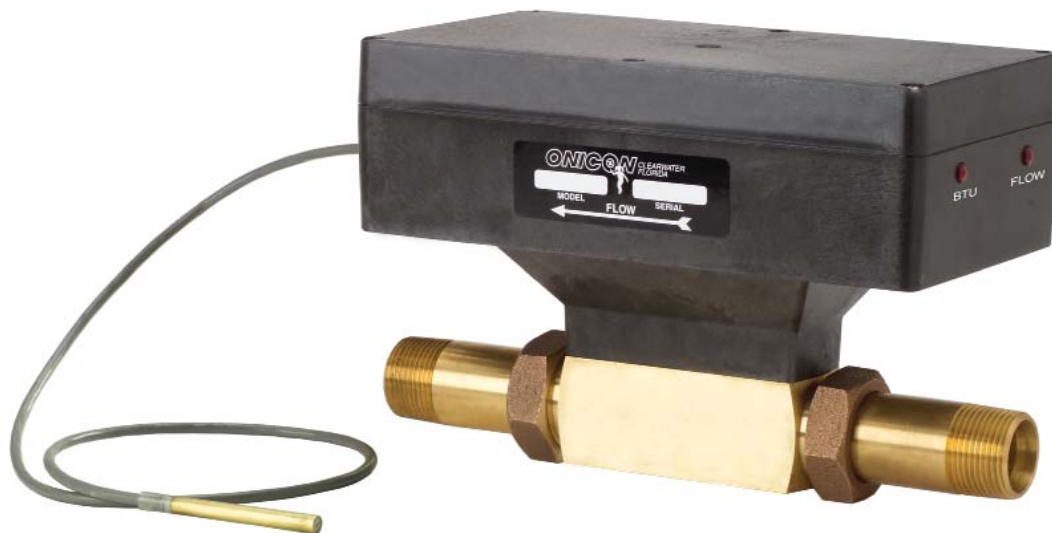

For Software Version 2.8B and Higher

SAFETY INFORMATION

This meter was calibrated at the factory before shipment. To ensure correct use of the meter, please read this manual thoroughly.

Regarding this Manual:

- This manual should be passed on to the end user.
- Before use, read this manual thoroughly to comprehend its contents.
- The contents of this manual may be changed without prior notice.
- All rights reserved. No part of this manual may be reproduced in any form without ONICON's written permission.
- ONICON makes no warranty of any kind with regard to this material, including, but not limited to, implied warranties of merchantability and suitability for a particular purpose.
- All reasonable effort has been made to ensure the accuracy of the contents of this manual. However, if any errors are found, please inform ONICON.
- ONICON assumes no responsibilities for this product except as stated in the warranty.
- If the customer or any third party is harmed by the use of this product, ONICON assumes no responsibility for any such harm owing to any defects in the product which were not predictable, or for any indirect damages.

Safety Precautions:

The following general safety precautions must be observed during all phases of installation, operation, service, and repair of this product. Failure to comply with these precautions or with specific WARNINGS given elsewhere in this manual violates safety standards of design, manufacture, and intended use of the product. ONICON Incorporated assumes no liability for the customer's failure to comply with these requirements. If this product is used in a manner not specified in this manual, the protection provided by this product may be impaired.

The following symbols are used in this manual:



WARNING

Messages identified as "Warning" contain information regarding the personal safety of individuals involved in the installation, operation or service of this product.



CAUTION

Messages identified as "Caution" contain information regarding potential damage to the product or other ancillary products.



IMPORTANT NOTE

Messages identified as "Important Note" contain information critical to the proper operation of the product.

TABLE OF CONTENTS

1.0	INTRODUCTION	3
1.1	PURPOSE OF THIS GUIDE	3
1.2	TYPICAL SYSTEM-30 BTU MEASUREMENT SYSTEM	3
1.3	STANDARD FEATURES AND SPECIFICATIONS.....	4
1.4	WORKING ENVIRONMENT	5
1.5	WARRANTY AND SERIAL NUMBER	5
2.0	UNPACKING	6
2.1	CHECKING THAT YOU HAVE RECEIVED EVERYTHING	6
3.0	INSTALLATION.....	7
3.1	SITE SELECTION	7
3.2	MECHANICAL INSTALLATION	8
3.2.1	Main Unit Installation	8
3.2.2	Thermowell Installation	9
3.2.3	Temperature Sensor Installation	9
3.3	Electrical Installation	12
3.3.1	Single vs. Dual Mode Operation	12
3.3.2	Electrical Wiring.....	15
3.3.3	Isolated Analog Output	16
4.0	DIAGNOSTICS & COMMISSIONING	17
4.1	DIAGNOSTIC LIGHTS	18
4.2	COMMISSIONING.....	19

APPENDIX A – DRAWINGS

A-1	TYPICAL SYSTEM-30 INSTALLATION
A-2 / A-3	THERMOWELL INSTALLATION
A-4	WIRING DIAGRAM
A-5	WIRING DIAGRAM FOR DIN CONNECTOR
A-6	SIGNAL CONNECTION BOARD
A-7	CONDITIONS OF SALE

SECTION 1.0: INTRODUCTION



WARNING

Only qualified service personnel should attempt to install or service this product. Serious injury may result from the improper installation or use of this product.

1.1 PURPOSE OF THIS GUIDE

The purpose of this guide is to provide installation and commissioning procedures and basic operating and servicing instructions for the ONICON SYSTEM-30 BTU MEASUREMENT SYSTEM.

1.2 TYPICAL SYSTEM-30 BTU MEASUREMENT SYSTEM

ONICON'S System-30 is a true heat (BTU) computer, which accepts data from several sensors, performs a series of computations with that data, and transmits the results as an indication of the amount of heat (BTU's) being transferred or as a totalized amount.

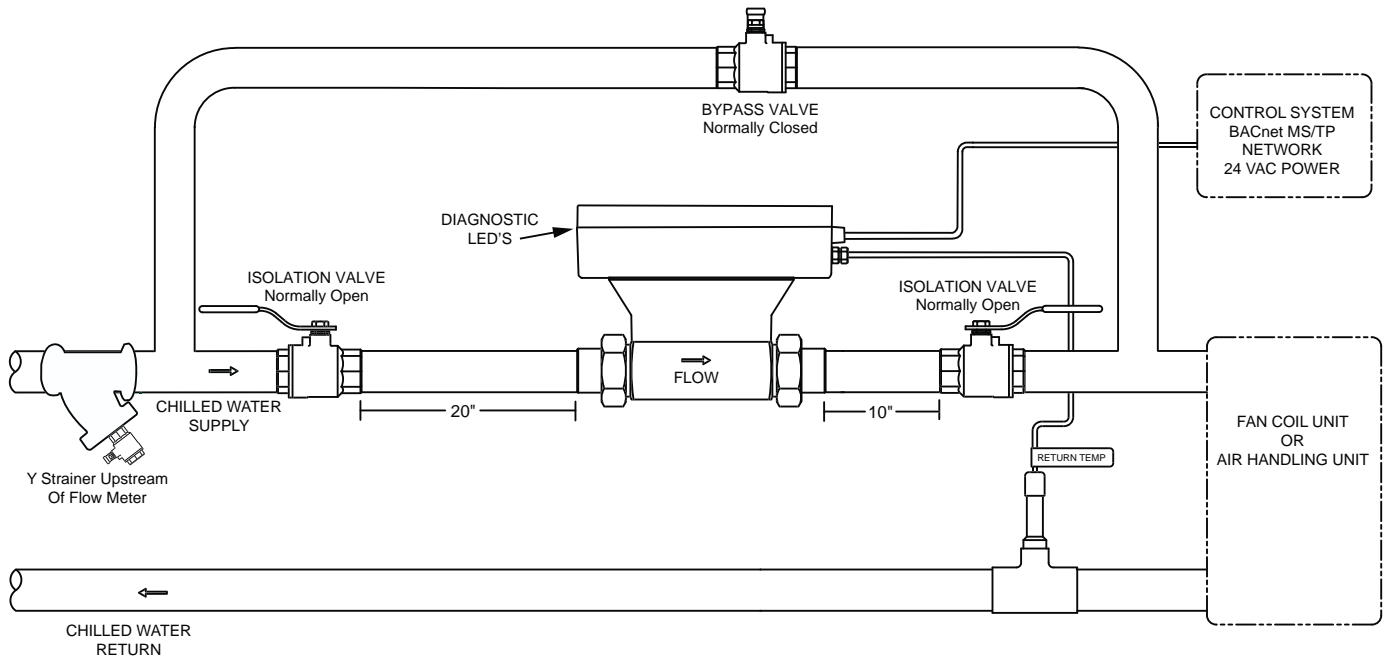

1.3 STANDARD FEATURES AND SPECIFICATIONS

- Single mode BTU calculations, in either the heating or cooling mode, are totalized and reported.
- Two-pipe dual mode BTU calculations in both the heating mode and the cooling mode are totalized and reported separately.

CALIBRATION

Flow sensor and temperature sensors are individually calibrated, followed by a complete system calibration. Field commissioning is also available.

ACCURACY

Differential temperature accuracy $\pm 0.15^\circ$ F over calibrated range
Computing non-linearity within $\pm 0.05\%$
Flow sensor accuracy:
 $\pm 0.5\%$ OF READING at calibrated velocity
 $\pm 1\%$ OF READING from 3 to 30 ft/s (10:1 range)
 $\pm 2\%$ OF READING from 0.4 to 20 ft/s (50:1 range)

TEMPERATURE SENSORS

Solid state sensors are custom calibrated using N.I.S.T. traceable temperature standards.

PROGRAMMING

Factory programmed for each specific application

MEMORY

Nonvolatile EEPROM memory retains all program parameters and totalized values in the event of power loss.

OUTPUT SIGNALS

Isolated solid state dry contacts for mode 1 and mode 2 energy total
Contact rating: 100 mA, 50V
Contact duration: 0.5, 1, 2 or 6 sec selectable

OPTIONAL OUTPUT SIGNALS

One isolated analog output, factory selectable for flow rate, energy rate or delta-T
(Available as 4-20 mA, 0-10 V or 0-5 V signal)
OR
Serial connection for: BACnet MS/TP, MODBUS RTU, JCI N2 - Metasys, Siemens P1 - Apogee, or LONWORKS® networks

OPTIONAL LOCAL DISPLAY:

Alphanumeric LCD displays total energy, total flow, energy rate, flow rate, supply temperature and return temperature
Alpha: 16 characters, 0.2" high
Numeric: 6 digit, 0.4" high

MAINTENANCE:

ONICON recommends periodic inspection and recalibration. No other periodic maintenance is required.

TEMPERATURE RANGE:

Liquid temperature range: 32° F to 200° F
Ambient temperature range: 40° F to 120° F

MECHANICAL

OVERALL DIMENSION:

9.25" L x 5" W x 6.5" H

TEMPERATURE THERMOWELL:

Brass thermowell (1/2" sweat or 1/4" NPT)

ELECTRICAL

This equipment is intended for INSTALLATION CATEGORY (OVERVOLTAGE CATEGORY) II applications

INPUT VOLTAGE: 24 V $\pm 10\%$ AC 50/60 Hz or 24 V ± 4 DC

INPUT CURRENT: 200 mA maximum

TERMINALS CONNECTIONS: Use 18-22 ga. copper wire. Do not exceed 4.5 in-lb (0.5 Nm) of torque when tightening.

WIRING:

CONDUIT: Use PVC jacketed copper cable with a wire gauge suitable for the length of run and required maximum current carrying capacity. The installation must comply with all local, state and federal codes.

PLENUM AREA: (without conduit) Use plenum rated copper cable with a wire gauge suitable for the length of run and required maximum current carrying capacity. The installation must comply with all local, state and federal building codes.

Note: Specifications are subject to change without notice.

1.4 WORKING ENVIRONMENT

The SYSTEM-30 was designed for installation and use in typical commercial and residential environments that are free of corrosive liquids and fumes, direct liquid exposure, heavy condensation, and temperature extremes and vibrations.

The operating ambient air temperature range is 40° F to 120° F.

The electrical power should be relatively clean, free of high frequency noise, large voltage transients, and protected from power surges and brown outs.

1.5 WARRANTY & SERIAL NUMBER

Warranty

ONICON's 2-year "No-fault" warranty reduces start-up costs with extended coverage that includes coverage for incidental damage during installation. Certain exclusions apply. See our complete warranty statement for details.

Serial Number

The serial number of your SYSTEM-30 is located on the side of the enclosure. Serial numbers are unique identifiers that you should have available when contacting the factory for assistance regarding your system.

SECTION 2.0: UNPACKING

The SYSTEM-30 generally ships in one package unless optional hardware or equipment is ordered. If any items are damaged, notify the shipping company (all products are shipped insured) and ONICON.

2.1 CHECKING THAT YOU HAVE RECEIVED EVERYTHING

- **Standard Documentation**

Enclosed with each SYSTEM-30 is a comprehensive documentation package that includes the following items:

The SYSTEM-30 BTU MEASUREMENT SYSTEM Installation and Operation Guide
The System-30 Calibration Data Sheet
Typical Installation Drawing
Wiring Diagram

Please notify ONICON immediately if any items are missing.

- **The Main Unit**

Remove the System-30 from the shipping carton and inspect it for physical damage.

- **Temperature Sensors**

One temperature sensor is built into the body of the meter and the other is connected to the main unit via a permanently attached cable. Inspect the free sensor and cable for external damage.

- **Temperature Thermowell**

A standard thermowell with installation hardware is packed with the main unit.

- **Mounting Hardware**

The System-30 is supplied with two tail pieces to facilitate connection to the piping system. A compression fitting with retaining nut makes up one end of each tail piece. The other end will either be a sweat fitting for copper or a threaded nipple with NPT threads.

SECTION 3.0: INSTALLATION

The SYSTEM-30 BTU MEASUREMENT SYSTEM should be installed by experienced plumbers and others with related knowledge and experience in the heating, cooling, and fluid metering fields. ONICON will be happy to assist with technical recommendations and to provide guidance by telephone and/or email. On-site field engineering, installation, and/or service is also available at an additional cost.

The installer should use good trade practices and adhere to all state and local building or other applicable codes.



CAUTION

ONICON strongly recommends the use of a valved bypass and strainer in conjunction with the installation of the System-30 to facilitate servicing and to protect the turbine assembly during start-up.

3.1 SITE SELECTION

Careful attention to the site selection for the system components will help the installers with the initial installation, reduce start-up problems, and make future maintenance easier. For example, do not install the System-30 or its temperature sensor where it will be difficult for personnel to perform periodic maintenance and calibration. When selecting a site for mounting the system components, consider the criteria under Section 1.4, WORKING ENVIRONMENT, as well as the following:

The Main Unit

Choose the location (supply or return) with the longest straight, unobstructed run. Ideally, the location chosen should allow for at least 20 diameters of unobstructed straight run upstream of the meter and at least 10 diameters of unobstructed straight run downstream. If both the supply and return have adequate straight run conditions, locate the meter in the supply.

The location must be accessible to facilitate service and recalibration.

The Temperature Sensor

The temperature sensor should be located in an accessible location. This will facilitate any on-site service.

Place the temperature sensor away from sources of electrical noise that might interfere with the temperature sensor signal.

3.2 MECHANICAL INSTALLATION

3.2.1 Main Unit Installation

TYPICAL SYSTEM-30 INSTALLATION

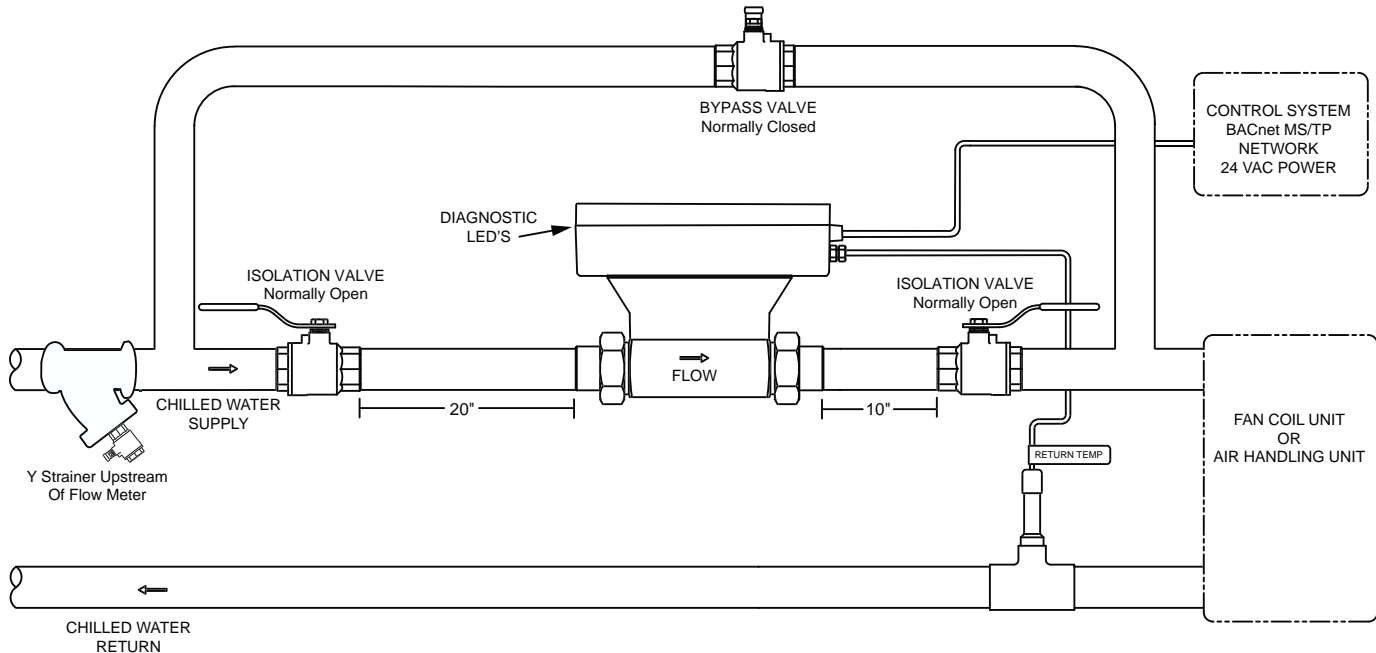

Find an easily accessible location where wire connections can be made and the diagnostic LED's can be viewed from floor level. The location where the main unit is mounted should be free from vibration. Clean the external surface of the pipe at the installation site so that it is free of debris, foreign matter, solids, leak inhibitors, and chemically aggressive substances. Next, locate the tail pieces that were shipped with the main unit and install these on the pipe making certain that the compression nuts are correctly oriented. Wherever appropriate, use pipe dope on threaded connections to ensure a leak free seal. **DO NOT USE TEFLON TAPE.**

Insert the main unit between the two open ends of the pipe and secure in place using the compression fittings. **MAKE CERTAIN THAT THE FLOW DIRECTION ARROW ON THE BODY OF THE MAIN UNIT IS POINTING IN THE DIRECTION OF FLOW.**

CAUTION



Before you attempt to use the BTU measurement system, isolate the main unit, open the bypass and flush the entire system so that it is free of flux, solder, pipe and tube cuttings and any other free moving particles.

3.2.2 Thermowell Installation



IMPORTANT NOTE

It is important that no dirt or other foreign material be allowed into the thermowell as this could affect the thermal response of the system.

Standard Thermowell

The most common installation methods are shown below. Consult ONICON for special applications.

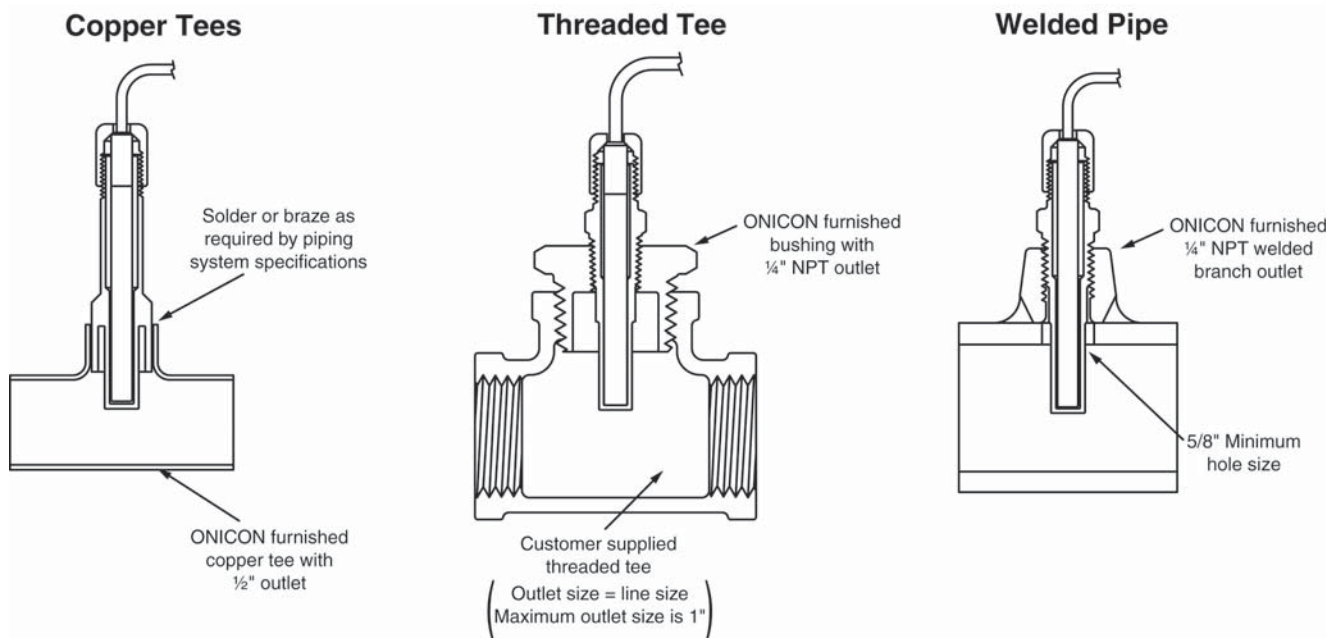

3.2.3 Temperature Sensor Installation

The temperature sensor is factory matched and permanently attached to the BTU measurement system. Sensors from different BTU meters cannot be used without being returned to the factory for recalibration.

Apply a thin coat of thermal compound to the temperature sensor, and gently insert the temperature sensor all the way into the thermowell until it contacts the bottom of the cavity. Gently tighten the retainer cap. **DO NOT OVERTIGHTEN.** The thermowell completely seals the plumbing system without the retainer cap. The only purpose of the cap is to keep the sensor from losing contact with the bottom of the thermowell cavity.



IMPORTANT NOTE

Cable length is specified at time of order. This is three wire shielded plenum rated cable. Altering the cable length may affect calibration. Do not change the cable length without consulting ONICON.

THERMOWELL INSTALLATION IN THREADED PIPE TEES THERMOWELL

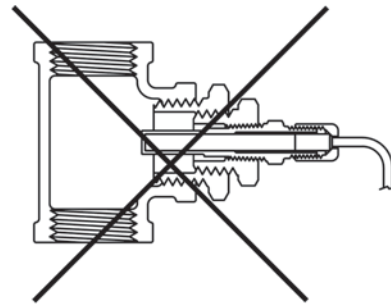
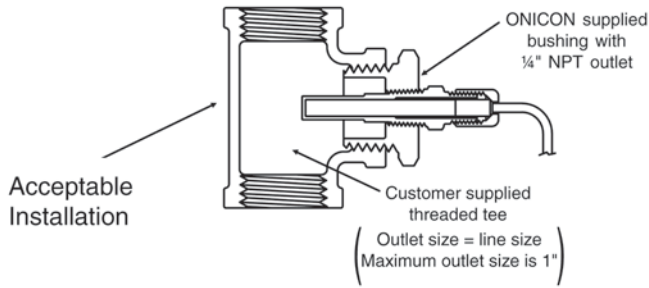

DO NOT INSTALL MORE THAN ONE BUSHING.
Use no more than one bushing, or the temperature data will not be correct!

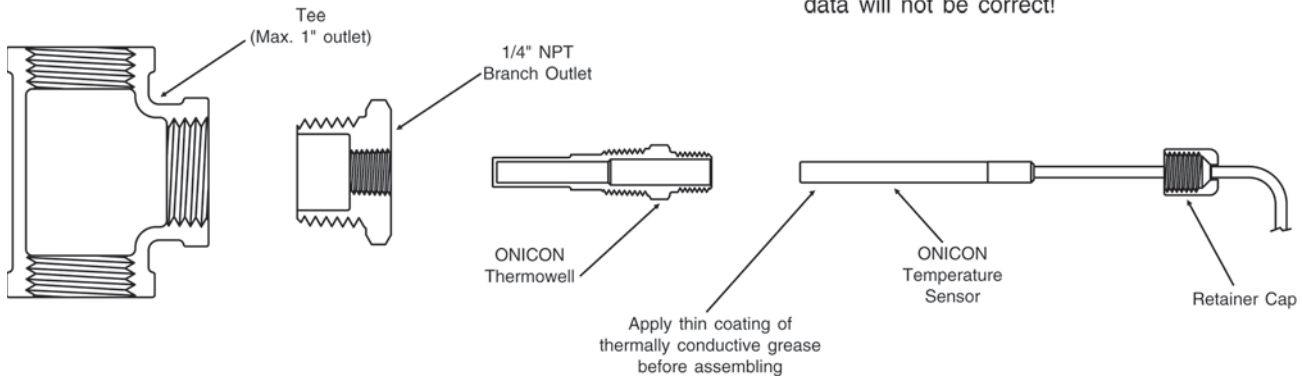

THERMOWELL INSTALLATION IN COPPER TEE

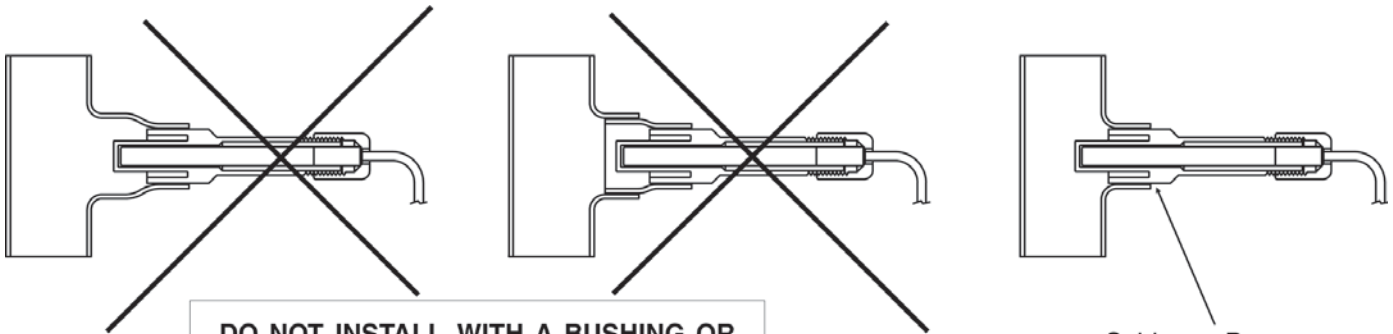

DO NOT INSTALL WITH A BUSHING OR TEE WITH EXTENDED BRANCH OUTLET.
Install thermowell directly into the ONICON furnished tee only or the temperature data will not be correct!

Solder or Braze as required by piping system specifications

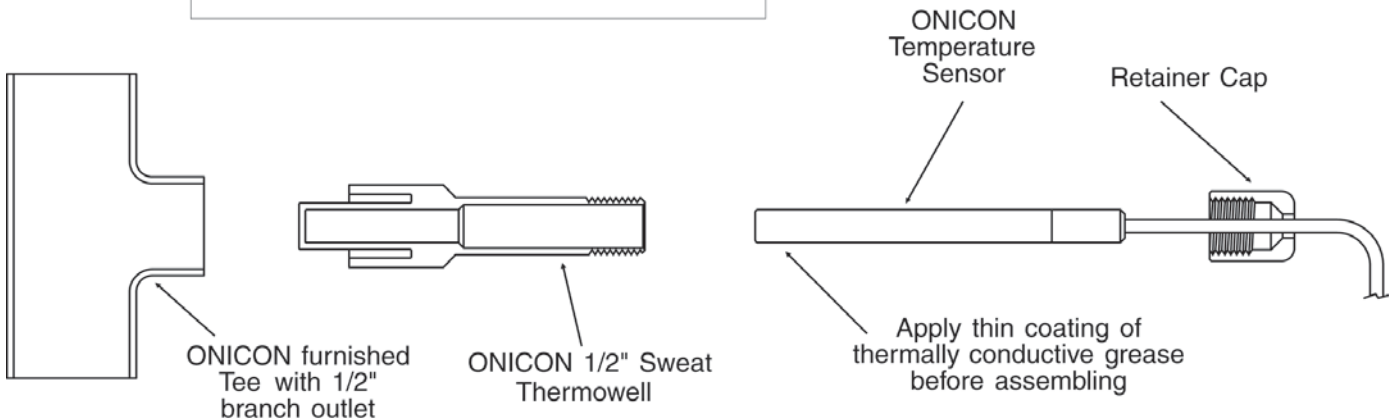

THERMOWELL INSTALLATION IN WELDED PIPE

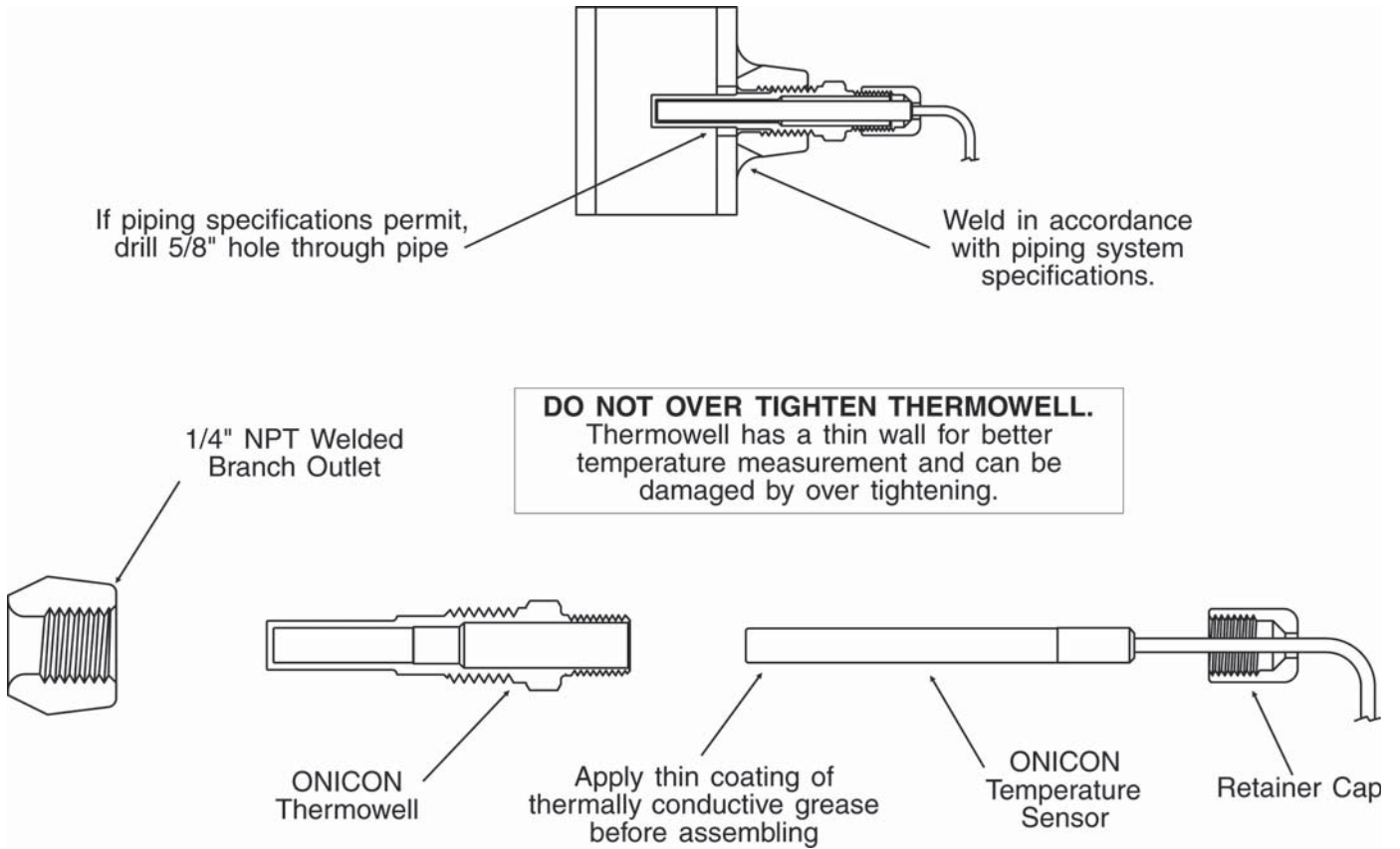

3.3 ELECTRICAL INSTALLATION

All user supplied conduit fittings, junction boxes, etc. are to be installed as required by legal codes.

IMPORTANT NOTE



The System-30 BTU Measurement System is designed with one internal (Temp 1) and one remote (Temp 2) temperature sensor. If the meter body is located in the supply pipe, then the internal temperature sensor will indicate the supply temperature, and the remote sensor will indicate the return temperature. This relationship will reverse if the meter body is located in the return pipe. The location of the meter will also affect the logic used to determine mode 1 and mode 2 operations for dual mode applications. Single mode energy measurements are absolute measurements and are not effected by polarity of the Delta t.

3.3.1 Single Mode (4 Pipe) Vs. Dual Mode (2 Pipe) Operation

ONICON System-30 BTU Meters may be configured for single or dual mode applications. Single and dual mode is a reference to the piping system and not the meter itself. Single mode (4 pipes) applications are those that always have the same relationship between the supply and return pipe temperatures. In dual mode (2 pipes) applications the polarity of the temperature differential (delta-T) reverses, often on a seasonal basis.

It is often desirable to totalize the amount of energy transferred in each mode in separate registers. For these applications, ONICON Btu meters may be configured for dual mode operation. In this configuration, the meter will measure and totalize energy in separate registers based on the polarity of the delta-T.

The drawings and tables on the next pages illustrate the relationship between meter location, temperature sensor and mode of operation.

Temperature Sensor/ Mode of Operation Relationship with Meter in Supply Line

Supply Temp	Temperature 1 Sensor (Internal Sensor)
Return Temp	Temperature 2 Sensor (External Sensor)
Mode 1 Total	Heating (Supply Temp > Return Temp)
Mode 2 Total	Cooling (Supply Temp < Return Temp)

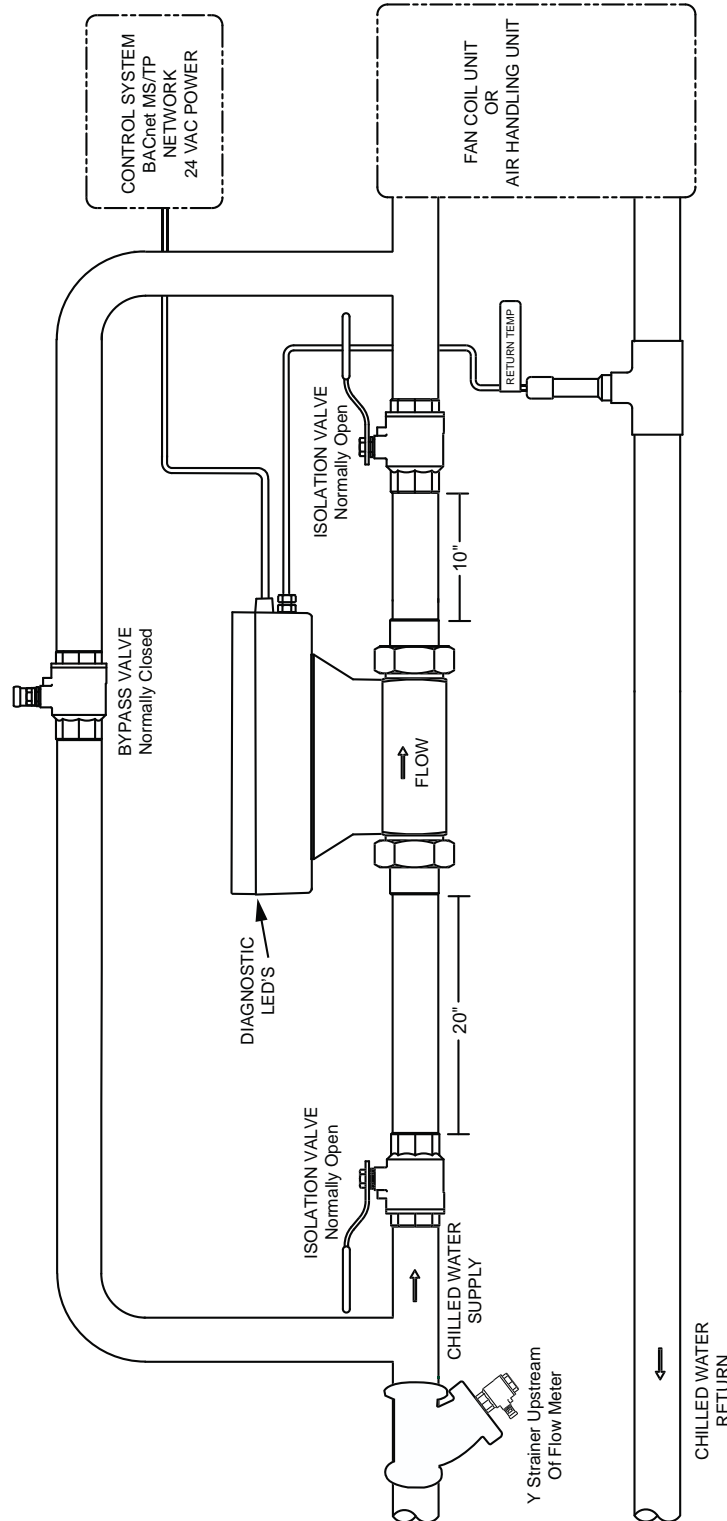

Temperature Sensor/ Mode of Operation Relationship with Meter in Return Line

Supply Temp	Temperature 2 (External Sensor)
Return Temp	Temperature 1 (Internal Sensor)
Mode 1 Total	Cooling (Supply Temp < Return Temp)
Mode 2 Total	Heating (Supply Temp > Return Temp)

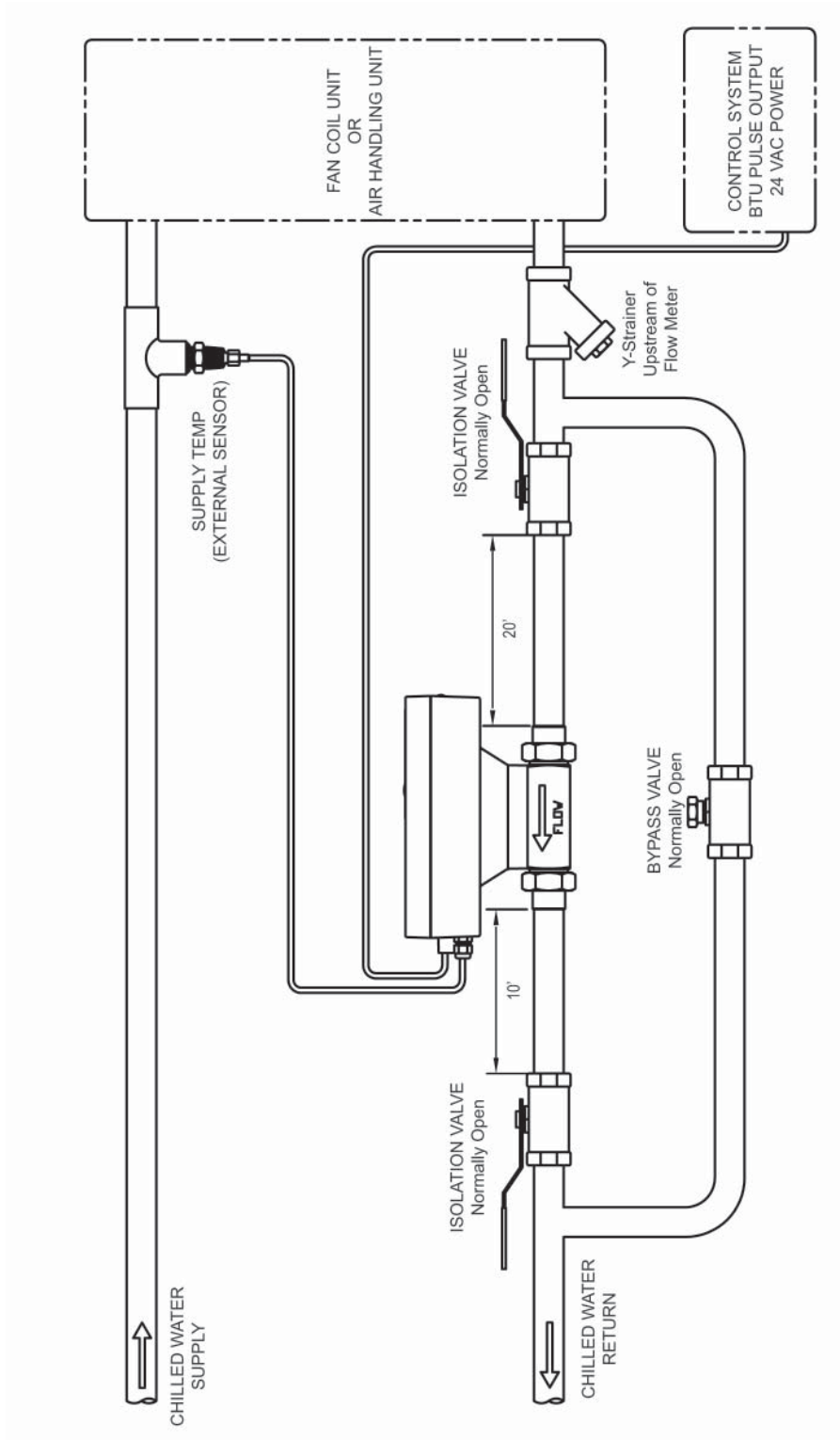

3.3.2 Electrical Wiring

Connect all BTU meter signal outputs to terminal strip T1 and/or T4 (optional communication output) as shown below.

Then connect the 24 V AC/DC input power to terminal strip T1. The standard SYSTEM-30 is configured for 24 V AC 60 Hz operation or 24 V DC operation. Do not connect the 24 V AC/DC source until all other signal connections have been made and verified.

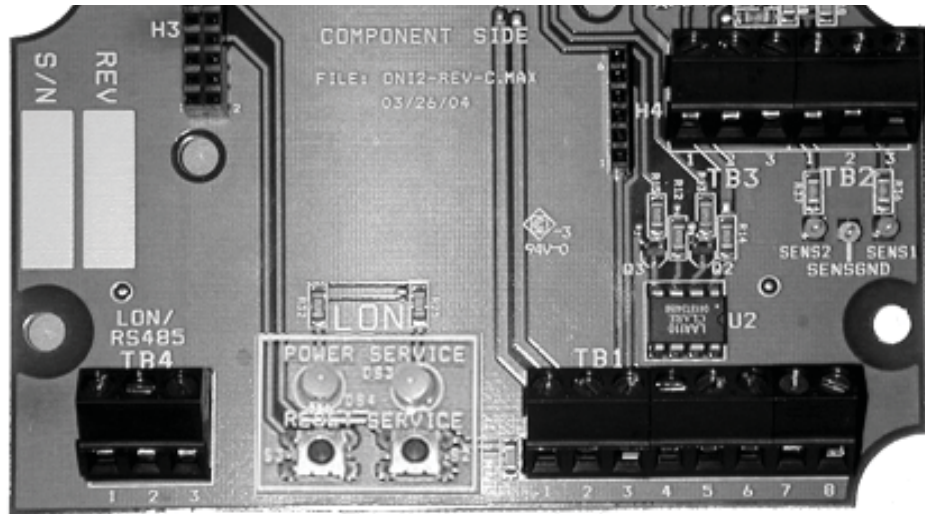

View of Signal Connection Board

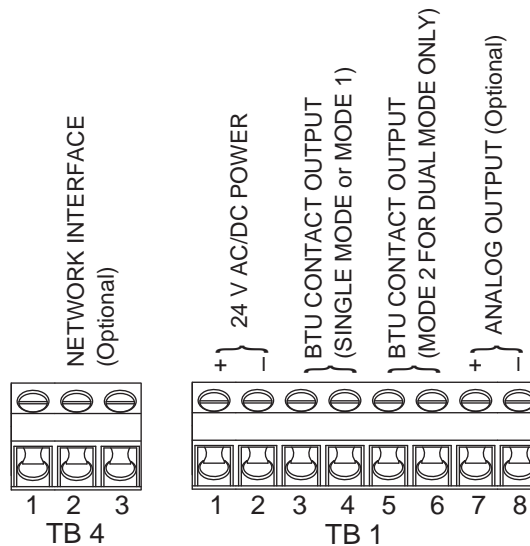

3.3.3 Isolated Analog Output (Optional):

The System-30 may be ordered from the factory with an optional analog output. This output is factory configured to provide a linear output proportional to any one of the following operating parameters: flow rate, energy rate, internal temperature sensor, external temperature sensor or delta temperature. The format of this output may be selected to provide a 4-20 mA, 0-10 Volt or 0-5 Volt signal.

This selection is field configurable using the jumpers located on the analog output board as shown below. Changing any of the displayed units or multipliers will affect the analog output. If any unit or multiplier values are changed at the System-30 BTU Meter, the analog output value will also be changed. If you are unsure of the ramifications of any changes you are contemplating, please contact ONICON for assistance.

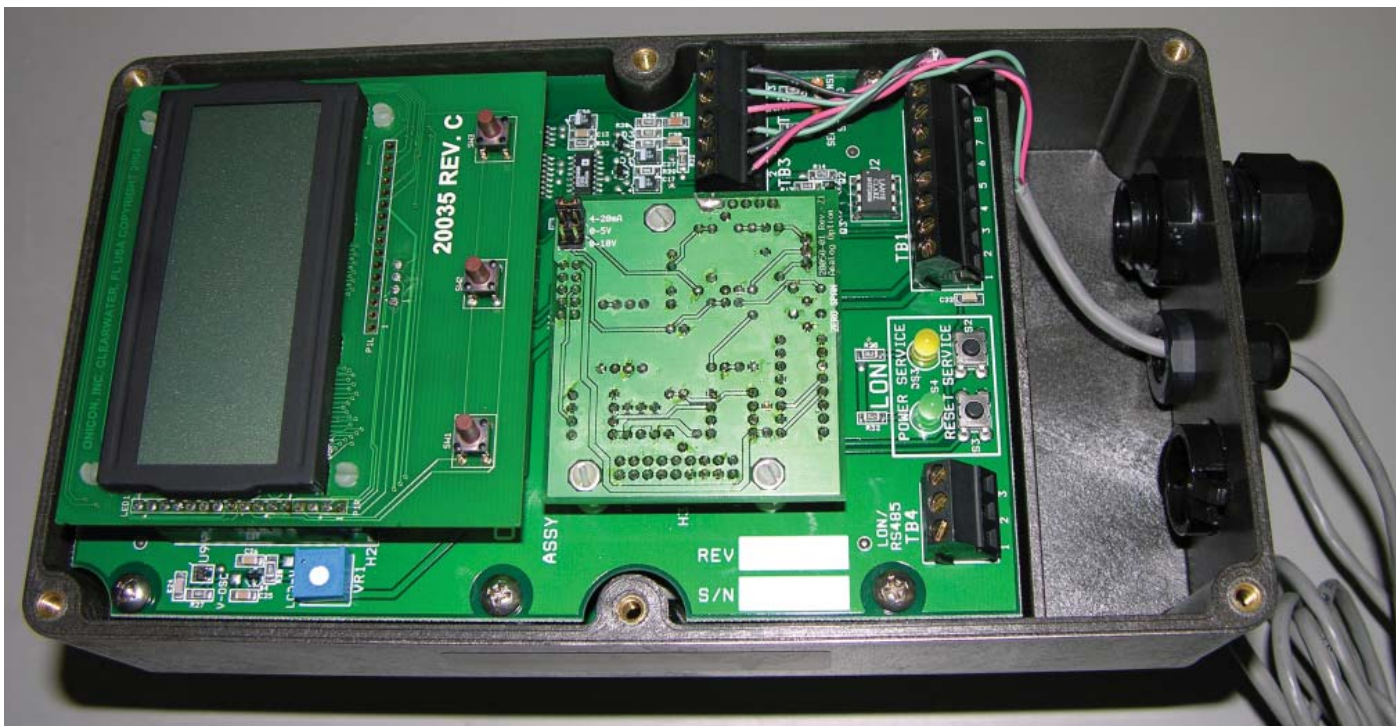
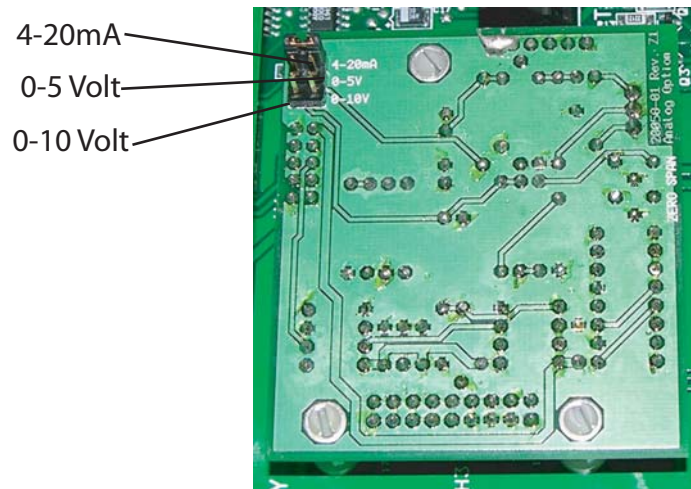

SECTION 4.0: DIAGNOSTICS AND COMMISSIONING

4.1 DIAGNOSTICS

The ONICON System-30 BTU MEASUREMENT SYSTEM uses a microprocessor to calculate energy. Factory programmed settings provide energy total outputs in accordance with the customer's application data. An optional isolated analog output for energy rate, flow rate or delta-T may also be available. Refer to the BTU meter calibration sheet for a complete listing of factory settings. These settings cannot be changed in the field. Contact ONICON if changes to the calibration are required.

The System-30 is equipped with diagnostic indicator lights that confirm the operation of the microprocessor and its input circuitry.

Please contact ONICON if either of the diagnostic lights indicate a potential problem with the operation of the BTU measurement system.

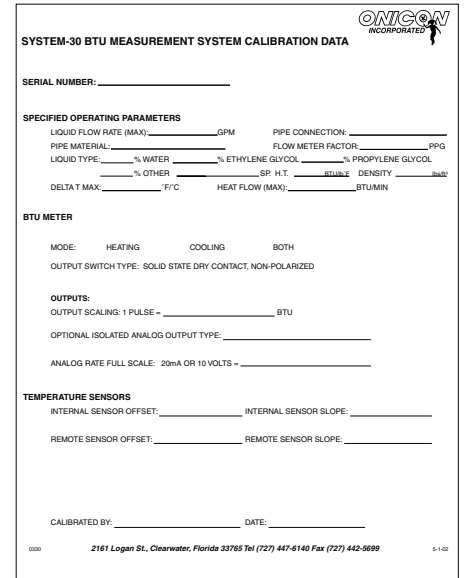

The form is titled "SYSTEM-30 BTU MEASUREMENT SYSTEM CALIBRATION DATA" and features the ONICON logo in the top right corner. It contains several sections for data entry: "SERIAL NUMBER:" with a blank line; "SPECIFIED OPERATING PARAMETERS" including fields for "LIQUID FLOW RATE (MAX):", "PIPE CONNECTION:", "PIPE MATERIAL:", "FLOW METER FACTOR:", "LIQUID TYPE:" (with sub-fields for % WATER, % ETHYLENE GLYCOL, % PROPYLENE GLYCOL, and % OTHER), "SP. HT.", "DENSITY", "DELTA T MAX:", and "HEAT FLOW (MAX):"; "BTU METER" section with "MODE:" (HEATING, COOLING, BOTH), "OUTPUT SWITCH TYPE:", "OUTPUTS:", "OUTPUT SCALING:", "OPTIONAL ISOLATED ANALOG OUTPUT TYPE:", and "ANALOG RATE FULL SCALE:"; "TEMPERATURE SENSORS" section with "INTERNAL SENSOR OFFSET:", "INTERNAL SENSOR SLOPE:", "REMOTE SENSOR OFFSET:", and "REMOTE SENSOR SLOPE:"; and "CALIBRATED BY:" and "DATE:" fields. At the bottom, it includes the address "2161 Logan St., Clearwater, Florida 33765", phone and fax numbers, and a small page number "5-1-02".

4.1.1 Diagnostic Lights

Energy

Located on the end of main unit opposite the cable connection is a red LED labeled BTU. This LED will flash as energy is transferred.

Liquid Flow

Located on the end of main unit opposite the cable connection is a red LED labeled FLOW. This LED will flash at a rate that is proportional to the liquid flow rate. An unlit LED indicates no flow signal.

4.2 COMMISSIONING

Please read all installation instructions carefully before proceeding. Wiring diagrams are located in the appendix. A worksheet for checking off these steps and recording measured values is located on the following page.

1.	Confirm main unit location and adequate straight pipe run to achieve desired results.	<p>Is the main unit located in the correct location as required by the plans?</p> <p>Compare actual straight pipe upstream and downstream of the main unit location to the recommended distances identified in this manual. Note: This manual is very conservative and assumes the worst-case pipe obstructions. Contact ONICON to discuss specifics of your application.</p>
<p>In order to proceed with the following steps, the System-30 must be operating and connected to the control system. There must also be flow in pipes. Flow signal readings should be taken while holding the flow rate constant if possible; otherwise, take the various output readings as quickly as possible.</p>		
2.	Confirm correct supply voltage.	<p>Verify that the correct supply voltage is available at the System-30 signal cable connections. The System-30 BTU MEASUREMENT SYSTEM operates from 24 VAC \pm 4 volts.</p>
3.	With the HVAC system active, verify that the diagnostic LED's for FLOW and BTU are both flashing.	<p>The LED's are located on the exterior of the main unit on the end opposite from the cables.</p>
<p>The following steps require a multi-meter with the ability to measure DC voltage as well as DC frequency in hertz. Remove the six screws that secure the cover to the main unit and carefully lift the cover off.</p>		
4.	Check temperature readings for T1, T2 and the differential temperature.	<p>Set multi-meter for 2 to 4 volt range.</p> <p>T1: Measure DC volts between terminals 2(+) and 3(-). T2: Measure DC volts between terminals 2(+) and 3(-). Delta T: Measure DC volts between terminals 2 and 2.</p> <p>The relationship between voltage and temperature is 10 mV/degree F. Multiply the reading in volts by 100 to obtain degrees F. Compare the calculated temperatures to expected values.</p>
5.	Check flow signal.	<p>Set multi-meter for DC hertz, voltage range > 15 volts. The test points for flow are located next to the reset button.</p> <p>GPM = Frequency in Hz X 60 Meter Factor in ppg (refer to calibration tag for meter factor)</p> <p>Compare the calculated flow rate to expected values.</p>
6.	Check Energy Total Output (BTU Output Mode 1 and/or Mode 2).	<p>Set multi-meter for DC volts, voltage range > 15 volts.</p> <p>Mode 1: Measure DC volts between terminals 3 and 4 Mode 2: Measure DC volts between terminals 5 and 6</p> <p>Confirm that the voltage changes state (low to high or high to low) each time the controls system register records a new energy total.</p>
<p>End of standard commissioning. Please contact ONICON at (727)447-6140 with any questions.</p>		

COMMISSIONING WORKSHEET - ONICON BTU METERS

Please read all installation instructions carefully prior to proceeding with these steps. Wiring diagrams are located in the appendix. Use the following worksheet for checking off the commissioning steps and recording measured values:

Step	Test/Measurement	S/N:	S/N:	S/N:	S/N:
1.	Meter location				
2.	Supply voltage verified				
3.	Verify diagnostic LED's are flashing.				
4.	Note and record temperature readings for T1, T2 and delta-T.				
5.	Note and record flow rate.				
6.	Confirm contact closure output operation for Mode 1 & Mode 2.				

TROUBLESHOOTING GUIDE FOR ONICON SYSTEM-30 BTU MEASUREMENT SYSTEMS

NOTE: Also refer to the COMMISSIONING GUIDE located on the preceding page.

Reported Problem	Possible Solutions
No flow signal/ energy signal (While hydronic system is active)	<ul style="list-style-type: none"> • Verify 24 VAC supply voltage to the System-30. • Verify correct wiring to the System-30 (see wiring diagram). • Check turbine for clogging due to debris. • If none of the above, double check hydronic system to ensure that flow is really present in the line. • NOTE: Flow meter function cannot be verified by blowing on the turbine. The sensing system requires a conductive liquid to operate.
Displayed flow rate too high or too low	<ul style="list-style-type: none"> • Verify that System-30 isolation valves are fully open and bypass valve is fully closed (if bypass is used). • Check turbine(s) for debris. • Verify supply voltages.
Displayed temperature(s) too high or too low vs. expected values	<ul style="list-style-type: none"> • Verify that thermowell is inserted into the flow stream and that the temperature sensor is completely inserted into the thermowell.
Data not available at the control system	<ul style="list-style-type: none"> • Verify that the wiring to the building control system is correct.
For technical assistance, contact ONICON at (727) 447-6140.	

APPENDIX A – DRAWINGS

- A-1 TYPICAL SYSTEM-30 INSTALLATION

- A-2 / A-3 THERMOWELL INSTALLATION

- A-4 WIRING DIAGRAM

- A-5 SIGNAL CONNECTION BOARD

- A-6 WIRING DIAGRAM FOR DIN CONNECTOR

- A-7 CONDITIONS OF SALE

SYSTEM-30 BTU MEASUREMENT SYSTEM WITH INTEGRAL FLOW METER & TEMPERATURE SENSORS

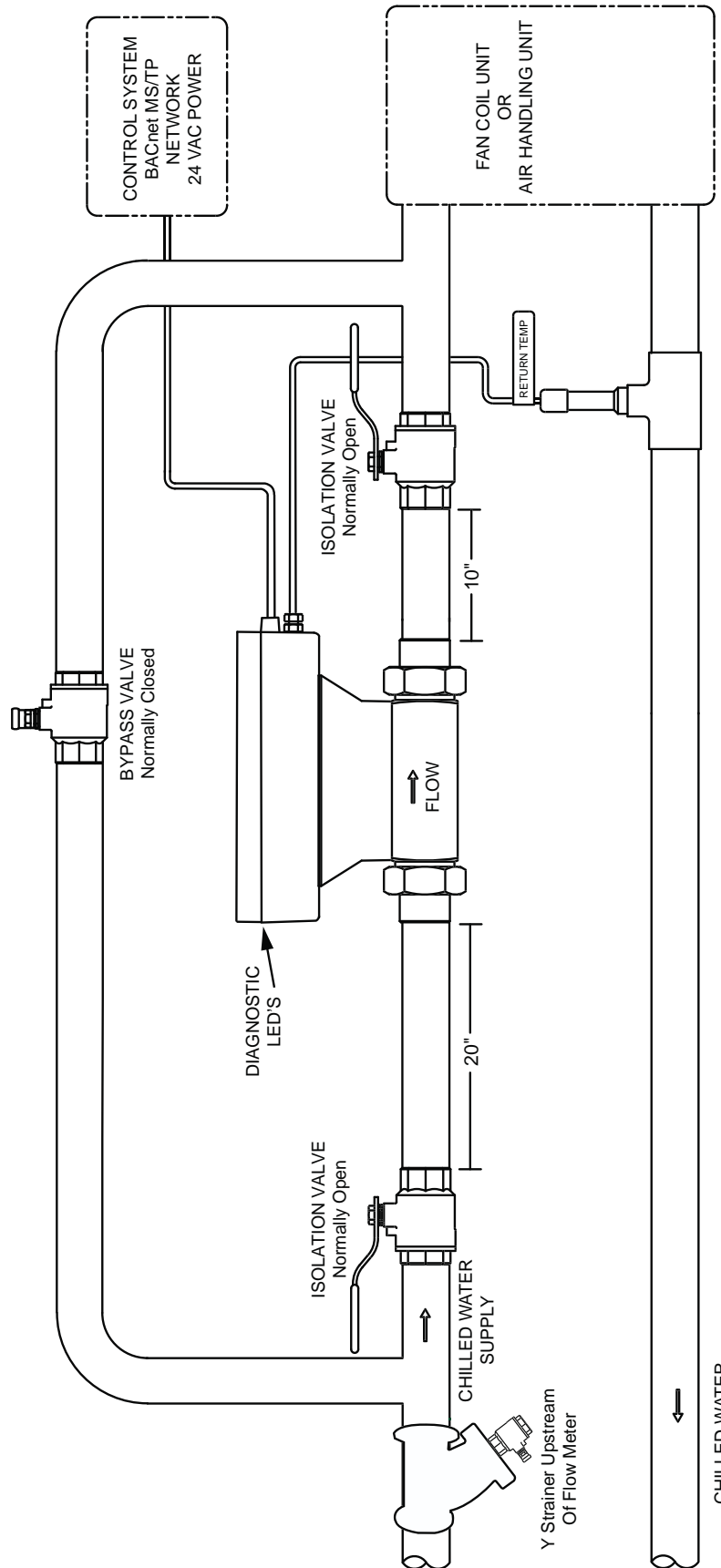

THERMOWELL INSTALLATION In Welded Pipe

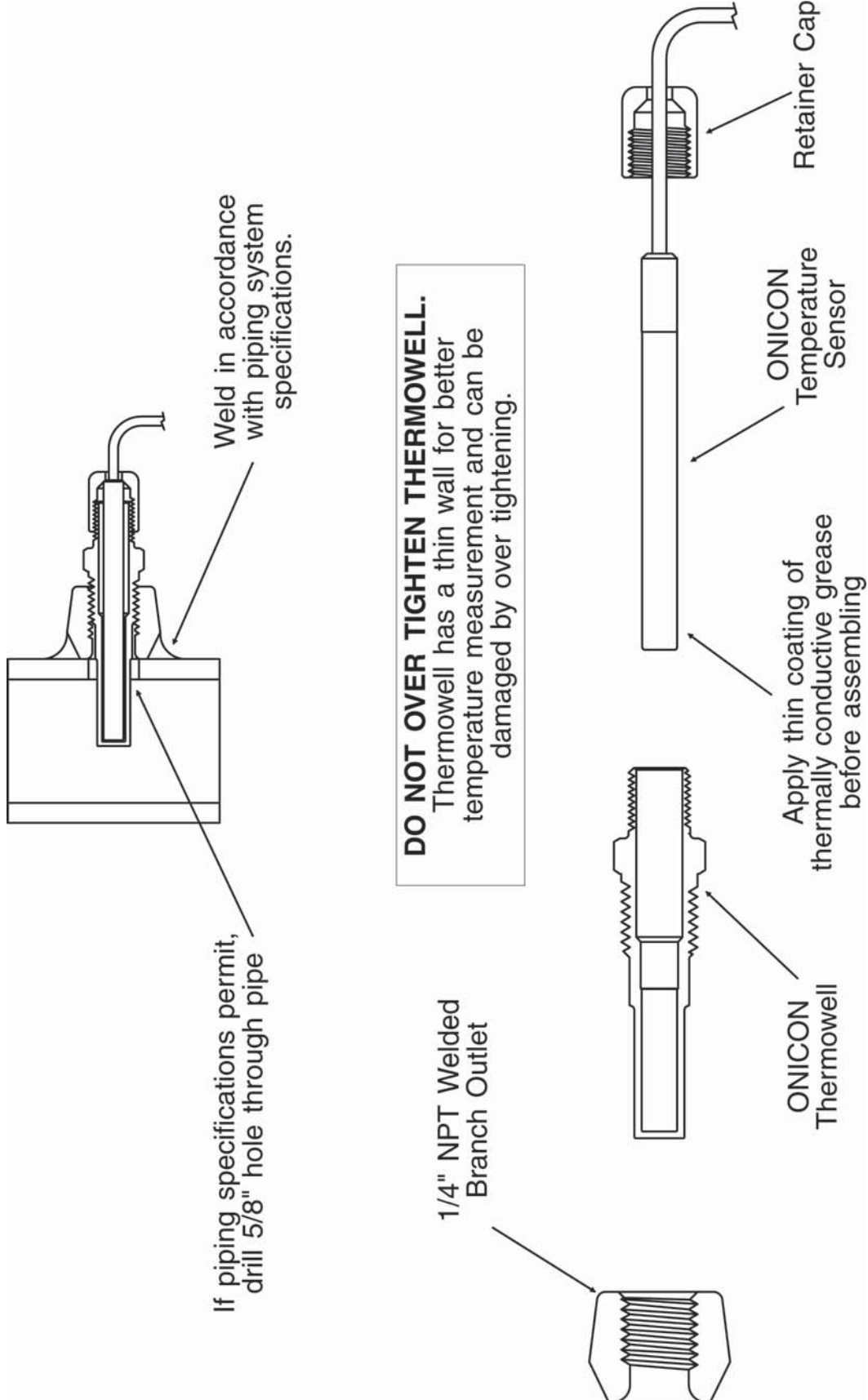

ALTERNATE THERMOWELL INSTALLATION In Copper Tees

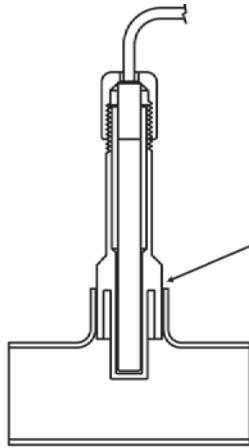

Solder or Braze as required by piping system specifications

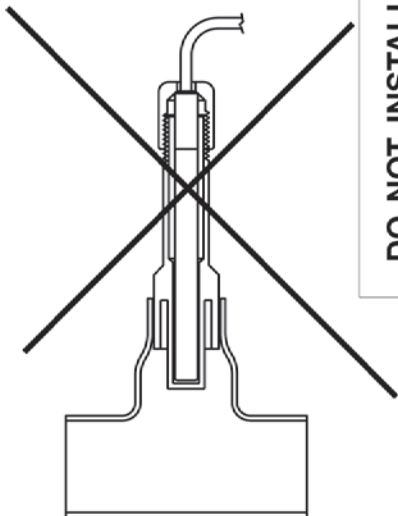
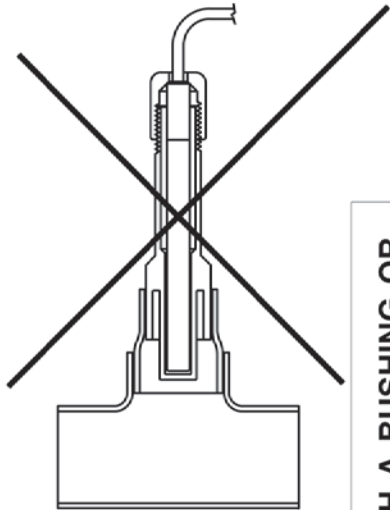

DO NOT INSTALL WITH A BUSHING OR TEE WITH EXTENDED BRANCH OUTLET.
Install thermowell directly into the ONICON furnished tee only or the temperature data will not be correct!

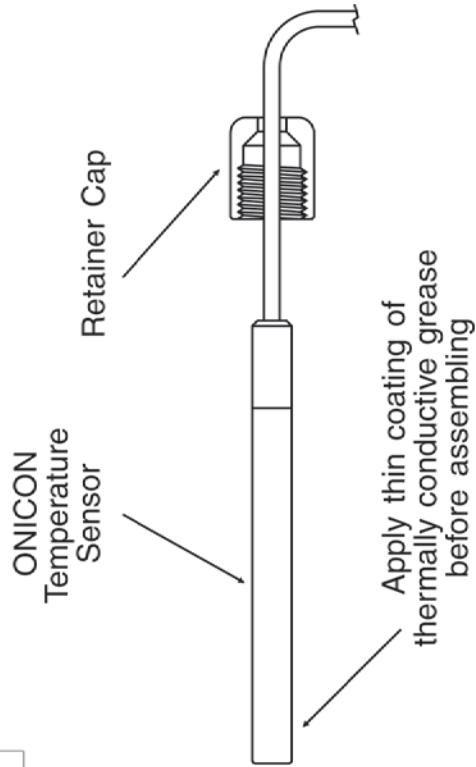

ONICON furnished Tee with 1/2" branch outlet

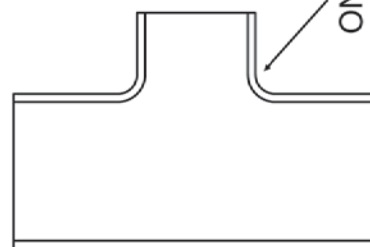

SYSTEM-30 WIRING DIAGRAM

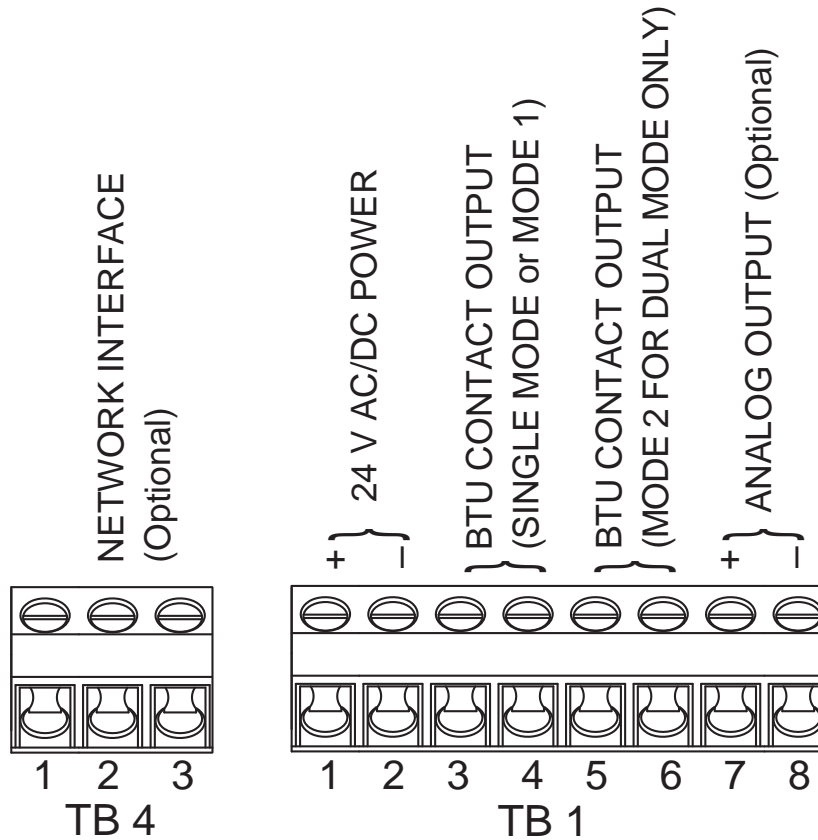

SYSTEM-30 SIGNAL CONNECTION BOARD

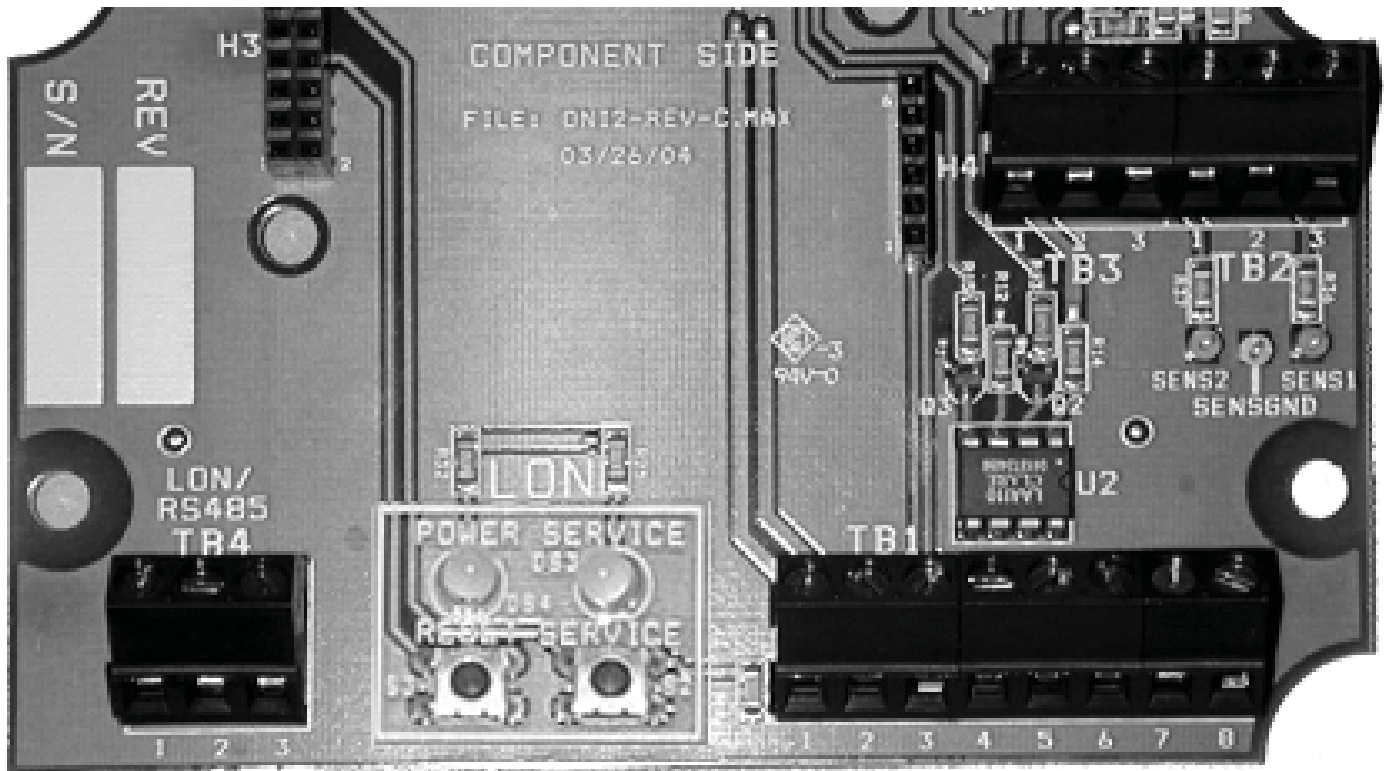

SYSTEM-30 WIRING DIAGRAM For DIN Connector

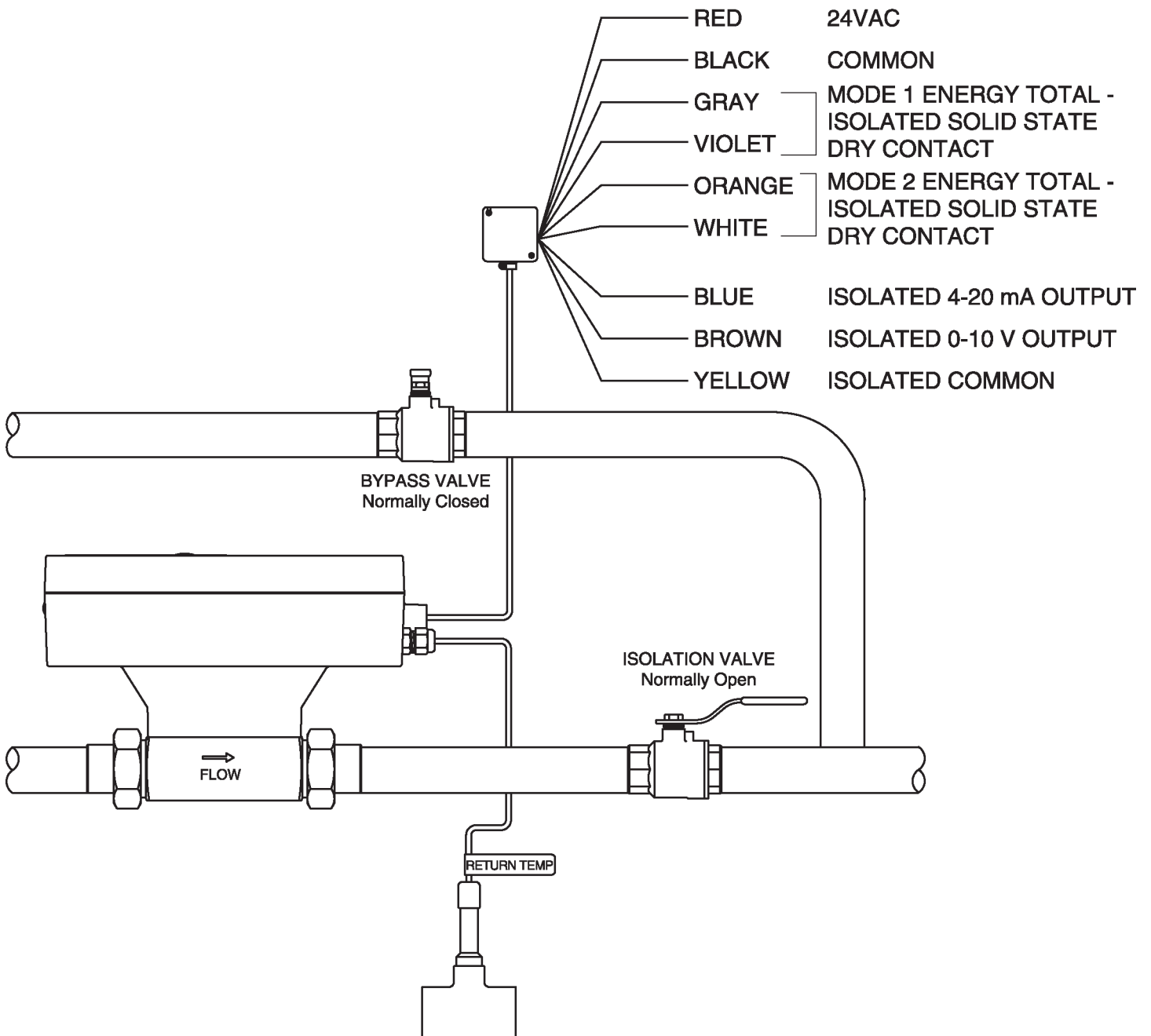

CONDITIONS OF SALE

1. **ACCEPTANCE:** The following Conditions of Sale apply to all sales of ONICON's products. These provisions shall apply even if ONICON fails to object to provisions appearing on, incorporated by, referenced in, or attached to Buyer's purchase order form. Buyer's acceptance of delivery of ONICON's products constitutes its acceptance of these Conditions of Sale.
2. **DELIVERY AND TITLE:** All product shipments are F.O.B. shipping point and title passes to the Buyer at the time ONICON delivers the merchandise to the carrier. Risk of loss or damage to the product passes to the Buyer at the time ONICON delivers the product to the carrier. The Buyer immediately upon receipt should inspect all shipments, and should there be any evidence of damage or loss in transit, Buyer must file claims or tracers upon carrier. ONICON will assist in tracing shipments upon request.
3. **LIMITED WARRANTY:** ONICON warrants that for a period of two (2) years following the date of original shipment of an ONICON product: (i) the product will conform to ONICON's standard written specifications applicable to such product in effect on the date of Buyer's order, or as modified by ONICON's quotation or Buyer's purchase order accepted by ONICON, (ii) the product will be free from defects in workmanship, and (iii) that ONICON has title to the product prior to shipment to the Buyer; provided, however, that the warranties provided herein shall be void and may not apply in the event Buyer misuses or damages a product, including, but not limited to, any use by the Buyer of a product for an application other than one of a type approved by ONICON. ONICON's sole liability and Buyer's sole remedy for any breach of the foregoing warranty is for ONICON to repair or replace, at ONICON's option, any defective product that is returned to ONICON during the warranty period. EXCEPT AS MAY BE SPECIFICALLY AGREED BY ONICON IN WRITING IN RELATION TO EACH SALE, NO OTHER WARRANTIES SHALL APPLY, WHETHER EXPRESSED, IMPLIED OR STATUTORY, AND THERE SHALL BE NO IMPLIED WARRANTIES OF MERCHANTABILITY AND FITNESS FOR A PARTICULAR PURPOSE.
4. **REMEDIES:** ONICON's OBLIGATION UNDER THE FOREGOING WARRANTIES IS LIMITED SOLELY TO REPAIR OR REPLACEMENT, AT ONICON'S OPTION, OF DEFECTIVE OR NONCONFORMING PRODUCTS. ONICON SHALL NOT BE LIABLE FOR CONSEQUENTIAL, INDIRECT, PUNITIVE, INCIDENTAL, OR SPECIAL DAMAGES WHETHER FOUND ON CONTRACT, TORT OR ANY OTHER THEORY OF LAW. No products shall be returned to ONICON without its prior consent and transportation and insurance costs shall be prepaid. Any repair or replacement of ONICON's products under the foregoing warranty will be at no charge to the Buyer provided such repair is done at the ONICON factory or authorized service center. ONICON products that are repaired or replaced under this warranty will be returned to Buyer via the same method of shipment use to return the product to ONICON. Repair or replacement of ONICON products is conditioned upon ONICON's acknowledgement of any alleged defect or nonconformance during the warranty period and issuance of a Return Authorization number. All product returns must reference the Return Authorization number on the outside of the shipping carton and on any paperwork referencing the return.
5. **PRICES AND PAYMENT TERMS:** The prices set forth in the most recent quote or acknowledgement as applicable, supersede all previous prices or quotations. All quotations are subject to change or withdrawal without notice except as may be specifically noted on the face of the quotation. The prices shown do not include sales, excise or government charges payable by ONICON to Federal, State, or local authority. Any such tax or charge now or hereafter imposed upon the sale or shipment of the products under this contract will be added to the purchase price. Buyer agrees to reimburse ONICON for such tax or charge or provide ONICON with an acceptable exemption certificate. Payment of invoices will be due 30 days from the date of shipment of the products contained therein. In the event that payment of an invoice is not received by the invoice due date, ONICON will assess a late fee not to exceed 1.5% per month or 18% per year, or the maximum allowable by law whichever is lower.
6. **CANCELLATION:** Buyer may cancel its order, or any part of it, by sending written notice of cancellation to ONICON and paying a reasonable cancellation fee as determined by ONICON. The reasonable cancellation fee will reflect, among other factors, the expenses already incurred and commitments made by ONICON, sales and administrative costs and profit as determined by ONICON. If Buyer received a reduced price based on the quantity of products ordered, but has not purchased the applicable quantity at the time of cancellation, Buyer will pay the price it would have paid had ONICON's sale price been based on the quantity actually purchased.
7. **CHANGES:** If Buyer makes any changes in its drawings, designs, or specifications applicable in any contract with ONICON that cause an increase or decrease in the cost of performance of the contract, or if such changes result in rework or obsolescence, an equitable adjustment shall be made to the contract. Such changes are subject to ONICON's prior written consent.
8. **EXCUSABLE DELAY:** ONICON shall under no circumstance be responsible for failure to fill any order or orders when due to: fires, floods, riots, strikes, freight embargoes or transportation delays, shortage of labor, inability to secure fuel, material supplies, or power at current price or on account of shortages thereof, acts of God or of the public enemy, any existing or future laws or acts of the Federal or State Government (including specifically, but not exclusively, and orders, rules or regulations issued by any official or agency of any such government) affecting the conduct of ONICON's business with which ONICON in its judgment and discretion deems it advisable to comply as a legal or patriotic duty, or due to any cause beyond ONICON's reasonable control.
9. **PATENTS:** ONICON shall defend all suits or proceedings brought against Buyer or its customers arising from claimed infringements of any patent, trademark, service mark or copyright for any product furnished by ONICON and shall indemnify it against all costs, fees, and damages on the condition Buyer promptly notifies ONICON in writing and provides information and assistance to enable ONICON to conduct the defense, provided that ONICON shall have no such obligation in case of infringement resulting from ONICON's conformance to special requirements of Buyer. If ONICON is not able to settle any such suit or proceeding on acceptable terms, ONICON may, at its option, require return of the infringing product and refund the purchase price to Buyer less a reasonable allowance for depreciation or use.
10. **FAIR LABOR STANDARDS ACT:** ONICON represents that all products delivered under this contract are furnished in accordance with the applicable provisions of the Fair Labor Standards Act as amended.
11. **APPLICABLE LAW:** This document and any resulting contract shall be governed by and construed in accordance with the laws of the State of Florida. The courts of the State of Florida and the federal courts located in Florida shall have jurisdiction and venue with respect to litigation to this contract. In the event of litigation, the prevailing party shall be entitled to recover attorney's fees and costs from the non-prevailing party, including appellate attorney's fees.
12. **MODIFICATIONS:** These Conditions of Sale along with the prices, quantities, delivery schedules and other provisions and instructions in applicable quotations by ONICON or Buyer's purchase orders accepted by ONICON shall constitute the entire agreement between ONICON and Buyer pertaining to any resulting contract. They can be modified only in writing.