

**System-10 BTU Meter
Johnson Controls Metasys® N2 Network Interface Installation Guide**



TABLE OF CONTENTS

1.0	INTRODUCTION	5
1.1	PURPOSE OF THIS GUIDE	5
1.2	TYPICAL SYSTEM-10 NETWORK INTERFACE MODULE.....	5
1.3	SPECIFICATIONS	5
1.4	NETWORK SIGNAL CONNECTIONS.....	6
1.4.1	RS485.....	6
1.4.2	Optional Network Interface with Isolated Auxiliary Pulse Input	7
1.5	RS485 BIASING AND TERMINATION.....	10
1.6	NETWORK ADDRESSING.....	10
1.6.1	Changing the Device Address.....	10
2.0	POINT FILE (.ddl).....	12
2.1	.ddl OR POINT INFORMATION	12
2.1.1	Single Mode Point Information	12
2.1.2	Dual or Bi-Directional Mode Point Information	13
2.1.3	Supplementary Tables	14
2.1.4	Sample .ddl Files	17
3.0	NETWORK TROUBLESHOOTING TIPS	19
3.1	TROUBLESHOOTING	19

APPENDIX

A-1	SYSTEM-10 BTU METER COMPUTER BOARD
A-2	SYSTEM-10 BTU METER N2 BOARD
A-3	SYSTEM-10 BTU METER N2 BOARD with Auxiliary Input Pulse

SECTION 1: INTRODUCTION

1.1 PURPOSE OF THIS GUIDE

The purpose of this guide is to provide installation and commissioning procedures and basic installation and operating instructions for the ONICON System-10-N2 serial interface.

1.2 TYPICAL SYSTEM-10 NETWORK INTERFACE MODULE

ONICON's System-10 is a true heat (Btu) computer which accepts data from several sensors, performs a series of computations with that data, and displays and/or transmits the results as an indication of the amount of heat (Btu's) being transferred per unit time or as a totalized amount. It can also be provided with an optional Metasys® N2 serial interface to communicate data to the building control network.

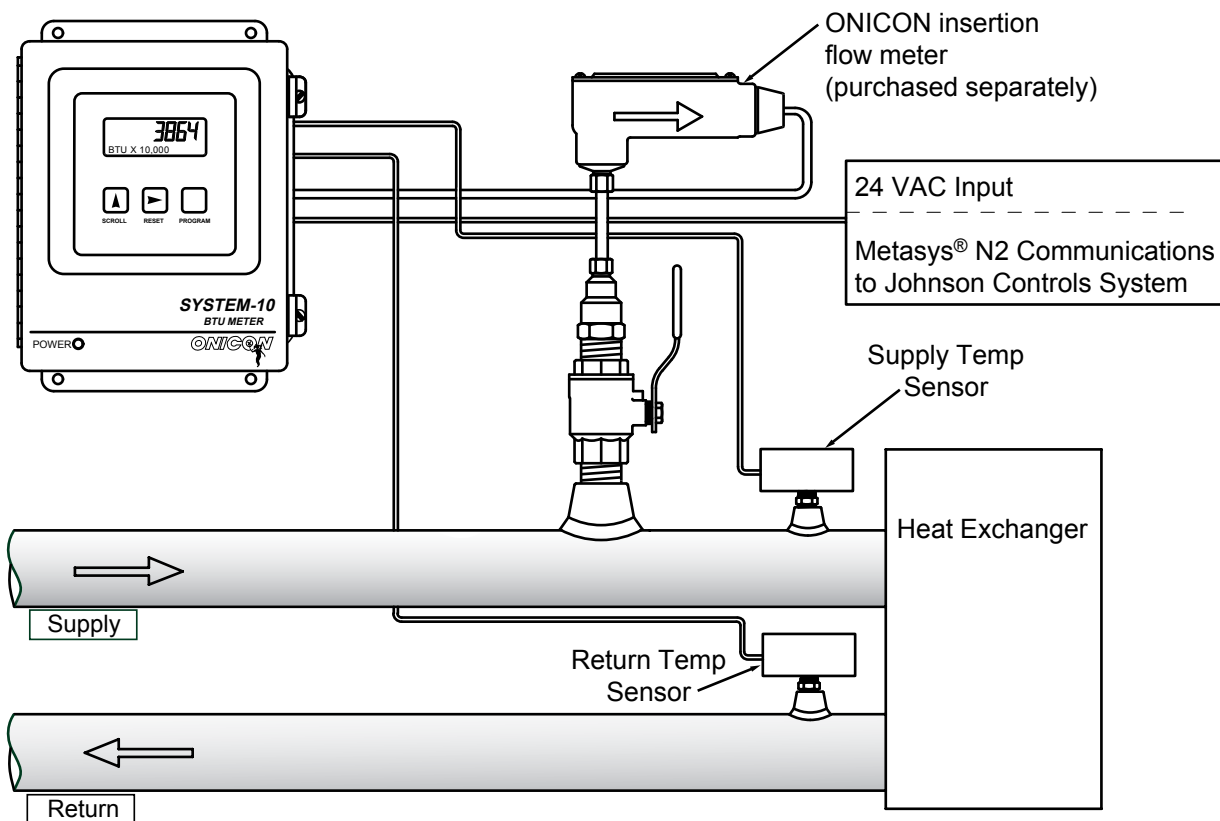

1.3 SPECIFICATIONS

METASYS® N2 NETWORK INTERFACE N2 RS485

Transceiver: 2-wire, half-duplex
Device address range: 1 – 255 (Default: 017)
Baud rate: 9600
Termination: none
Biasing: none

1.4 NETWORK SIGNAL CONNECTIONS

1.4.1 RS485

N2 RS485, 2-wire (half-duplex) serial output connections are connected to terminal as shown. Do not exceed 4.4 in-lb (0.5 Nm) of torque when tightening.



CAUTION

Only qualified service personnel should make connections between the System-10-N2 BTU Meter and the user's external equipment. ONICON assumes no responsibility for damage caused to the external equipment as a result of an improper installation.

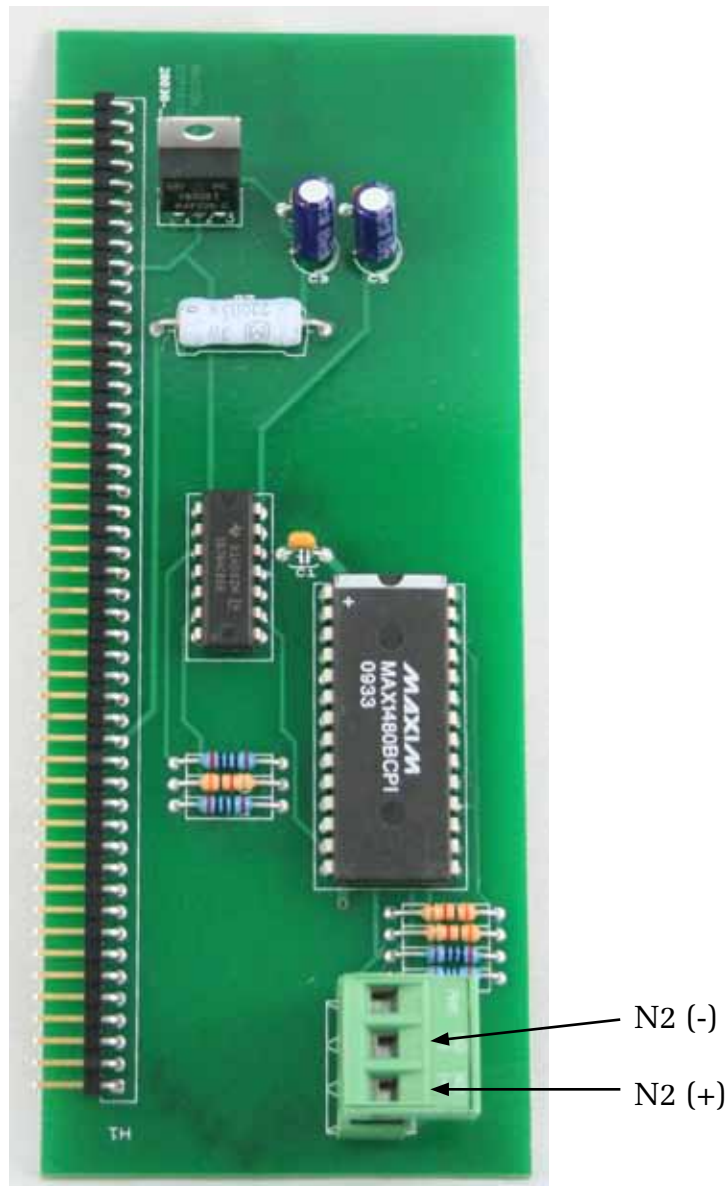

CAUTION

Incoming and outgoing RS485 cable shield wires should be connected together, but must not be connected to the System-10.

1.4.2 Optional Network Interface With Optional Isolated Auxiliary Pulse Input

The System-10 BTU Meter can be provided with an auxiliary input pulse for totalizing pulse outputs from external devices such as water or gas meters. Pulses are accumulated in an internal register, and the totalized value is available on the network. This register can be zeroed via the network.

If the auxiliary pulse input option was ordered at the same time the display was ordered, it will arrive fully configured and ready to use. If it was ordered after the display was delivered and is being installed as a field upgrade, it may be necessary to configure the pulse input. The information is provided below and on the following pages:

The input pulse must meet the following criteria:

1. Frequency input range, 50 Hz maximum
2. 10 millisecond minimum pulse duration

Input Pulse Definition:

In order to configure the communications card for an auxiliary input pulse, you must first determine which type of pulse your meter produces. The allowable types of input pulses are described on the following pages. Based on the type of pulse, set the selector switch (S1) on the communications circuit board (Fig. 1) to the correct setting.

Fig. 1

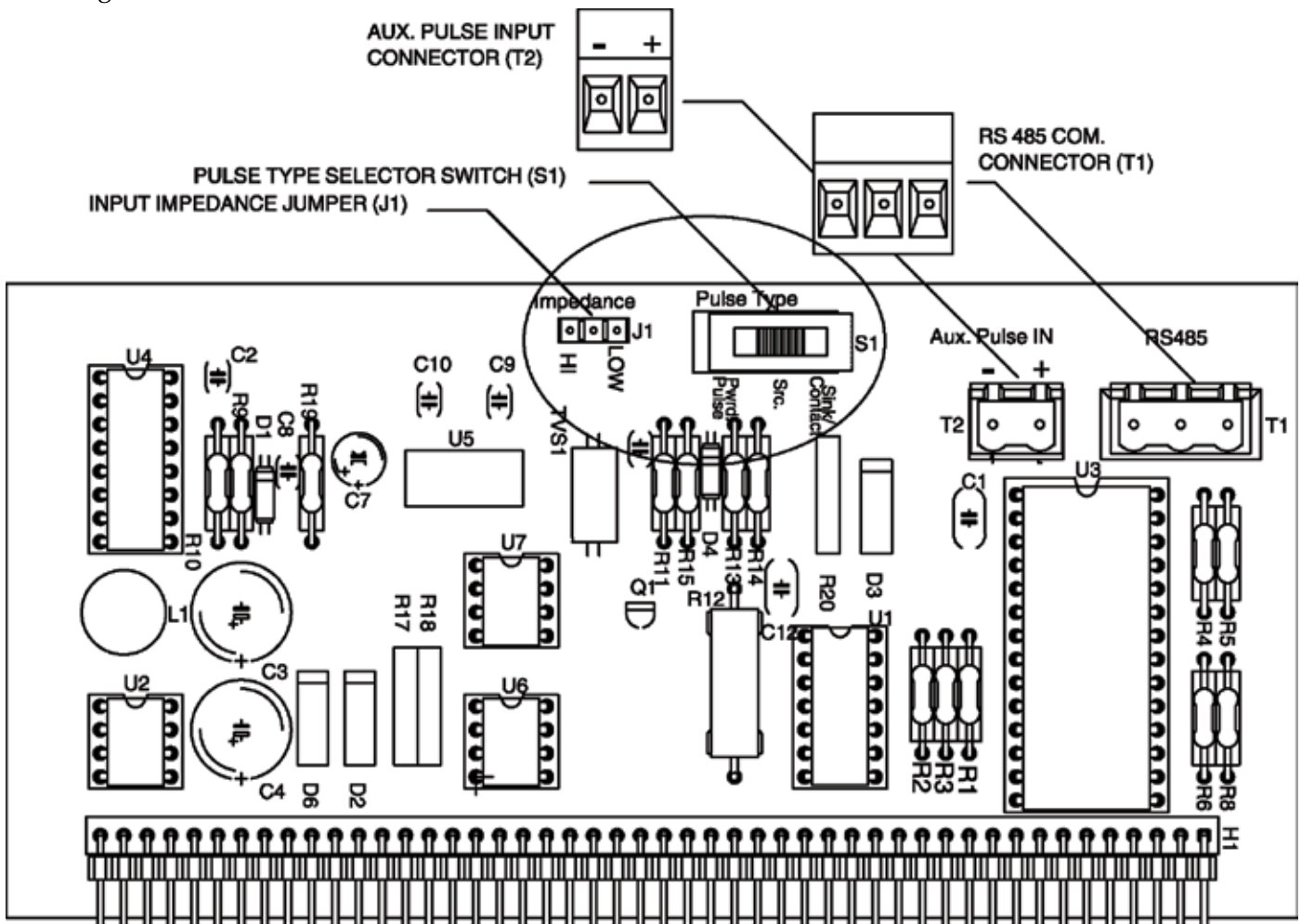

Powered Pulse:

This type of output refers to a pulse which has an associated voltage with it (see Fig. 2). Set the selector switch, S1 to PwrD Pulse. The allowable voltage range is 5-24 VDC. The input impedance is set at the factory to be 11 KOHM via the impedance selector jumper (J1, see Fig. 1). A lower impedance, 3 KOHM can be selected if required by the instrument providing the pulse output. Consult the instrument manufacturer or ONICON if you are uncertain as to the proper jumper selection.

Fig. 2

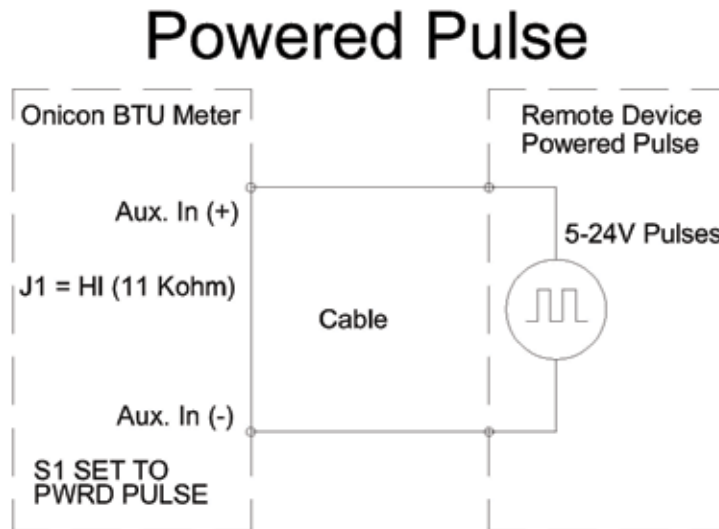

Open Collector (Sourcing):

This type of output refers to an open Collector Switch configured for a sourcing function (see Fig. 3). Set the selector switch, S1 to SRC. The switch must be rated for at least 20mA at 20VDC.

Fig. 3

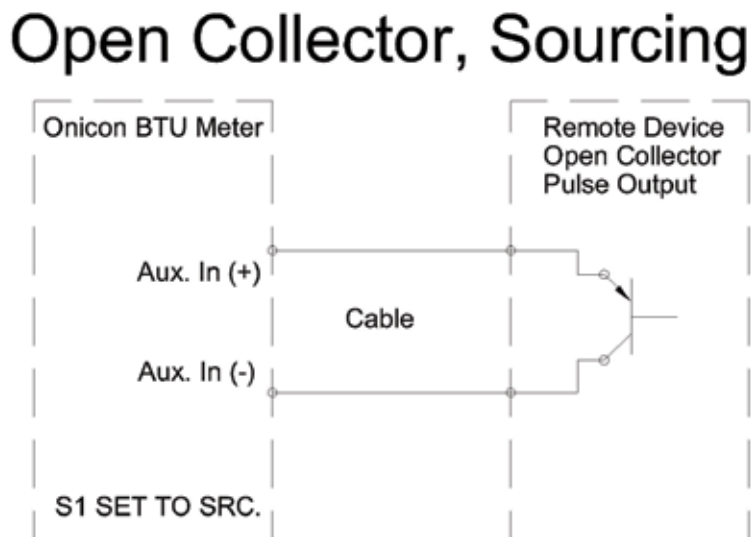

Open Collector Sinking or Dry Contact:

This type of output refers to an open collector switch configured in a current sinking arrangement or a dry contact switch (see Fig. 4 and 5). Set the selector switch, S1 to Sink. In either case, the switch must be rated for at least 20mA at 20 VDC.

Fig. 4

Open Collector, Sinking

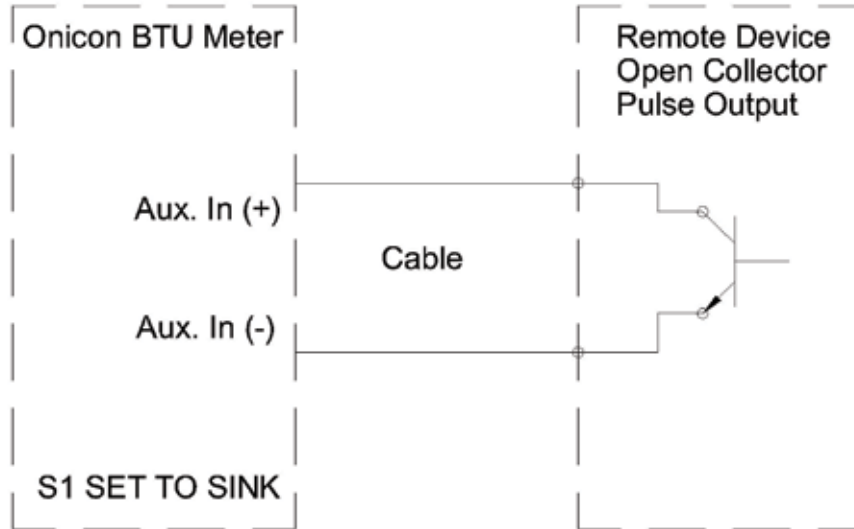
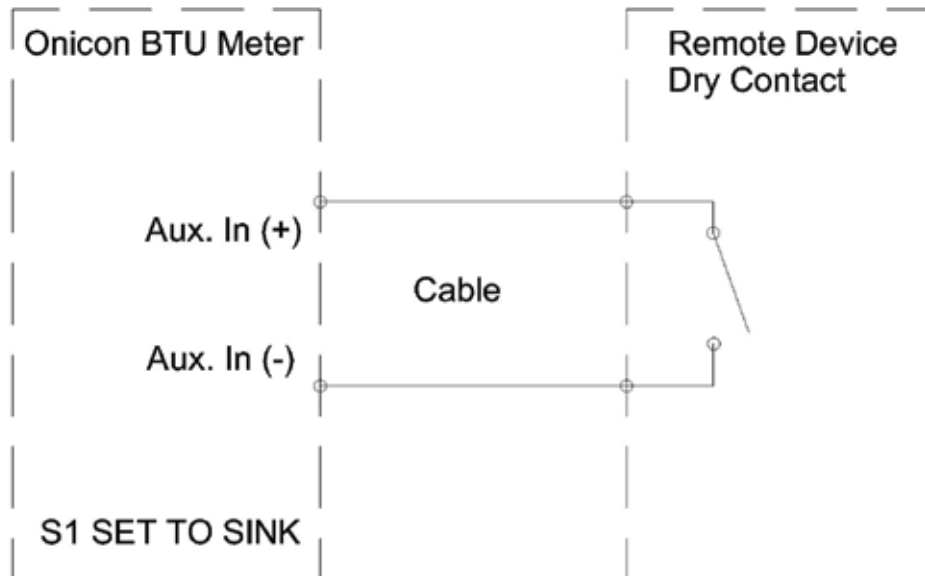

Fig. 5

Contact Closure



1.5 RS485 BIASING AND TERMINATION

The ONICON System-10-N2 does not provide biasing voltage or termination to the RS485 network. A 120Ω termination resistor should be used when the meter is installed at the end of the line.

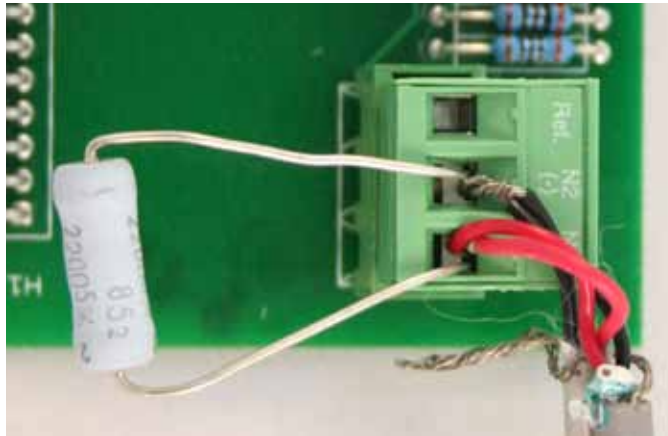

1.6 NETWORK ADDRESSING

Before the System-10 can communicate on the N2 network, the appropriate device address must be programmed into the meter. The N2 network address for ONICON System-10 BTU Meters may be set to any address from 001 to 255. This address is set at the Btu meter. Section 1.6.1 details the procedure for changing this address.

1.6.1 Changing the Device Address

Every ONICON System-10 is individually programmed at the factory with application specific data provided by the customer during the ordering process, and this may include network addressing information. If the device address information was provided, the meter will be programmed with that number. If no address is provided, ONICON Btu meters are programmed with a default address of 017. The address may be changed at the System-10 using the procedure outlined in the table below.

STEP	ACTION	REACTION	COMMENT
0	Obtain a device address from the network administrator.		The device address is a three digit number between 001 - 255, excluding zero.
1	With the meter running, open the front panel and locate switch DEV ADD/PROG ENAB. Press DEV ADD/PROG ENAB and then release it.	None	The DEV ADD/PROG ENAB is located on the heat computer board. (See appendix page A-1.)
2	Close the front panel.		
3	Press the PROGRAM button. (If you do not press the PROGRAM button, the meter will revert to the RUN mode after 5 minutes.)	The System-10 changes to PROGRAM mode and the DEVICE ID page will appear with the first digit of the address flashing.	The PROGRAM button is on the front panel.

STEP	ACTION	REACTION	COMMENT
4	Successively press the SCROLL button to increment the number to the desired value from 0-9.	The number increments by one each time you press the button.	The SCROLL button is on the front panel.
5	Press the RESET button.	The second character blinks.	The RESET button is on the front panel.
6	Successively press the SCROLL button to increment the number to the desired value from 0-9.	The number increments by one each time you press the button.	The SCROLL button is on the front panel.
7	Press the RESET button.	The third character blinks.	The RESET button is on the front panel.
8	Successively press the SCROLL button to increment the number to the desired value from 0-9.	The number increments by one each time you press the button.	The SCROLL button is on the front panel.
9	Once the correct value has been entered, press PROGRAM.	The FRONT PANEL RESET page appears.	It is not necessary to change anything on this page.
10	Press the PROGRAM button.	The SAVE CHANGES page appears.	The new device address must be saved to take effect.
11	Press the SCROLL button.	The N changes to Y on the SAVE CHANGES page.	The Y must be selected in order for the new address to take effect.
12	Press the PROGRAM button.	The new address is saved and the display reverts to the RUN mode.	
13	Open the front panel and locate the RESET switch. Press to reset the System-10.	When polled, the System-10 will automatically begin to communicate with the network.	RESET is located along the top of the heat computer board. (See appendix page A-1.)

SECTION 2.0: POINT FILE (.ddl)

2.1 ddl OR POINT FILE

The System-10 BTU Meter operates in one of three operating modes: single, dual or bi-directional. The dual and bi-directional modes utilize the same .ddl files. The tables below contain point information for each of the operating modes.

The .ddl file contains the information that identifies the device to the N2 supervisory controller. It also specifies the variables that are available to be transmitted to and from the device on the network.

The tables below contains .ddl file information

2.1.1 Single Mode Point Information

In single mode operation, only one register accumulates energy and one register accumulates volume.

NPT ₁	NPA ₂	UNITS	POINT DESCRIPTION	RANGE/VALUE
AI	1	Selectable (See Energy Rate Table)	Energy Rate	0 - 999,999
AI	2	Selectable (See Volume Rate Table)	Volume Rate	0 - 999,999
AI	3	Deg F	Supply Temperature	0.0 Deg F - 500.0 Deg F
AI	4	Deg F	Return Temperature	0.0 Deg F - 500.0 Deg F
BI	1	None	Dual Mode Status Indicator - Heating (supply > return) - Cooling (supply < return) OR - Forward flow - Reverse flow (Refer to Section 3.3.3 of System-10 manual for flow direction information.)	0 - Heating 1 - Cooling 0 - Forward 1 - Reverse
ADF	1	Selectable (See Energy Total Table)	Mode 1 Energy Total	0 – 999,999
ADF	2	Selectable (See Volume Total Table)	Mode 1 Volume Total	0 – 999,999
ADF	5	User Defined	Auxiliary Pulse Input Sum	0 – 999,999
BO	1	None	Reset (Zero) Energy Total, ADF-1	OVERRIDE Binary Output, Object 1 - ON

NPT ₁	NPA ₂	UNITS	POINT DESCRIPTION	RANGE/VALUE
BO	2	None	Reset (Zero) Volume Total, ADF-2	OVERRIDE Binary Output, Object 2 - ON
BO	5	None	Rest (Zero) Auxiliary Pulse Sum	OVERRIDE Binary Output, Object 5 - ON
Note 1: Network Point Type Note 2: Network Point Address				

2.1.2 Dual or Bi-Directional Mode Point Information

In either dual or bi-directional operation, two registers are available for the accumulation of energy and two are available for the accumulation of volume. Thus, four ADF points are required. Four binary output points are required to zero the four ADF energy and volume accumulation registers.

NPT ₁	NPA ₂	UNITS	POINT DESCRIPTION	RANGE / VALUE
AI	1	Selectable (See Energy Rate Table)	Energy Rate	0 – 999,999
AI	2	Selectable (See Volume Rate Table)	Volume Rate	0 – 999,999
AI	3	Deg F	Supply Temperature	0.0 Deg F – 250.0 Deg F
AI	4	Deg F	Return Temperature	0.0 Deg F – 250.0 Deg F
BI	1	None	Heating – Cooling Indicator	0 – Heating; 1 - Cooling
ADF	1	Selectable (See Energy Total Table)	Mode 1 Energy Total	0 – 999,999
ADF	2	Selectable (See Volume Total Table)	Mode 1 Volume Total	0 – 999,999
ADF	3	Selectable (See Energy Total Table)	Mode 2 Energy Total	0 – 999,999
ADF	4	Selectable (See Volume Total Table)	Mode 2 Volume Total	0 – 999,999
ADF	5	User Defined	Auxiliary Pulse Input Sum	0 – 999,999
BO	1	None	Reset Mode 1 Energy Total	OVERRIDE Binary Output, Object 1 - ON
BO	2	None	Reset Mode 1 Volume Total	OVERRIDE Binary Output, Object 2 - ON
BO	3	None	Reset Mode 2 Energy Total	OVERRIDE Binary Output, Object 3 - ON

NPT ₁	NPA ₂	UNITS	POINT DESCRIPTION	RANGE / VALUE
BO	4	None	Reset Mode 2 Volume Total	OVERRIDE Binary Output, Object 4 - ON
BO	5	None	Reset (Zero) Auxiliary Pulse Sum	OVERRIDE Binary Output, Object 5 - ON
Note 1: Network Point Type Note 2: Network Point Address				

2.1.3 Supplementary Tables

The following tables illustrate the setting of unit descriptions in the .ddl file.

ENERGY RATE		
LCD DISPLAY UNITS	LCD DISPLAY MULTIPLIER	POINT FILE UNIT DESCRIPTION
BTU / HR	1	BTU / H
	10	10BTU / H
	100	100BTU / H
	1,000	KBTU / H
	10,000	10KBTU / H
	100,000	100KBTU / H
	1,000,000	MEGBTU / H
TONS	1	TONS
	10	10TONS
	100	100TONS
KW	1	KW
	10	10KW
	100	100KW
	1,000	KKW
VOLUME RATE		
LCD DISPLAY UNITS	LCD DISPLAY MULTIPLIER	POINT FILE UNIT DESCRIPTION
L / S (LITERS / SECOND)	1	L / S
	10	10L / S

L / M (LITERS / MINUTE)	1	L / M
	10	10L / M
	100	100L / M
	1,000	KL / M
	10,000	10KL / M
	100,000	100KL / M
	1,000,000	MEGKL / M
L / H (LITERS / HOUR)	1	L / H
	10	10L / H
	100	100L / H
	1,000	KL / H
	10,000	10KL / H
	100,000	100KL / H
	1,000,000	MEGKL / H
M ³ H (METERS CUBED / HOUR)	1	M ³ H
	10	10M ³ H
GPM (GALLONS / MINUTE)	1	GPM
	10	10GPM
GPH (GALLONS / HOUR)	1	GPH
	10	10GPH
	100	100GPH
	1,000	KGPH
	10,000	10KGPH
	100,000	100KGPH
	1,000,000	MEGGPH
MGD (MILLION GALLONS / DAY)	1	MGD
	10	10MGC

ENERGY TOTAL		
BTU (BRITISH THERMAL UNIT)	1	BTU
	10	10BTU
	100	100BTU
	1,000	KBTU
	10,000	10KBTU
	100,000	100KBTU
	1,000,000	MEGBTU
ENERGY TOTAL		
TNHR (TON-HOUR)	1	TONH
	10	10TONH
	100	100TONH
	1,000	KTONH
ENERGY TOTAL		
KWHR (KILOWATT-HOUR)	1	KWHR
	10	10KWHR
	100	100KWHR
	1,000	KKWHR
VOLUME TOTAL		
LCD DISPLAY UNITS	LCD DISPLAY MULTIPLIER	POINT FILE UNIT DESCRIPTION
LTRS (LITERS)	1	LTRS
	10	10LTRS
	100	100LTRS
	1,000	KLTRS
	10,000	10KLTRS
	100,000	100KLTRS
VOLUME TOTAL		
M ³ (CUBIC METERS)	1	M ³
	10	10M ³
	100	100M ³
	1,000	KM ³
VOLUME TOTAL		
GAL (GALLONS)	1	GAL
	10	10GAL
	100	100GAL
	1,000	KGAL
	10,000	10KGAL
	100,000	100KGAL

2.1.4 SAMPLE .ddl FILES

Single Mode Meter .ddl File

```
SAMPLE SINGLE MODE .ddl FILE
*****
* ONICON, SYSTEM-10 BTU Meter: SERIAL NUMBER: XXXX
* PROGRAM VERSION: X.X
* Metasys-N2 Address: xxxx
* Single Mode
* This .ddl file is device specific to the above serial number.
*.This data is valid at the time of creation (07/23/2004 1:00 pm)
* And can be rendered invalid due to field changes in units
* or multipliers.
*
@MODEL+
CSMODEL "ONICON", "VND"
*
AITITLE "Analog Inputs"
BITITLE "Binary Inputs"
ADTTITLE "Analog Data Points"
BOTITLE "Binary Outputs"
*
ANALOG INPUTS COS AVAILABLE.
CSAI "AI1",N,N,"ENRATE", "10KBTU/HR"
CSAI "AI2",N,N,"VORATE", "10GPM"
CSAI "AI3",N,N,"TMPSPPLY", "DEGF"
CSAI "AI4",N,N,"TMPRTN", "DEGF"
*
* BINARY INPUT COS AVAILABLE.
CSBI "BI1",Y,Y, "MODEIND", "N/A"
*
* N2 READS ADF1, ADF2 FOR ENERGY AND VOLUME TOTALS.
CSAD "ADF1",N,N,"ENERTOT", "10KBTU"
CSAD "ADF2",N,N,"VOLMTOT", "10GAL"
CSAD "ADF5",N,N,"CNTSTOT", "PLSSUM"
*
* NEVER MAP OUTPUT POINTS IN A CS MODEL AS DISCRETE OBJECTS.
* RESET VOLUME AND ENERGY TOTALS WITH COMMAND OVERRIDE BO ON
CSBO "BO1",Y,Y, "RSTENTOT", "N/A", "reset"
CSBO "BO2",Y,Y, "RSTVLTOT", "N/A", "reset"
CSBO "BO5",Y,Y, "RSTXTOT", "N/A", "reset"
*****END SINGLE MODE DDLFILE*****
```

Dual Mode Meter .ddl File

SAMPLE DUAL MODE .ddl FILE

* ONICON, SYSTEM-10 BTU Meter: SERIAL NUMBER: XXXX

* PROGRAM VERSION: X.X

* Metasys-N2 Address: xxxx

* Dual or Bidirectional Mode

* This .ddl file is device specific to the above serial number.

* This data is valid at the time of creation (07/23/2004 1:00 pm)

* And can be rendered invalid due to field changes in units

* or multipliers.

*

@MODEL+

CSMODEL "ONICON", "VND"

*

AITITLE "Analog Inputs"

BITITLE "Binary Inputs"

ADTITLE "Analog Data Points"

BOTITLE "Binary Outputs"

*

ANALOG INPUTS COS AVAILABLE.

CSAI "AI1",N,N,"ENRATE", "10KBTU/HR"

CSAI "AI2",N,N,"VORATE", "10GPM"

CSAI "AI3",N,N,"TMPSPLY", "DEGF"

CSAI "AI4",N,N,"TMPRTN", "DEGF"

*

* BINARY INPUT COS AVAILABLE.

CSBI "BI1",Y,Y, "MODEIND", "N/A"

*

* N2 READS ADF1, - ADF4, FOR M-1, M-2 ENERGY AND VOLUME TOTALS.

CSAD "ADF1",N,N,"M1ENTOT", "10KBTU"

CSAD "ADF2",N,N,"M1VOTOT", "10GAL"

CSAD "ADF3",N,N,"M2ENTOT", "10KBTU"

CSAD "ADF4",N,N,"M2VOTOT", "10GAL"

*

* NEVER MAP OUTPUT POINTS IN A CS MODEL AS DISCRETE OBJECTS.

* RESET VOLUME AND ENERGY TOTALS WITH COMMAND OVERRIDE BO TO ON

CSBO "BO1",Y,Y, "RSTM1EN", "N/A", "reset"

CSBO "BO2",Y,Y, "RSTM1VL", "N/A", "reset"

CSBO "BO3",Y,Y, "RSTM2EN", "N/A", "reset"

CSBO "BO4",Y,Y, "RSTM2VL", "N/A", "reset"

*

*****END DUAL MODE DDL FILE *****

SECTION 3: NETWORK TROUBLESHOOTING TIPS

3.1 TROUBLESHOOTING

Reported Problem	Possible Solutions
<p>Device will not communicate with the network controller.</p>	<ul style="list-style-type: none">• A unique address is required for each device on the network. Duplicate addresses will cause some or all of the devices on the network to quit working. (See section 1.6.1 of this manual for details.)• The RS485 network cable connections are polarity sensitive and must be connected the same way on every device. (i.e. + to + and - to -). (See section 1.4.1 of this manual for details.)• Shield drain connections should be daisy chained in the same manner as the signal cables for RS485. The shield drain wire should be left unterminated at the end of the cable and connected to earth only at the supervisory controller. Shield wires must not be connected to the RS485 connector on the System-10.• The maximum number of devices allowed on a RS485 network segment without a repeater is 32. Adding more than 32 devices to a single segment may reduce the transceiver output voltage to a level that is too low to be distinguished from background noise on the cable.• RS485 cable impedance should be matched to a termination resistor at the end of the cable. ONICON boards do not have a resistor for termination. A resistor should only be used if the display is the last device on the network cable. (See section 1.5.1 of this manual for details.)

Reported Problem	Possible Solutions
<p>Network communications are disrupted when the device is connected.</p>	<ul style="list-style-type: none"> • The RS485 network cable connections are polarity sensitive and must be connected the same way on every device. (i.e. + to + and - to -). (See section 1.4.1 of this manual for details.) • A unique address is required for each device on the network. Duplicate addresses will cause some or all of the devices on the network to quit working. (See section 1.6.1 of this manual for details.) • Shield drain connections should be daisy chained in the same manner as the signal cables for RS485. The shield drain wire should be left unterminated at the end of the cable and connected to earth only at the network master controller. Shield wires must not be connected to the RS485 connector on the System-10.

APPENDIX

A-1 SYSTEM-10 BTU METER COMPUTER BOARD

A-2 SYSTEM-10 BTU METER N2 BOARD

A-3 SYSTEM-10 BTU METER N2 BOARD with Auxiliary Input Pulse

SYSTEM-10 BTU METER COMPUTER BOARD

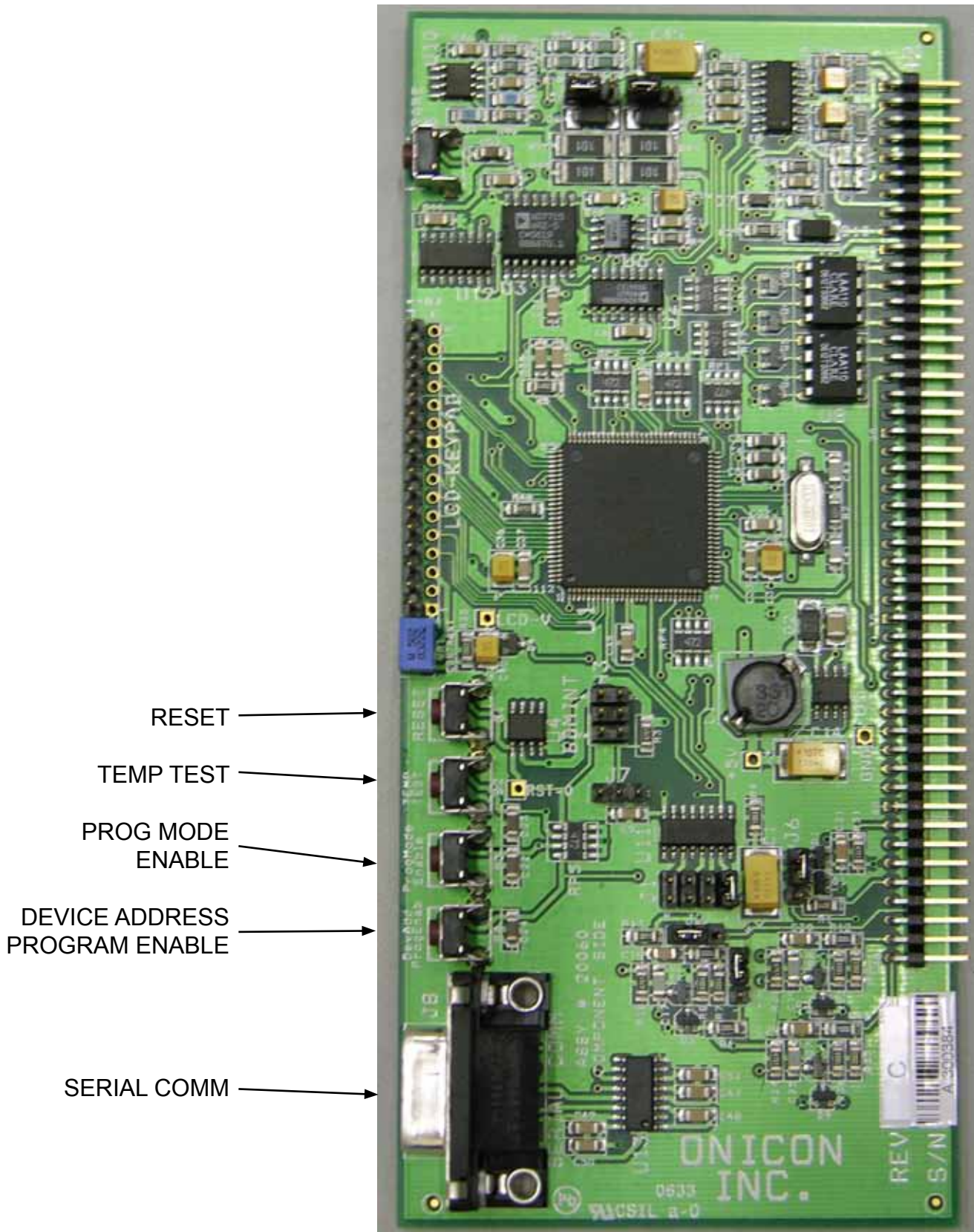

RESET →

TEMP TEST →

PROG MODE
ENABLE →

DEVICE ADDRESS
PROGRAM ENABLE →

SERIAL COMM →

SYSTEM-10 BTU METER N2 BOARD

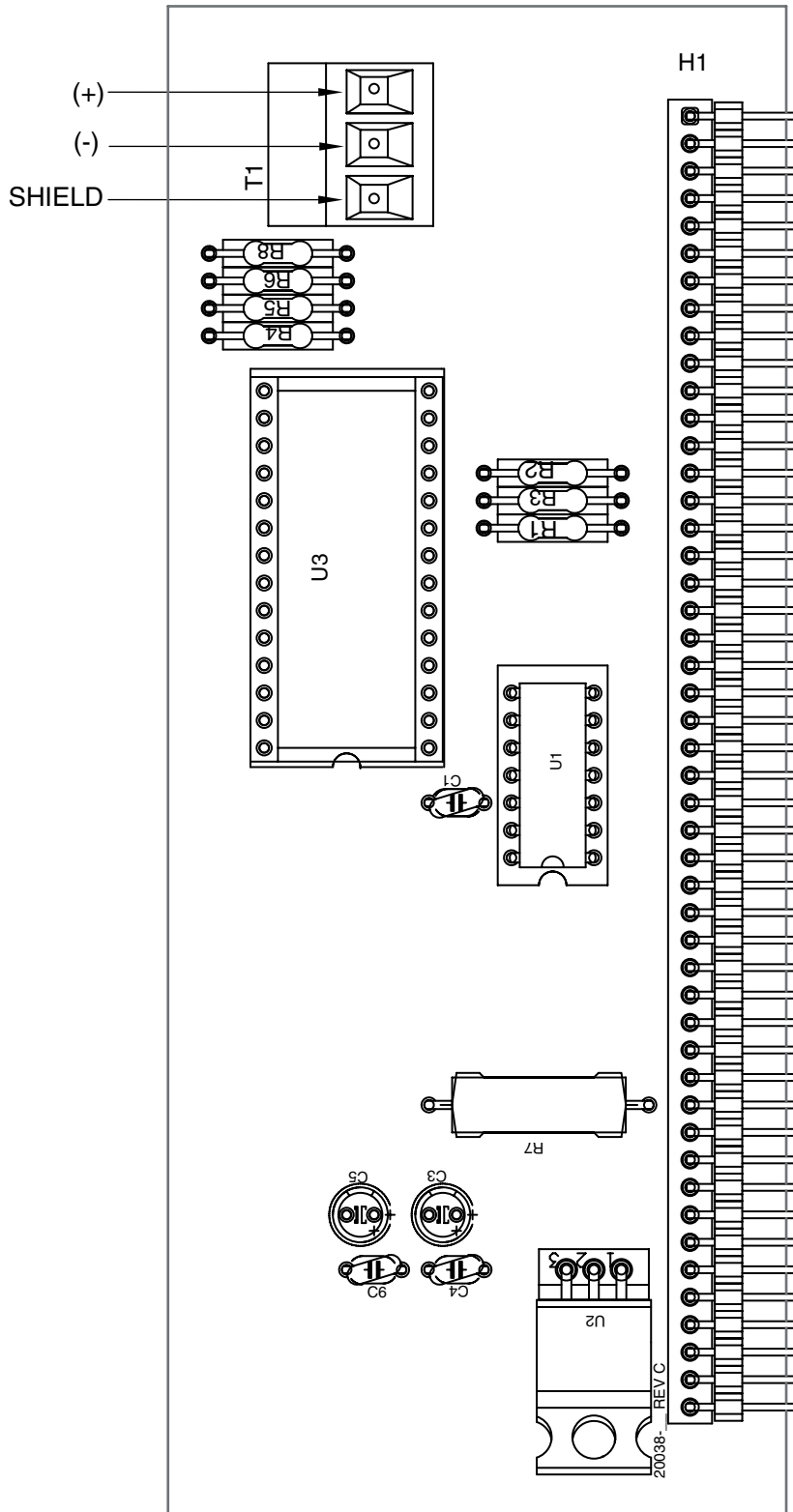

SYSTEM-10 BTU METER N2 BOARD with Auxiliary Input Pulse

